

# Model Name: P215HAN02.0

Issue Date : 2017/03/30

- (\*) Preliminary Specifications
- ( ) Final Specifications

Customer Signature	Date	AUO	Date
Approved By		Approval By PM Director	
<hr/>		Jacky Su	<hr/>
Note		Reviewed By RD Director	
		Eugene CC Chen	<hr/>
		Reviewed By Project Leader	
		Jerry Lin	<hr/>
		Prepared By PM	
		Lorenz Shiau	<hr/>

## Contents

<b>1. General Description</b> .....	5
1.1. Display Characteristics.....	5
1.2. Optical Characteristics.....	6
1.3. Mechanical Characteristics.....	11
1.3.1. Placement Suggestions.....	11
1.3.2. Mechanical Characteristics.....	12
1.3.3. Absolute Maximum Ratings.....	13
<b>2. Electrical Specification</b> .....	14
2.1. Block Diagram.....	14
2.2. Interface Connection.....	15
2.2.1. Connector Type.....	15
2.2.2. Connector Pin Assignment.....	15
2.3. Electrical Characteristics.....	17
2.3.1. Absolute Maximum Rating.....	17
2.3.2. Recommended Operating Condition.....	17
2.4. Signal Characteristics.....	19
2.4.1. LCD Pixel Format.....	19
2.4.2. LVDS Data Format.....	19
2.4.3. Color versus Input Data.....	20
2.4.4. LVDS Specification.....	20
2.4.5. Input Timing Specification.....	23
2.4.6. Input Timing Diagram.....	24
2.5. Power ON/OFF Sequence.....	25
<b>3. Backlight Unit</b> .....	26
3.1. Block Diagram.....	26
3.2. Interface Connection.....	27
3.2.1. Connector Type.....	27
3.2.2. Connector Pin Assignment.....	28
3.3. Electrical Characteristics.....	29
3.3.1. Absolute Maximum Rating.....	29
3.3.2. Recommended Operating Condition.....	29
<b>4. Reliability Test Items</b> .....	31
<b>5. International Standard</b> .....	32
5.1. Safety.....	32
5.2. EMC.....	32
<b>6. Packing</b> .....	33
6.1. Definition of Label.....	33
6.2. Packing Methods.....	34

<b>7. Precautions</b> .....	36
7. Precautions .....	36
7.1. Mounting Precautions .....	36
7.2. Operating Precautions .....	36
7.3. Operating Condition for Public Information Display .....	37
7.4. Electrostatic Discharge Control .....	37
7.5. Precautions for Strong Light Exposure .....	38
7.6. Storage .....	38
7.7. Handling Precautions for Protection Film .....	38

AUO confidential for Symmetron only



# 1. General Description

This specification applies to the 21.5 inch wide Color a-Si TFT-LCD Module P215HAN02.0. The display supports the Full HD - 1920(H) x 1080(V) screen format and 16.7M colors (8 bits RGB data input). The input interface is Dual channel LVDS and this module doesn't contain a driver board for backlights.

## \* General Information

### 1.1. Display Characteristics

The following items are characteristics summary on the table under 25°C condition:

ITEMS	Unit	SPECIFICATIONS
Screen Diagonal	[mm]	546.86 (21.5")
Active Area	[mm]	476.064 (H) x 267.786 (V)
Pixels H x V	-	1920(x3) x 1080
Pixel Pitch	[um]	247.95 (per one triad) x247.95
Pixel Arrangement	-	R.G.B. Vertical Stripe
Display Mode	-	AHVA, normally Black
White Luminance ( Center )	[cd/m2]	1500 (Typ.)
Contrast Ratio	-	1000 (Typ.)
Response Time	[msec]	25 (Typ., G/G)
Power Consumption (LCD Module + Backligh unit)	[Watt]	<b>38.1</b> (Typ.) LCD module : PDD (Typ.)= 2.3 @ White pattern,Fv=60Hz Backlight unit : P <sub>BLU</sub> (Typ.) = <b>35.8</b> @Is= 47 mA
Weight	[Grams]	<b>2.1 Kg</b>
Outline Dimension	[mm]	501.1(H) x 292.2(V) x16.3 (D) Typ
Electrical Interface	-	Dual channel LVDS , 8-bit RGB data input
Support Color	-	16.7M colors
Surface Treatment	-	Anti-Glare, 3H
Temperature Range		
Operating	[°C]	0 to +50
Storage (Shipping)	[°C]	-20 to +60
RoHS Compliance	-	RoHS Compliance

## 1.2. Optical Characteristics

The optical characteristics are measured on the following test condition.

Test Condition:

1. Equipment setup: Please refer to Note 1-1.
2. Panel Lighting time: 30 minutes
3. VDD=5.0V, Fv=60Hz, Is=55mA, Ta=25°C

Symbol	Description		Min.	Typ.	Max.	Unit	Remark
Lw	White Luminance (Center of screen)		1200	1500	-	[cd/m <sup>2</sup> ]	Note 1-1 By SR-3
Luni	Luminance Uniformity (9 points)		75	80	-	[%]	Note 1-2 By SR-3
CR	Contrast Ratio (Center of screen)		600	1000	-	-	Note 1-3 By SR-3
θR	Horizontal Viewing Angle (CR=10)	Right	75	89	-	[degree]	Note 1-4 By SR-3
θL		Left	75	89	-		
ΦH	Vertical Viewing Angle (CR=10)	Up	75	89	-		
ΦL		Down	75	89	-		
θR	Horizontal Viewing Angle (CR=5)	Right	75	89	-		
θL		Left	75	89	-		
ΦH	Vertical Viewing Angle (CR=5)	Up	75	89	-		
ΦL		Down	75	89	-		
T <sub>GTG</sub>	Response Time	Gray to Gray	-	25	-	[msec]	Note 1-5 By TRD-100
Rx	Color Coordinates (CIE 1931)	Red x	TBD	TBD	TBD	-	By SR-3
Ry		Red y	TBD	TBD	TBD		
Gx		Green x	TBD	TBD	TBD		
Gy		Green y	TBD	TBD	TBD		
Bx		Blue x	TBD	TBD	TBD		
By		Blue y	TBD	TBD	TBD		
Wx		White x	0.283	0.313	0.343		
Wy		White y	0.299	0.329	0.359		
NTSC Area Ratio				72		[%]	By SR-3
CT	Crosstalk		-	-	1.5	[%]	Note 1-6 By SR-3

**Note 1-1:** Equipment setup :

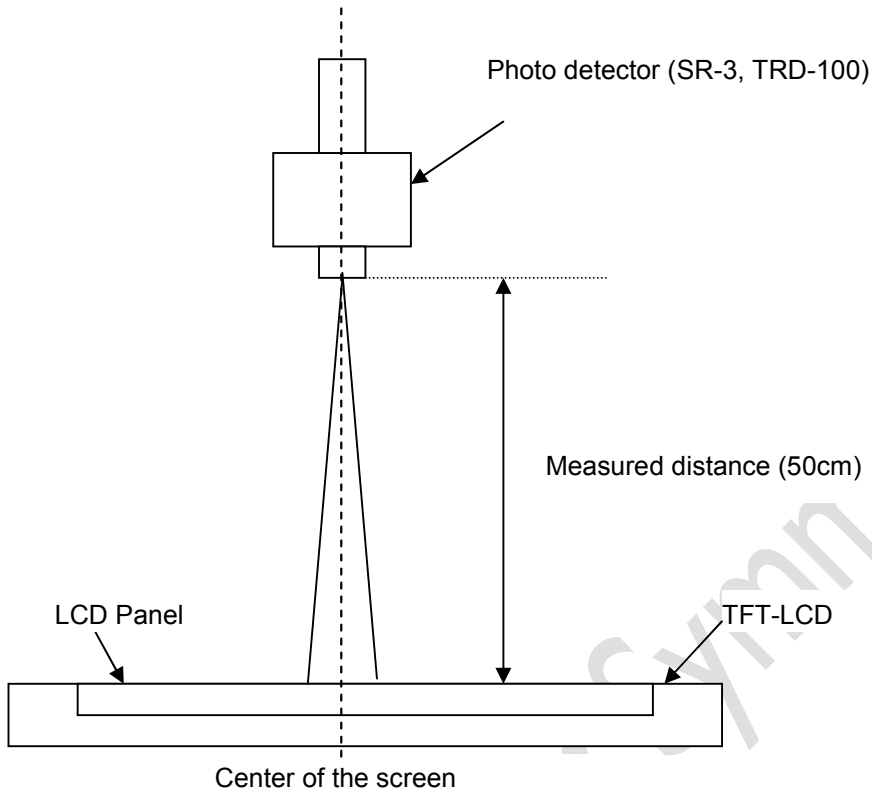

**Note 1-2:** Luminance Uniformity Measurement

**Definition:**

$$\text{Luminance Uniformity} = \frac{\text{Minimum Luminance of 9 Points (P1 ~ P9)}}{\text{Maximum Luminance of 9 Points (P1 ~ P9)}}$$

a. Test pattern: White Pattern

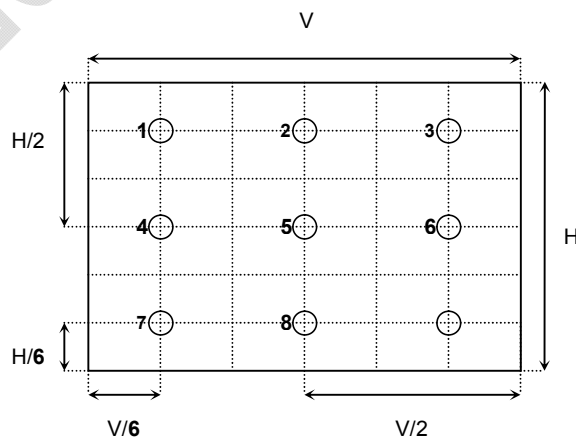

**Note 1-3: Contrast Ratio Measurement**

**Definition:**

$$\text{Contrast Ratio} = \frac{\text{Luminance of White pattern}}{\text{Luminance of Black pattern}}$$

- a. Measured position: Center of screen (P5) & perpendicular to the screen ( $\theta = \Phi = 0^\circ$ )

**Note 1-4: Viewing angle measurement**

**Definition:** The angle at which the contrast ratio is greater than 10 & 5 .

- a. Horizontal view angle: Divide to left & right ( $\theta_L$  &  $\theta_R$ )

Vertical view angle: Divide to up & down ( $\Phi_H$  &  $\Phi_L$ )

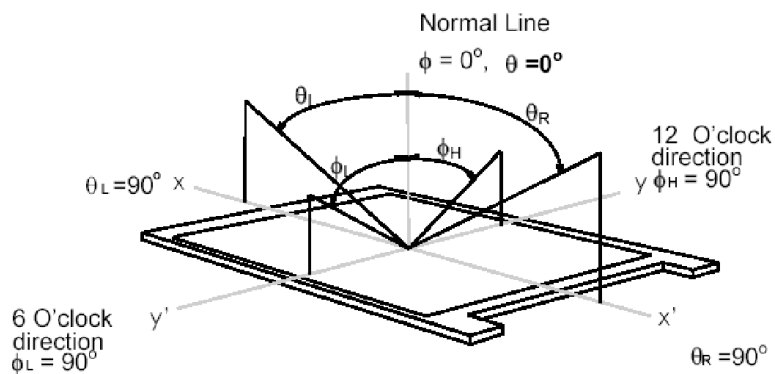

**Note 1-5: Response time measurement**

The output signals of photo detector are measured when the input signals are changed from “Gray level A” to “Gray level B” (falling time,  $T_f$ ), and from “Gray level B” to “Gray level A” (rising time,  $T_r$ ), respectively. The response time is interval between the 10% and 90% of optical response.

The gray to gray response time is defined as the following table.

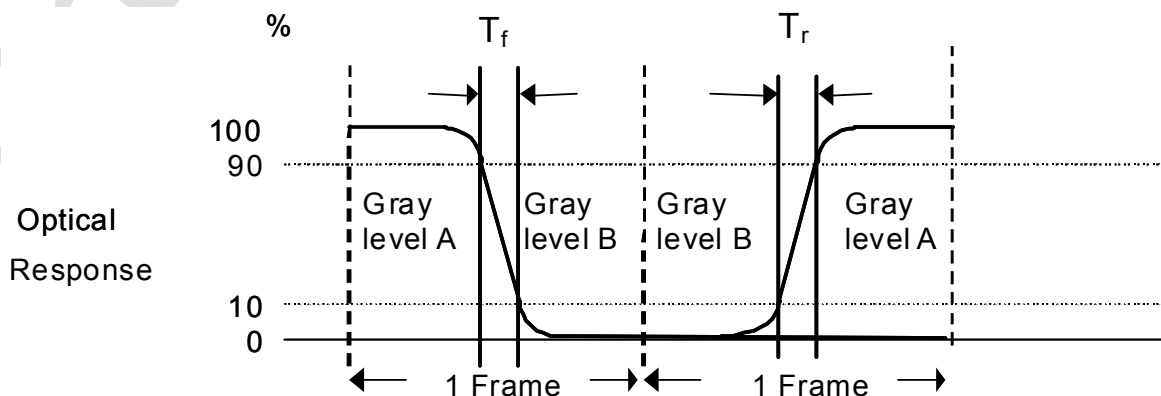



Gray Level to Gray Level		Target gray level				
		L0	L63	L127	L191	L255
Start gray level	L0					
	L63					
	L127					
	L191					
	L255					

■  $T_{GTG\_typ}$  is the total average time at rising time and falling time of gray to gray.

**Note 1-6:** Crosstalk measurement

**Definition:**

CT = Max. (CTH,CTV);

Where

a. Maximum Horizontal Crosstalk :

$$CTH = \text{Max.} (|Y_{BL} - Y_{AL}| / Y_{AL} \times 100 \%, |Y_{BR} - Y_{AR}| / Y_{AR} \times 100 \%);$$

Maximum Vertical Crosstalk:

$$CTV = \text{Max.} (|Y_{BU} - Y_{AU}| / Y_{AU} \times 100 \%, |Y_{BD} - Y_{AD}| / Y_{AD} \times 100 \%);$$

b.  $Y_{AU}, Y_{AD}, Y_{AL}, Y_{AR}$  = Luminance of measured location without Black pattern

$Y_{BU}, Y_{BD}, Y_{BL}, Y_{BR}$  = Luminance of measured location with Black pattern

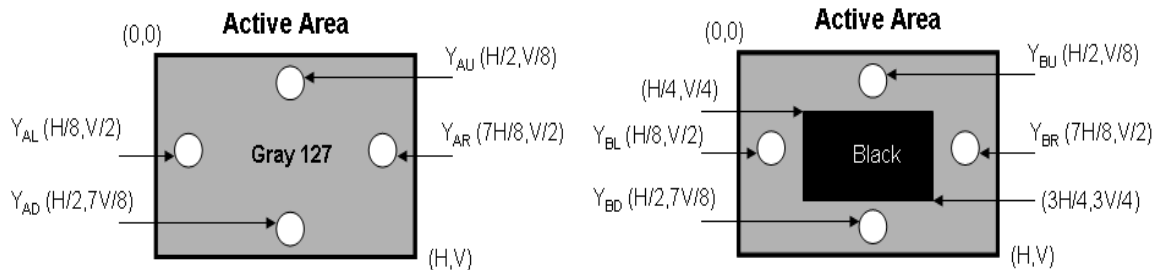

**Note 1-7: Flicker measurement**

a. Test pattern: It is listed as following.

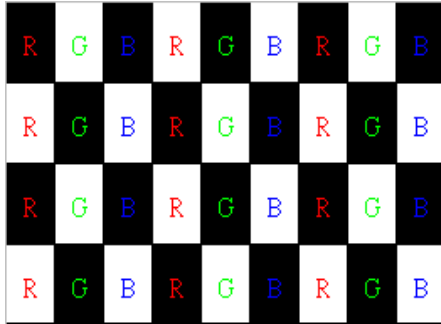

Gray level = L0

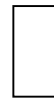

Gray level = L127

R: Red, G: Green, B: Blue

b. Measured position: Center of screen (P5) & perpendicular to the screen ( $\theta=\Phi=0^\circ$ )

**1.3. Mechanical Characteristics**

The contents provide general mechanical characteristics for the model P215HAN02.0 In addition the figures in the next page are detailed mechanical drawing of the LCD.

Item	Dimension	Unit	Note
Outline Dimension	Horizontal	501.1	mm
	Vertical	292.2	mm
	Depth (typ)	16.3	mm
Weight	<b>2100</b>	G	

**1.3.1. Placement Suggestions**

1. Landscape Mode: The default placement is T-Con Side on the lower side and the image is shown upright via viewing from the front.
2. Portrait Mode: The default placement is that T-Con side has to be placed on the left side via viewing from the front.

Landscape (Front view)

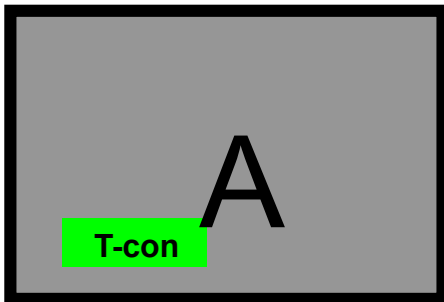

Portrait (Front view)

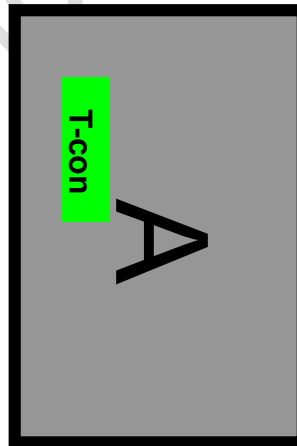

**1.3.2. Mechanical Characteristics**

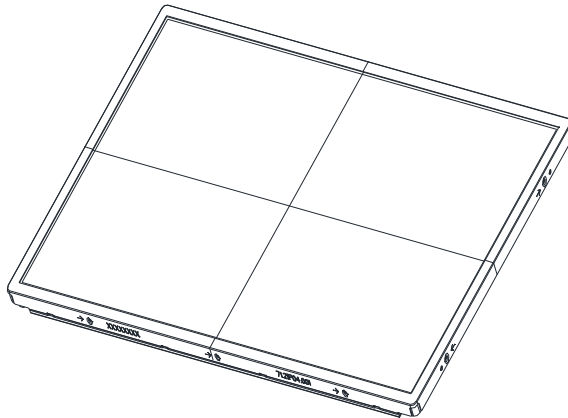

ITEM	QTY	PART NAME	MATERIAL	PART NO.
1	1	59_BLU-ASM_P215HAN02-0	-	xxx-xxxx-xxx
2	1	9I_CELL-ASM_P215HAN02-0	-	xxx-xxxx-xxx
3	1	53_F-BEZEL-ASM_P215HAN02-0	-	6021P04.001
4	1	53_S8-CDIVER-ASM_P215HAN02-0	-	xxx-xxxx-xxx

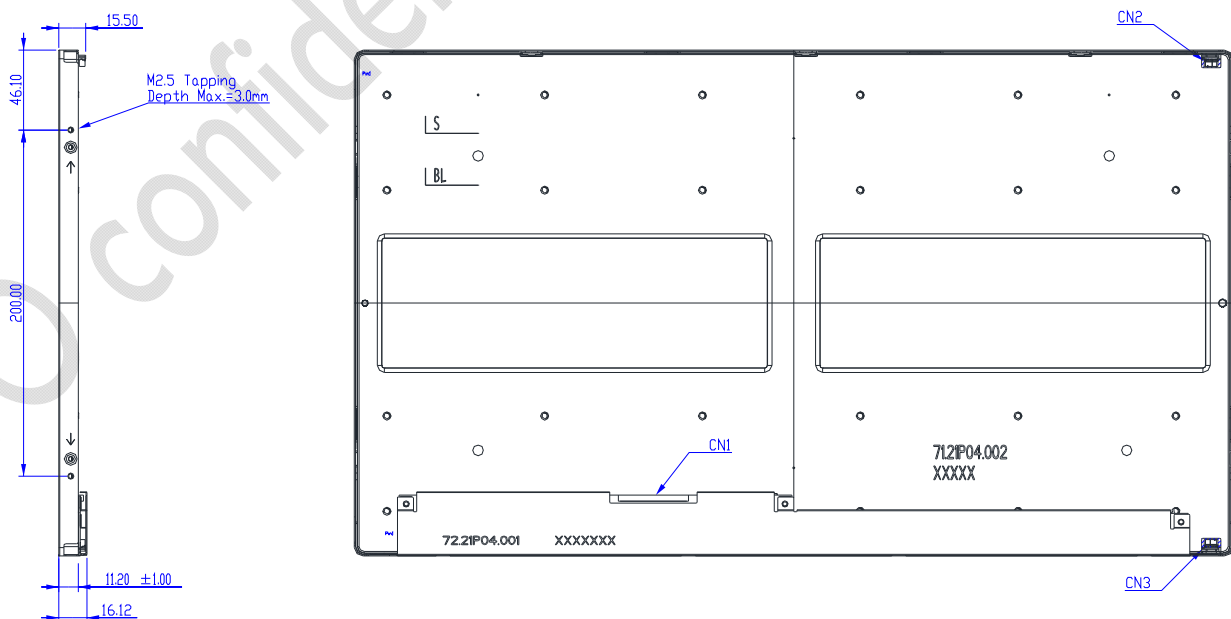
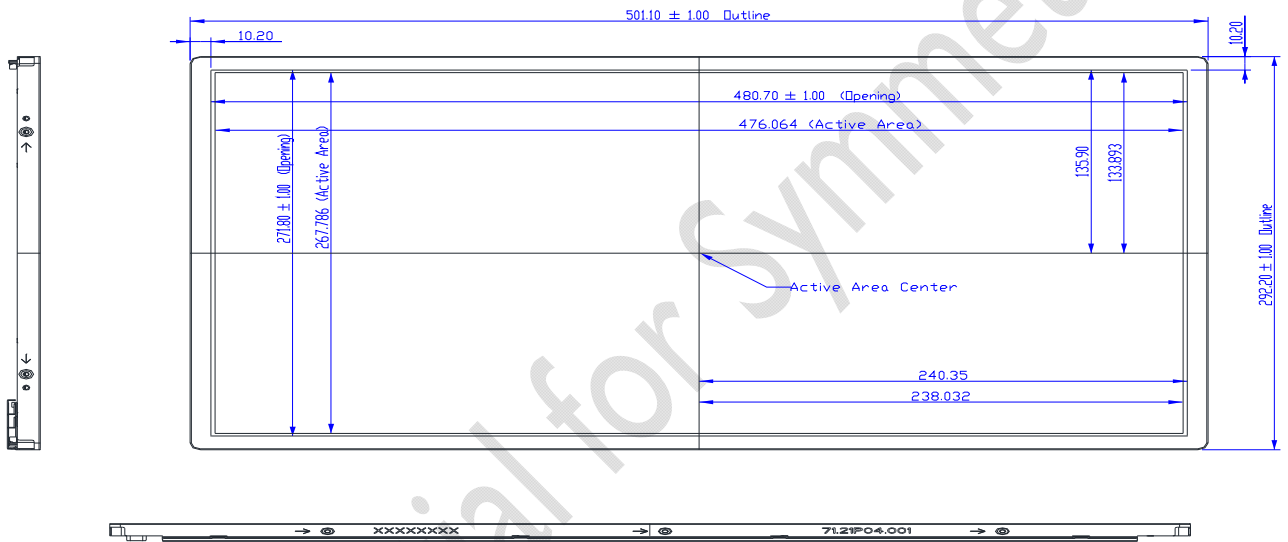

**1.3.3. Absolute Maximum Ratings**

The followings are maximum values which, if exceeded, may cause faulty operation or damage to the unit  
Permanent damage may occur if exceeding the following maximum rating.

Symbol	Description	Min.	Max.	Unit	Remark
TOP	Operating Temperature	0	+50	[°C]	Note 2-1
TGS	Glass surface temperature (operation)	0	+65	[°C]	Note 2-1 Function judged only
HOP	Operation Humidity	5	90	[%RH]	Note 2-1
TST	Storage Temperature	-20	+60	[°C]	
HST	Storage Humidity	5	90	[%RH]	

**Note 2-1:** Temperature and relative humidity range are shown as the below figure.

1. 90% RH Max (  $T_a \leq 39^\circ\text{C}$  )
2. Max wet-bulb temperature at  $39^\circ\text{C}$  or less. (  $T_a \leq 39^\circ\text{C}$  )
3. No condensation

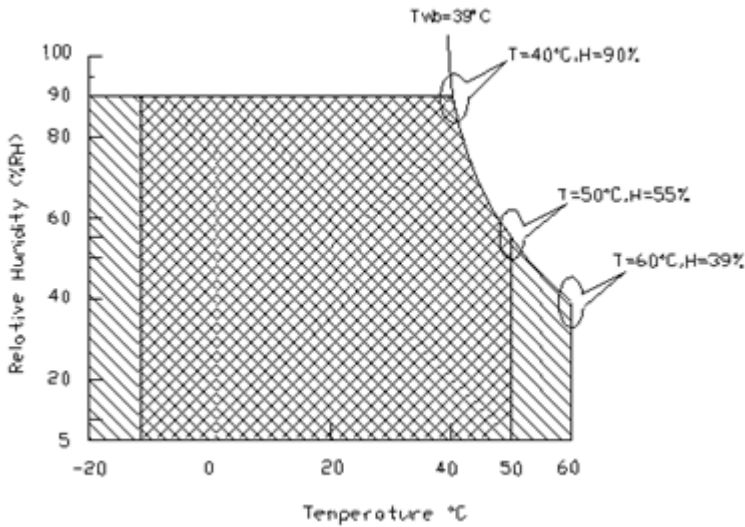

Operating Range



Storage Range

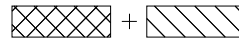

## 2. Electrical Specification

The P215HAN02.0 requires two power inputs. One is employed to power the LCD electronics and to drive the TFT array and liquid crystal. The other is to power Back Light Unit.

### 2.1. Block Diagram

The following shows the block diagram of the 21.5 inch Color TFT-LCD Module.

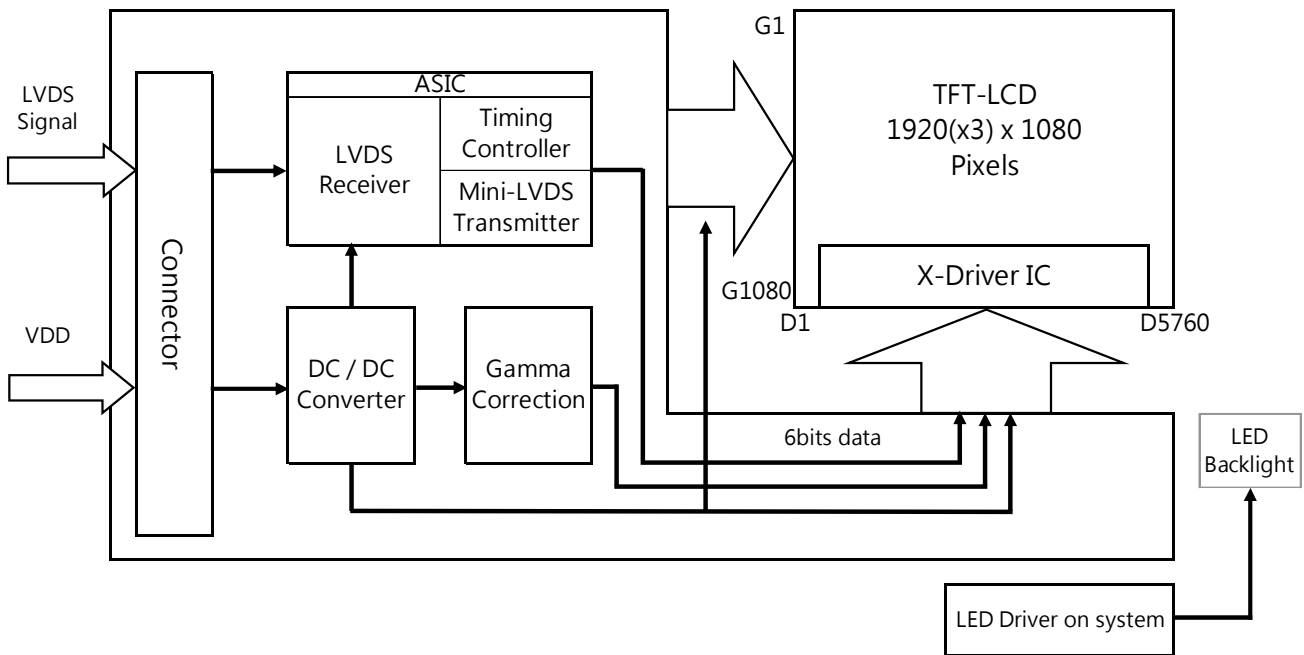

## 2.2. Interface Connection

### 2.2.1. Connector Type

TFT-LCD Connector(CN1)	Manufacturer	P-TWO	STM
	Part Number	187034-3009	MSBKT2407P30HB
Mating Connector	Manufacturer	JAE	
	Part Number	FI-X30HL (Locked Type)	

### 2.2.2. Connector Pin Assignment

PIN #	Symbol	Description	Remark
1	RxO0-	Negative LVDS differential data input (Odd data)	
2	RxO0+	Positive LVDS differential data input (Odd data)	
3	RxO1-	Negative LVDS differential data input (Odd data)	
4	RxO1+	Positive LVDS differential data input (Odd data)	
5	RxO2-	Negative LVDS differential data input (Odd data)	
6	RxO2+	Positive LVDS differential data input (Odd data)	
7	GND	Ground	
8	RxOCLK-	Negative LVDS differential clock input (Odd clock)	
9	RxOCLK+	Positive LVDS differential clock input (Odd clock)	
10	RxO3-	Negative LVDS differential data input (Odd data)	
11	RxO3+	Positive LVDS differential data input (Odd data)	
12	RxE0-	Negative LVDS differential data input (Even data)	
13	RxE0+	Positive LVDS differential data input (Even data)	
14	GND	Ground	
15	RxE1-	Negative LVDS differential data input (Even data)	
16	RxE1+	Positive LVDS differential data input (Even data)	
17	GND	Ground	
18	RxE2-	Negative LVDS differential data input (Even data)	
19	RxE2+	Positive LVDS differential data input (Even data)	
20	RxECLK-	Negative LVDS differential clock input (Even clock)	
21	RxECLK+	Positive LVDS differential clock input (Even clock)	
22	RxE3-	Negative LVDS differential data input (Even data)	
23	RxE3+	Positive LVDS differential data input (Even data)	
24	GND	Ground	
25	NC	No connection (for AUO test only. Do not connect)	
26	NC	No connection (for AUO test only. Do not connect)	
27	NC	No connection (for AUO test only. Do not connect)	
28	VDD	Power Supply Input Voltage	
29	VDD	Power Supply Input Voltage	
30	VDD	Power Supply Input Voltage	

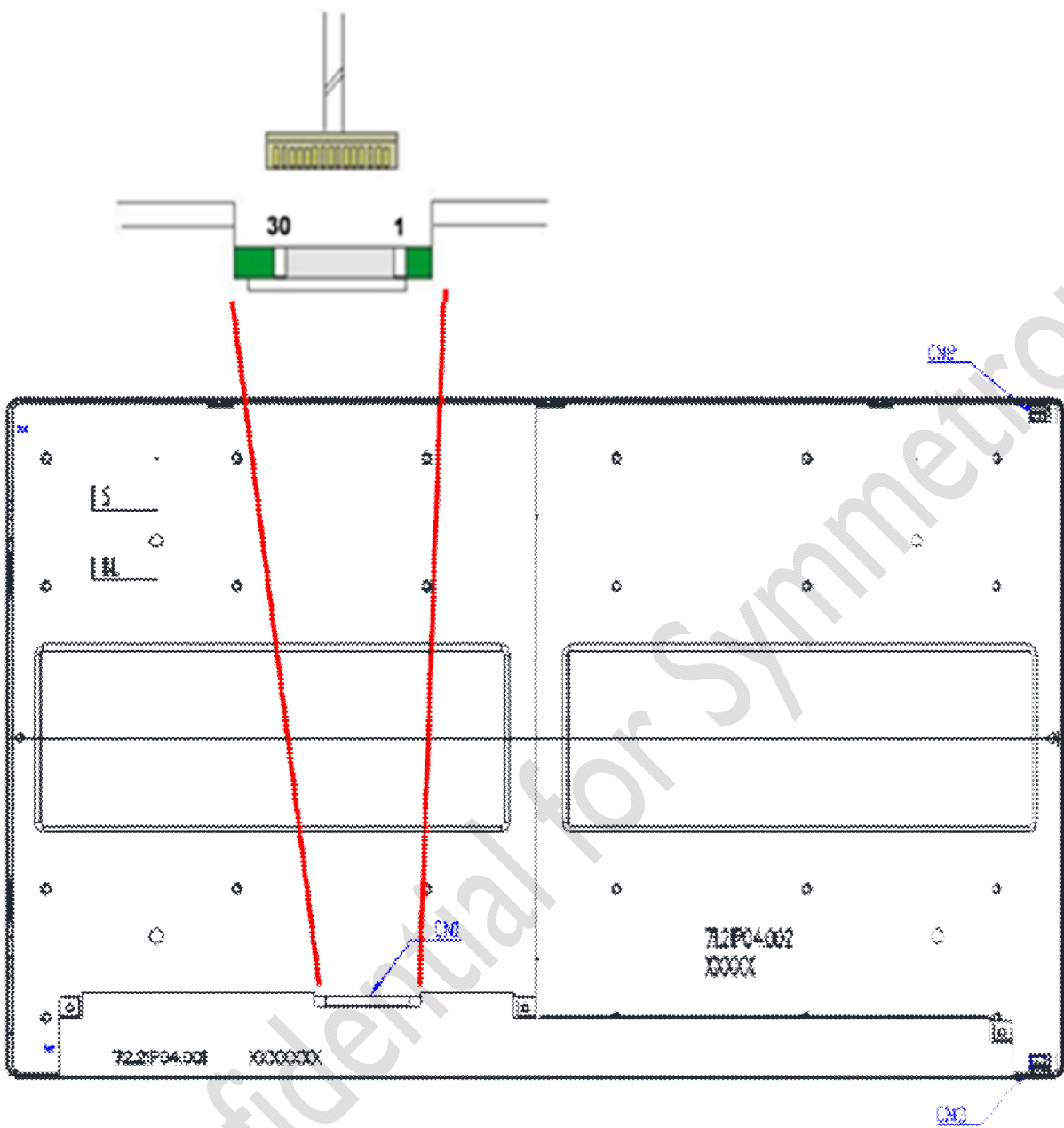



**2.3. Electrical Characteristics**

**2.3.1. Absolute Maximum Rating**

Permanent damage may occur if exceeding the following maximum rating.

Symbol	Description	Min	Max	Unit	Remark
VDD	Power Supply Input Voltage	GND-0.3	6.0	[Volt]	Ta=25°C

**2.3.2. Recommended Operating Condition**

Symbol	Description	Min	Typ	Max	Unit	Remark
VDD	Power supply Input voltage	4.5	5.0	5.5	[Volt]	
IDD	Power supply Input Current (RMS)	-	0.46	0.55	[A]	VDD= 5.0V, All white Pattern, Fv=60Hz
			0.50	0.60	[A]	VDD= 5.0V, All white Pattern, Fv=75Hz
PDD	VDD PowerVDD Power Consumption	-	2.30	2.75	[Watt]	VDD= 5.0V, All white Pattern, Fv=60Hz
			2.50	3.00	[Watt]	VDD= 5.0V, All white Pattern, Fv=75Hz
IRush	Inrush Current	-	-	3.0	[A]	Note 3-1
VDDrp	Allowable VDD Ripple Voltage	-	-	500	[mV]	VDD= 5.0V, All white Pattern, Fv=75Hz
LTLED	LED Life Time	50,000			[Hours]	Note 3-2

**Note 3-1:** Inrush Current measurement:

Test circuit:

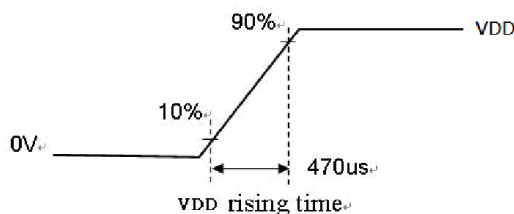
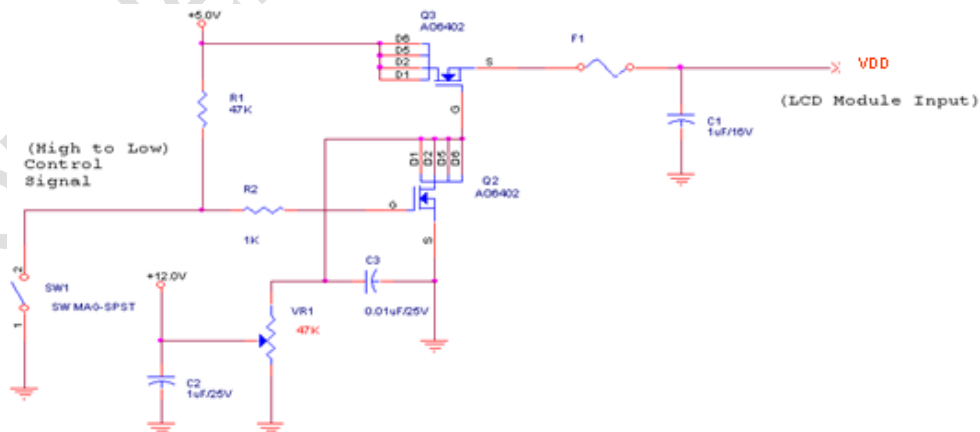

The duration of VDD rising time: 470us.

**Note 3-2:** Definition of life time:

- a. Brightness of LED becomes to 50% of its original value
- b. Test condition:  $I_s = 47\text{mA}$  and  $25^\circ\text{C}$  (Room Temperature)

AUO confidential for Symmetron only

**2.4. Signal Characteristics**

**2.4.1. LCD Pixel Format**

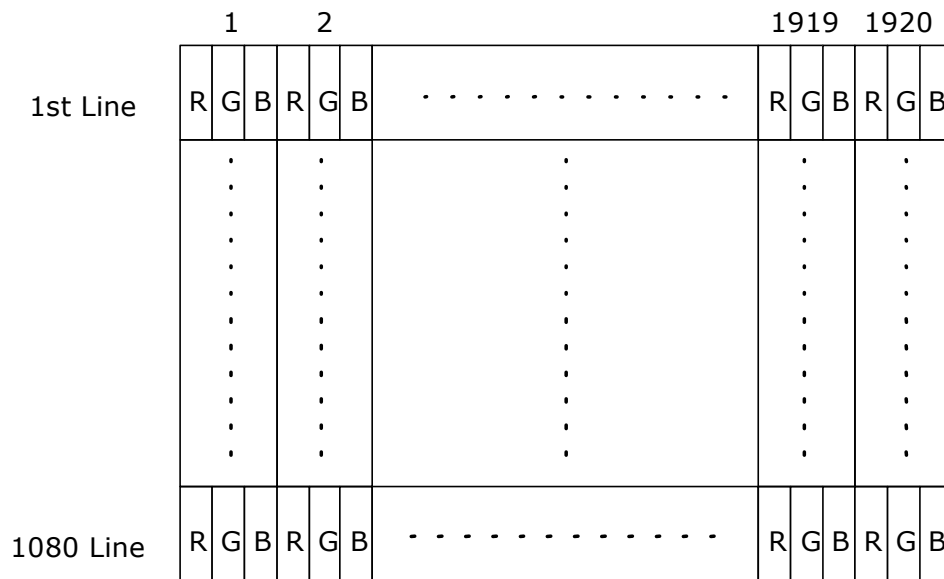

**2.4.2. LVDS Data Format**

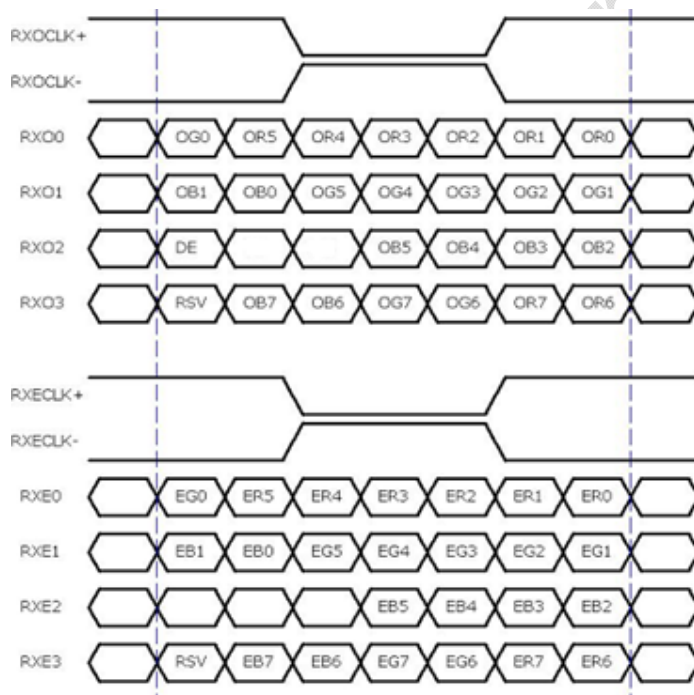

8 Bit Color Bit Order			
MSB	R7	G7	B7
	R6	G6	B6
	R5	G5	B5
	R4	G4	B4
	R3	G3	B3
	R2	G2	B2
	R1	G1	B1
LSB	R0	G0	B0

**Note 3-2:**

- a. O = "Odd Pixel Data" E = "Even Pixel Data"
- b. Refer to 3.4.1 LCD pixel format, the 1st data is 1 (Odd Pixel Data), the 2nd data is 2 (Even Pixel Data) and the last data is 1920 (Even Pixel Data).

**2.4.3. Color versus Input Data**

The following table is for color versus input data (8bit). The higher the gray level, the brighter the color.

Color	Gray Level	Color Input Data																				Remark				
		RED data (MSB:R7, LSB:R0)								GREEN data (MSB:G7, LSB:G0)								BLUE data (MSB:B7, LSB:B0)								
		R7	R6	R5	R4	R3	R2	R1	R0	G7	G6	G5	G4	G3	G2	G1	G0	B7	B6	B5	B4		B3	B2	B1	B0
Black	-	0	0	0	0	0	0	0	0	0	0	0	0	0	0	0	0	0	0	0	0	0	0	0		
White	-	1	1	1	1	1	1	1	1	1	1	1	1	1	1	1	1	1	1	1	1	1	1	1		
Gray 127	-	0	1	1	1	1	1	1	1	0	1	1	1	1	1	1	1	0	1	1	1	1	1	1		
Red	L0	0	0	0	0	0	0	0	0	0	0	0	0	0	0	0	0	0	0	0	0	0	0	0	Black	
	:	:	:	:	:	:	:	:	:	:	:	:	:	:	:	:	:	:	:	:	:	:	:	:		
	L255	1	1	1	1	1	1	1	1	0	0	0	0	0	0	0	0	0	0	0	0	0	0	0		
Green	L0	0	0	0	0	0	0	0	0	0	0	0	0	0	0	0	0	0	0	0	0	0	0	0	Black	
	:	:	:	:	:	:	:	:	:	:	:	:	:	:	:	:	:	:	:	:	:	:	:	:		
	L255	0	0	0	0	0	0	0	0	1	1	1	1	1	1	1	1	0	0	0	0	0	0	0		
Blue	L0	0	0	0	0	0	0	0	0	0	0	0	0	0	0	0	0	0	0	0	0	0	0	0	Black	
	:	:	:	:	:	:	:	:	:	:	:	:	:	:	:	:	:	:	:	:	:	:	:	:		
	L255	0	0	0	0	0	0	0	0	0	0	0	0	0	0	0	0	1	1	1	1	1	1	1		

**2.4.4. LVDS Specification**

**a. DC Characteristics:**

Symbol	Description	Min	Typ	Max	Units	Condition
VTH	LVDS Differential Input High Threshold	-	-	+100	[mV]	VCM = 1.2V
VTL	LVDS Differential Input Low Threshold	-100	-	-	[mV]	VCM = 1.2V
VID	LVDS Differential Input Voltage	100	-	600	[mV]	
VCM	LVDS Common Mode Voltage	+1.0	+1.2	+1.5	[V]	VTH-VTL = 200mV

**LVDS Signal Waveform:**

Use RxOCLK- & RxOCLK+ as example.

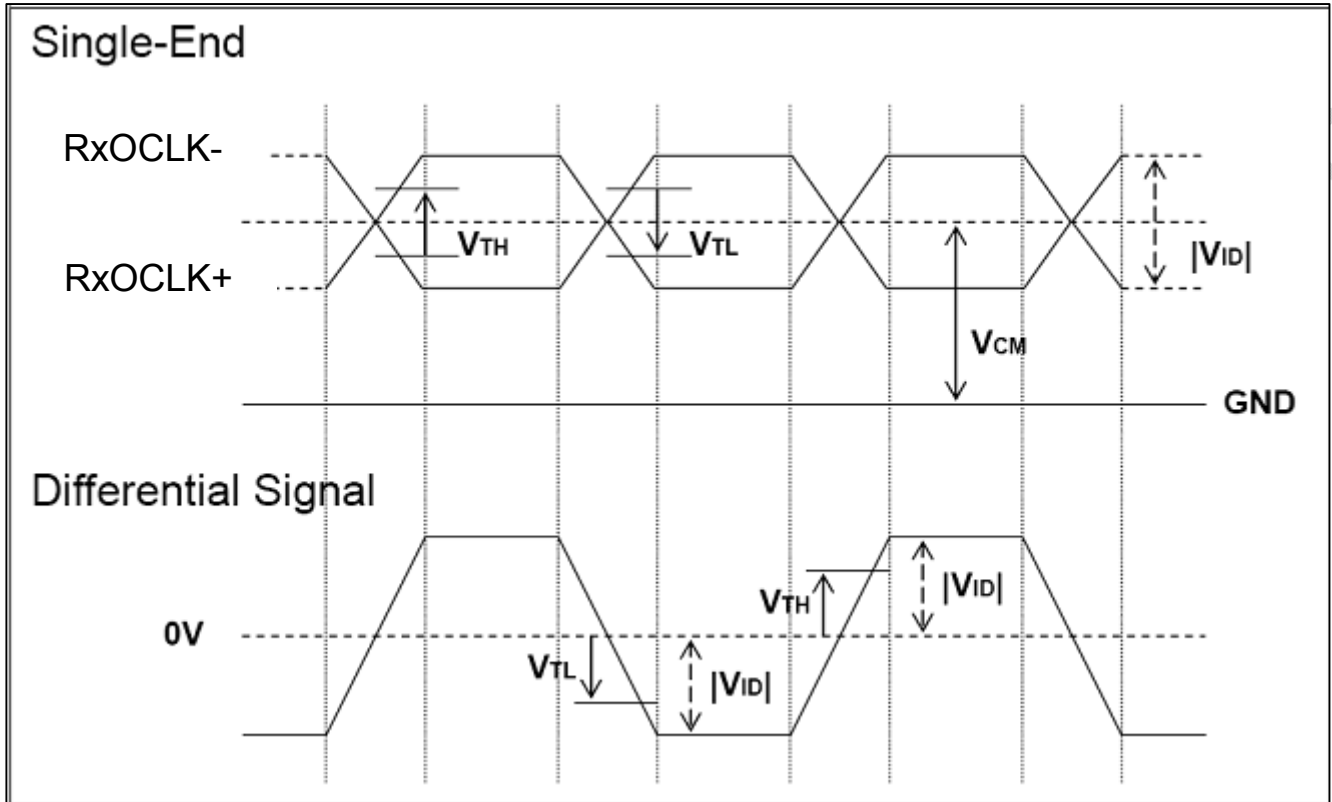

**b. AC Characteristics:**

Symbol	Description	Min	Max	Unit	Remark
FDEV	Maximum deviation of input clock frequency during Spread Spectrum	-	$\pm 3$	%	
FMOD	Maximum modulation frequency of input clock during Spread Spectrum	-	200	KHz	

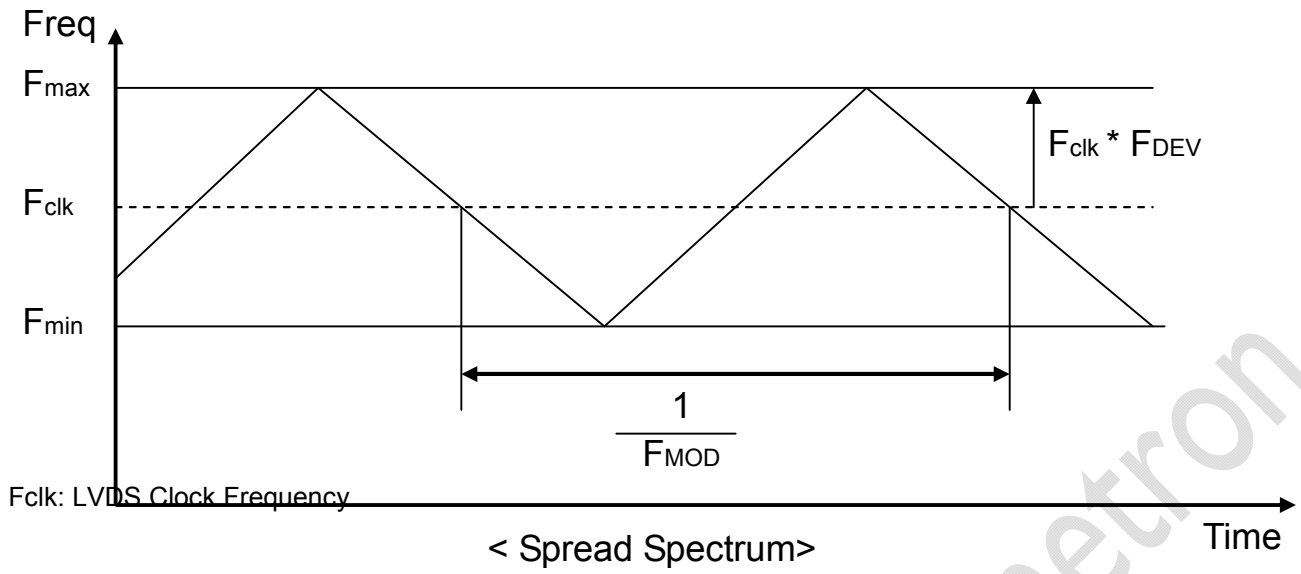

### 2.4.5. Input Timing Specification

It only support DE mode, and the input timing are shown as the following table.

Symbol	Description		Min.	Typ.	Max.	Unit	Remark
Tv	Vertical Section	Period	1094	1130	1836	Th	
Tdisp (v)		Active	1080	1080	1080	Th	
Tblk (v)		Blanking	14	50	756	Th	
Fv		Frequency	49	60	76	Hz	
Th	Horizontal Section	Period	1000	1050	1678	Tclk	
Tdisp (h)		Active	960	960	960	Tclk	
Tblk (h)		Blanking	40	90	718	Tclk	
Fh		Frequency	53.7	67.8	90.0	KHz	<b>Note 3-3</b>
Tclk	LVDS Clock	Period	11.2	14.0	18.6	ns	1/Fclk
Fclk		Frequency	53.7	71.2	90.0	MHz	<b>Note 3-4</b>

**Note 3-3:** The equation is listed as following. Please don't exceed the above recommended value.

$$Fh (\text{Min.}) = Fclk (\text{Min.}) / Th (\text{Min.});$$

$$Fh (\text{Typ.}) = Fclk (\text{Typ.}) / Th (\text{Typ.});$$

$$Fh (\text{Max.}) = Fclk (\text{Max.}) / Th (\text{Min.});$$

**Note 3-4:** The equation is listed as following. Please don't exceed the above recommended value.

$$Fclk (\text{Min.}) = Fv (\text{Min.}) \times Th (\text{Min.}) \times Tv (\text{Min.});$$

$$Fclk (\text{Typ.}) = Fv (\text{Typ.}) \times Th (\text{Typ.}) \times Tv (\text{Typ.});$$

$$Fclk (\text{Max.}) = Fv (\text{Max.}) \times Th (\text{Typ.}) \times Tv (\text{Typ.});$$

**2.4.6. Input Timing Diagram**

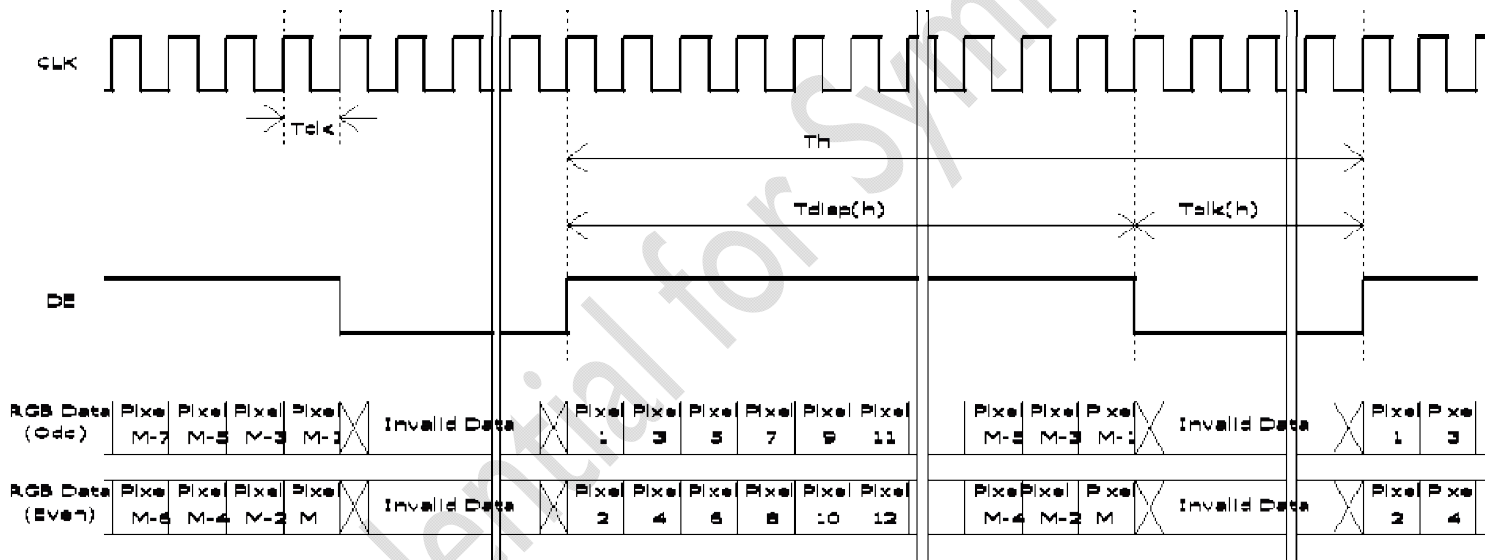
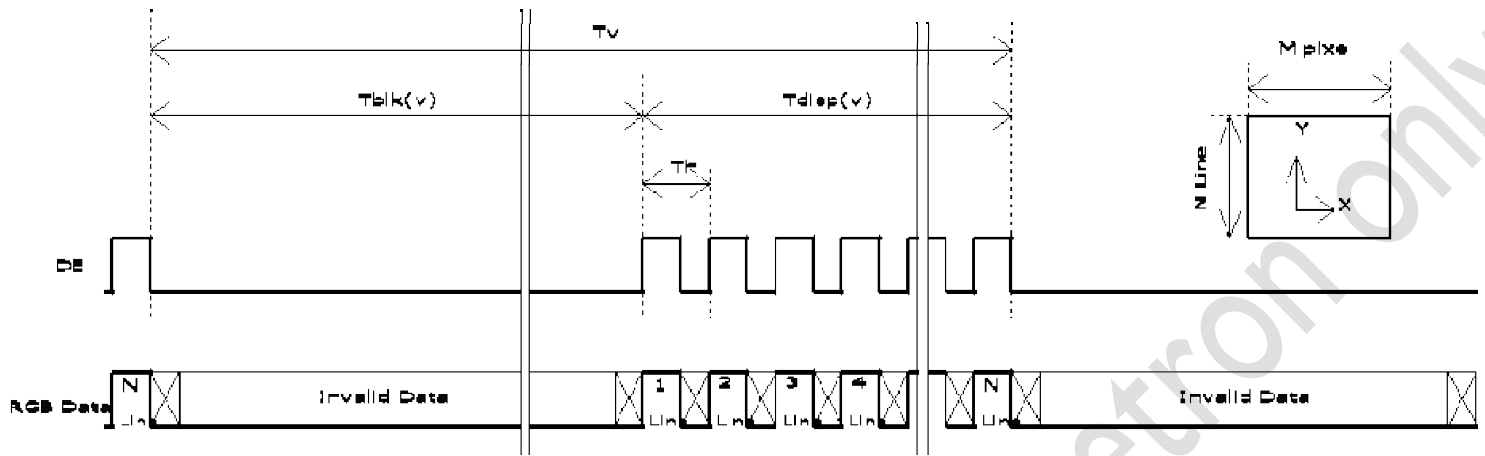



**2.5. Power ON/OFF Sequence**

VDD power, LVDS signal and backlight on/off sequence are as following. LVDS signals from any system shall be Hi-Z state when VDD is off.

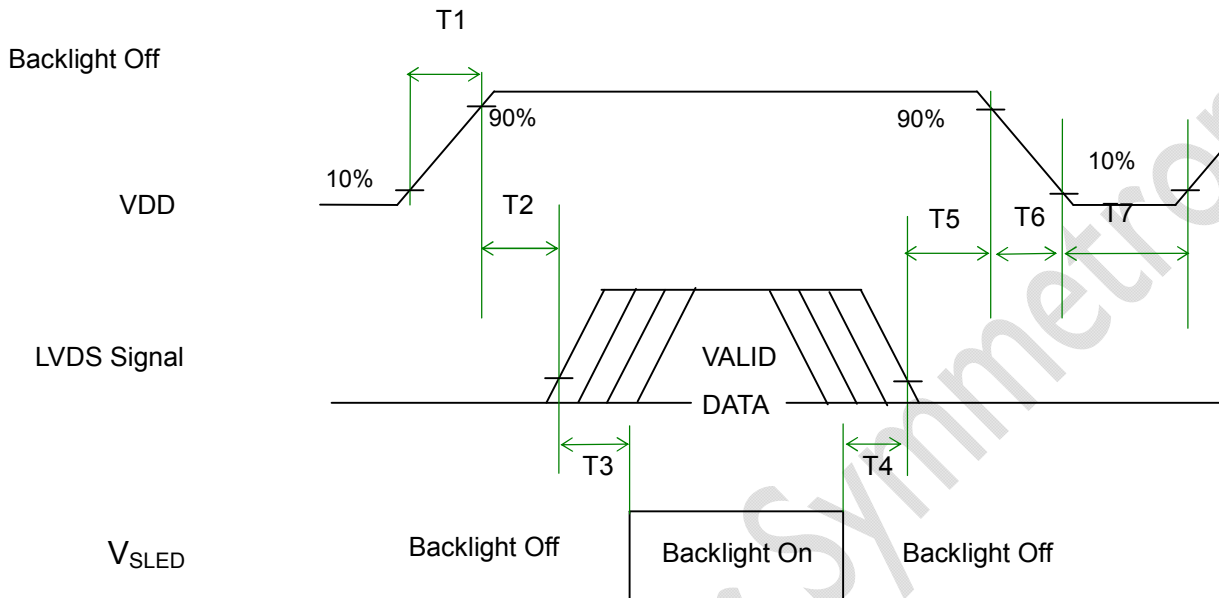

**Power Sequence Timing**

Symbol	Value			Unit	Remark
	Min.	Typ.	Max.		
T1	0.5	-	10	[ms]	
T2	0	-	50	[ms]	
T3	500	-	-	[ms]	
T4	100	-	-	[ms]	
T5	0		50	[ms]	Note 3-5 Note 3-6
T6	0	-	200	[ms]	Note 3-6 Note 3-7
T7	1000	-	-	[ms]	

**Note 3-5 :** Recommend setting T5 = 0ms to avoid electronic noise when VDD is off.

**Note 3-6 :** During T5 and T6 period , please keep the level of input LVDS signals with Hi-Z state.

**Note 3-7 :** Voltage of VDD must decay smoothly after power-off. (customer system decide this value)

### 3. Backlight Unit

#### 3.1. Block Diagram

The following shows the block diagram of the 21.5 inch Backlight Unit. And it's included 2pcs of LED light bar in Backlight Unit. Each of LED light bar is included 68 pcs of LED package.(4 strings with 17 pcs LED of each string).

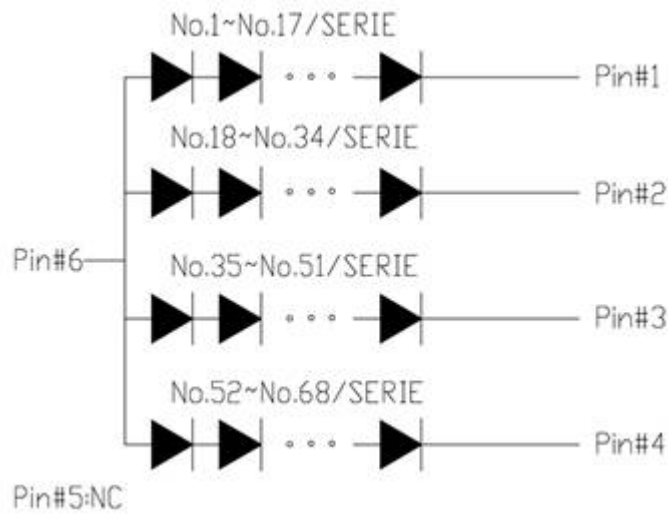

**3.2. Interface Connection**

**3.2.1. Connector Type**

Backlight Connector (CN2/CN3)	Manufacturer	CviLux
	Part Number	CI16M1VRA-NH

**Mating Connector dimension:**

Material:

Base: High temperature plastic UL 94V-0, Color Nature

Contact: Copper alloy

Tab: Copper alloy with Matte Tin plated

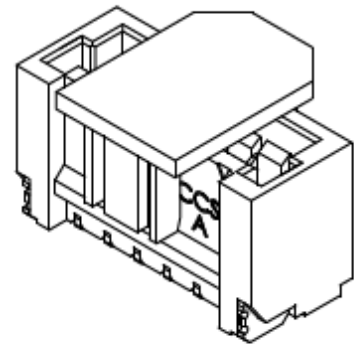
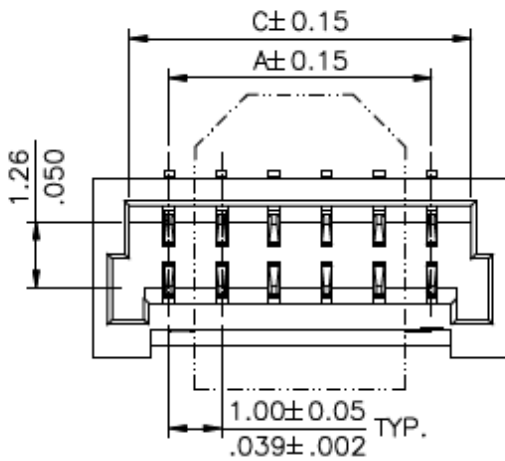

DIM. A = 1.00 x NO. OF SPACES

DIM. B = DIM. A + 2.90

DIM. C = DIM. A + 1.50

\* AVAILABLE IN 2 THROUGH 20

**3.2.2. Connector Pin Assignment**

**CN2**

LED Lightbar Connector Manufacture			CVILUX:CI1606M1VRA-NH
PIN	SYMBOL	FUNCTION	
1	Vc(1)	LED Cathode (Negative)	
2	Vc(2)	LED Cathode (Negative)	
3	Vc(3)	LED Cathode (Negative)	
4	Vc(4)	LED Cathode (Negative)	
5	NC	NC	
6	Va(1)	LED Anode (Positive)	

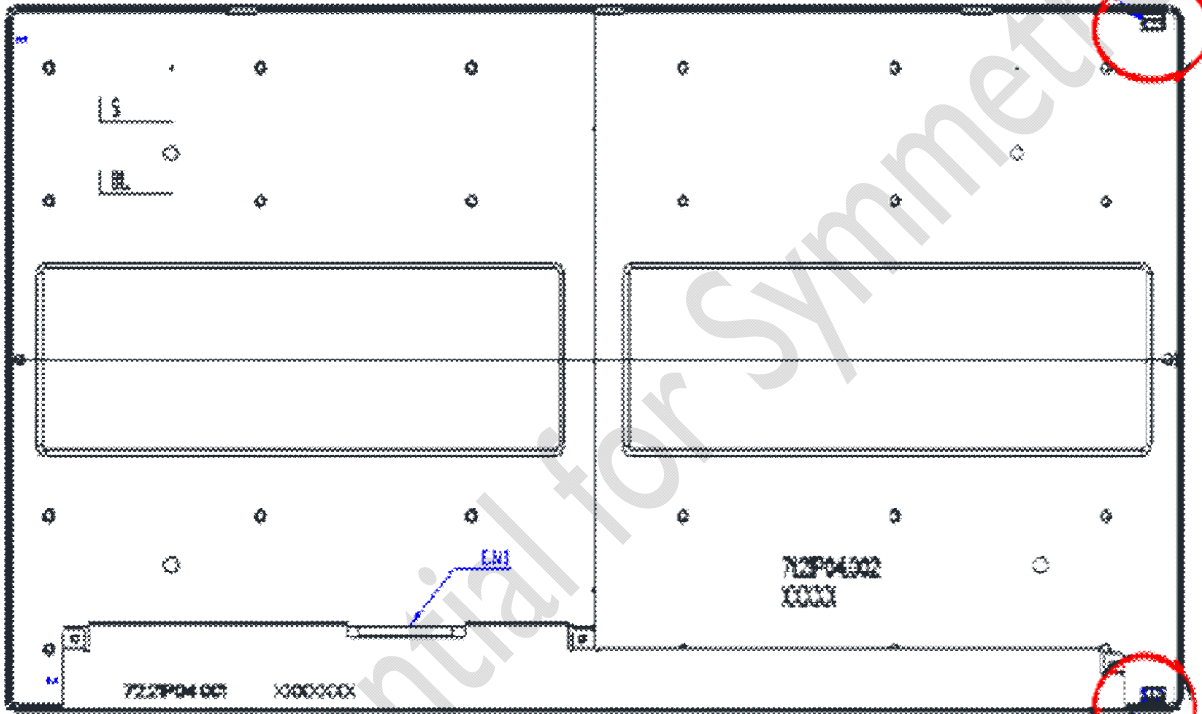

**CN3**

LED Lightbar Connector Manufacture			CVILUX:CI1606M1VRA-NH
PIN	SYMBOL	FUNCTION	
1	Vc(1)	LED Cathode (Negative)	
2	Vc(2)	LED Cathode (Negative)	
3	Vc(3)	LED Cathode (Negative)	
4	Vc(4)	LED Cathode (Negative)	
5	NC	NC	
6	Va(1)	LED Anode (Positive)	

### 3.3. Electrical Characteristics

#### 3.3.1. Absolute Maximum Rating

Permanent damage may occur if exceeding the following maximum rating.

(Ta=25°C)

Symbol	Description	Min	Max	Unit	Remark
Is	LED String Current	0	90	[mA]	100% duty ratio
			120	[mA]	Duty ratio ≤ 10% Pulse time=10 ms

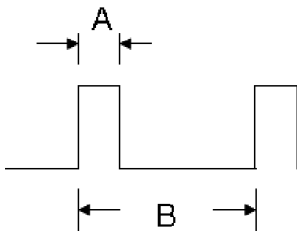

Duty ratio= (A / B) X 100% ; (A: Pulse time, B: Period)

#### 3.3.2. Recommended Operating Condition

(Ta=25°C)

Symbol	Description	Min.	Typ.	Max.	Unit	Remark
Is	LED String Current	-	47		[mA]	100% duty ratio of LED chip, <b>Note 4-4</b>
Vs	LED String Voltage	91.8	95.2	109.3	[Volt]	Is=47mA @ 100% duty ratio; <b>Note 4-1</b>
P <sub>BLU</sub>	LED Light Bar Power Consumption	-	35.8	-	[Watt]	<b>Note 4-2</b>
LT <sub>LED</sub>	LED Life Time	50,000	-	-	[Hour]	<b>Note 4-3</b>

**Note 4-1:**  $V_s (\text{Typ.}) = V_F (\text{Typ.}) \times \text{LED No. (one string)}$ ;

- a.  $V_F$ : LED chip forward voltage,  $V_F (\text{Min.}) = 5.4\text{V}$ ,  $V_F (\text{Typ.}) = 5.6\text{V}$ ,  $V_F (\text{Max.}) = 6.43\text{V}$
- b. The same equation to calculate  $V_s (\text{Min.})$  &  $V_s (\text{Max.})$  for respective  $V_F (\text{Min.})$  &  $V_F (\text{Max.})$ ;

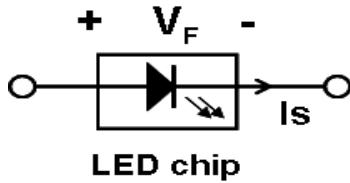

**Note 4-2:**  $P_{\text{BLU}} (\text{Typ.}) = V_s (\text{Typ.}) \times I_s (\text{Typ.}) \times 8$  ; ( 8 is total String No. of LED Light bar)

$P_{\text{BLU}} (\text{Max.}) = V_s (\text{Max.}) \times I_s (\text{Typ.}) \times 8$  ;

**Note 4-3:** Definition of life time:

- a. Brightness of LED becomes to 50% of its original value
- b. Test condition:  $I_s = 47\text{mA}$  and  $25^\circ\text{C}$  (Room Temperature)

**Note 4-4:** AUO strongly recommend "Analog Dimming" method for backlight brightness control for Wavy Noise Free. Otherwise, recommend that Dimming Control Signal (PWM Signal) should be synchronized with Frame Frequency.

## 4. Reliability Test Items

AUO reliability test items are listed as following table. (*Bare Panel only*)

Items	Condition	Remark
High temperature storage test	60°C , 500hrs	
Low temperature storage test	-20°C , 500hrs	
High temperature operation test	50°C , 500hrs	
Low temperature operation test	0°C , 500hrs	
Vibration test (With carton)	Random wave (1.04Grms 2~200Hz)	
Drop test (With carton)	Height: 25.4 cm Direction: Only bottom flat twice (ASTMD4169-I)	

## **5. International Standard**

### **5.1. Safety**

- (1) UL 60950-1; Standard for Safety of Information Technology Equipment Including electrical Business Equipment.
- (2) IEC 60950-1; Standard for Safety of International Electrotechnical Commission
- (3) EN 60950-1; European Committee for Electrotechnical Standardization (CENELEC), EUROPEAN STANDARD for Safety of Information Technology Equipment Including Electrical Business Equipment.

### **5.2. EMC**

- (1) ANSI C63.4 "Methods of Measurement of Radio-Noise Emissions from Low-Voltage Electrical and Electrical Equipment in the Range of 9kHz to 40GHz. "American National standards Institute(ANSI), 1992
- (2) C.I.S.P.R "Limits and Methods of Measurement of Radio Interface Characteristics of Information Technology Equipment." International Special committee on Radio Interference.
- (3) EN 55022 "Limits and Methods of Measurement of Radio Interface Characteristics of Information Technology Equipment." European Committee for Electrotechnical Standardization. (CENELEC), 1998



## 6. Packing

### 6.1. Definition of Label

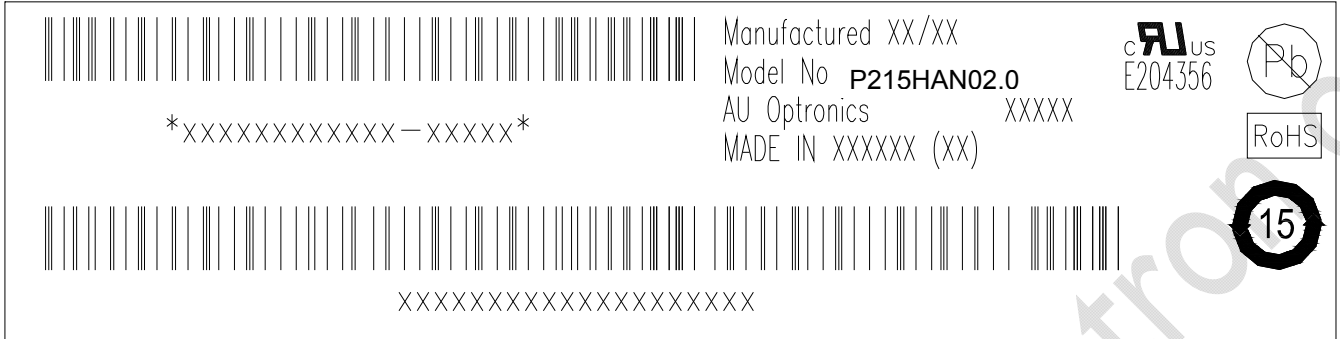

#### Green mark description

(1) For Pb Free Product, AUO will add  for identification.

(2) For RoHs compatible products, AUO will add  for identification.

Note: The green Mark will be present only when the green documents have been ready by AUO internal green team. (definition of green design follows the AUO green design checklist.)

**6.2. Packing Methods**

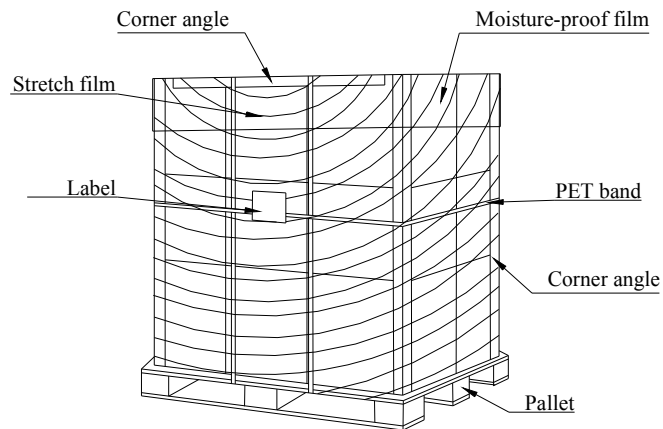
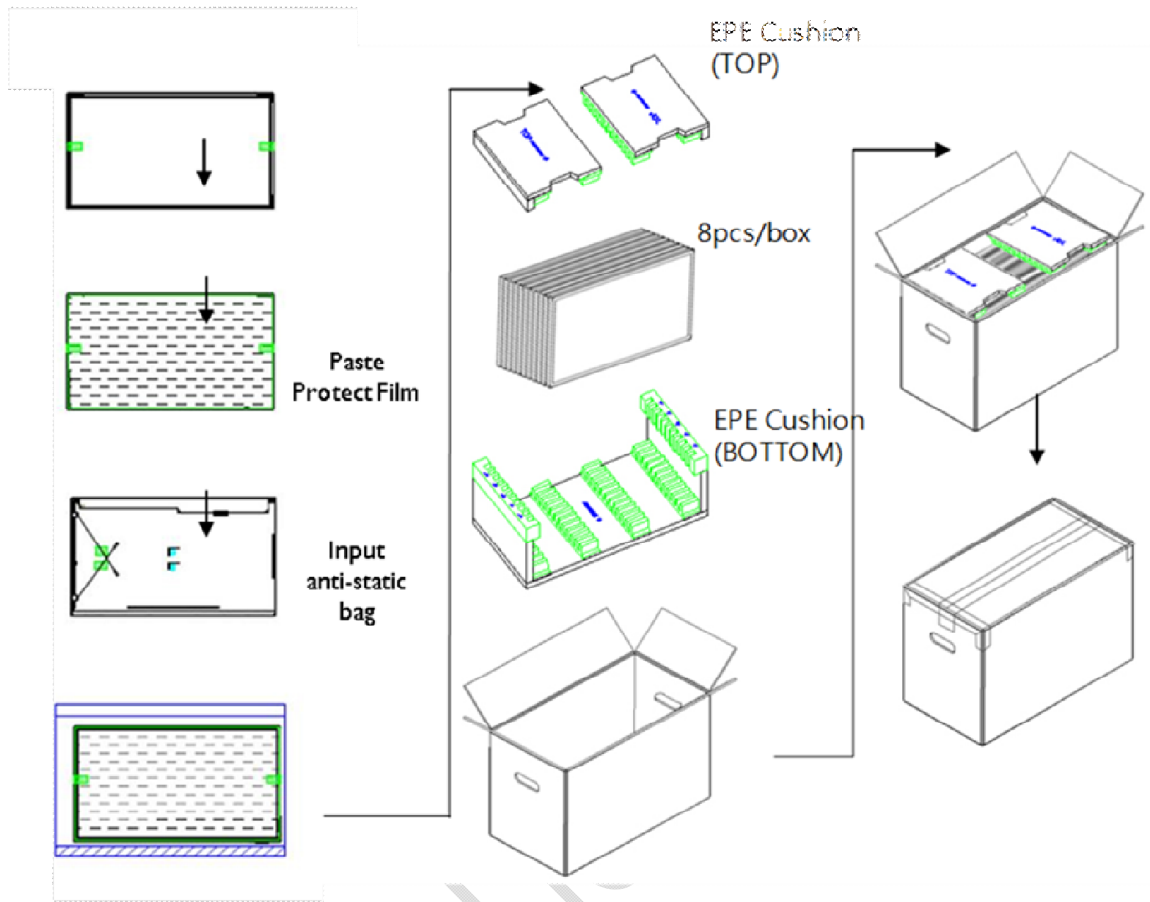

Pallet and Shipment Information

	Item	Specification			Remark
		Q'ty	Dimension	Weight(kg)	
1	Panel	1	501.1mm(H) × 292.2mm(V) × 16.3(D)mm	2.058	<b>Note 1</b>
2	Cushion	1	-	0.55	
3	Box	1	556(L)mm × 292(W)mm × 375(H)mm	1.40	without Panel & cushion <b>Note 1</b>
4	Packing Box	8 pcs/Box	556(L)mm × 292(W)mm × 375(H)mm	18.41	with panel & cushion <b>Note 1</b>
5	Pallet	1	1150(L)mm × 910(W)mm × 132(H)mm	13.8	<b>Note 1</b>
6	Pallet after Packing	18 boxes/pallet	1150(L)mm × 910(W)mm × 1257(H)mm	345.18	<b>Note 1</b>

**Note 1:** Estimated value which is subject to change based on real measured data.

## 7. Precautions

### 7. Precautions

Please pay attention to the followings when you use this TFT LCD module.

#### 7.1. Mounting Precautions

- (1) You must mount a module using holes arranged in four corners or four sides.
- (2) You should consider the mounting structure so that uneven force (ex. twisted stress) is not applied to module. And the case on which a module is mounted should have sufficient strength so that external force is not transmitted directly to the module.
- (3) Please attach the surface transparent protective plate to the surface in order to protect the polarizer. Transparent protective plate should have sufficient strength in order to resist external force.
- (4) You should adopt radiation structure to satisfy the temperature specification.
- (5) Acetic acid type and chlorine type materials for the cover case are not desirable because the former generates corrosive gas of attacking the polarizer at high temperature and the latter cause circuit broken by electro-chemical reaction.
- (6) Do not touch, push or rub the exposed polarizer with glass, tweezers or anything harder than HB pencil lead. And please do not rub with dust clothes with chemical treatment. Do not touch the surface of polarizer for bare hand or greasy cloth. (Some cosmetics are detrimental to the polarizer.)
- (7) When the surface becomes dusty, please wipe gently with absorbent cotton or other soft materials like chamois soaks with petroleum benzene. Normal-hexane is recommended for cleaning the adhesives used to attach front/ rear polarizer. Do not use acetone, toluene and alcohol because they cause chemical damage to the polarizer.
- (8) Wipe off saliva or water drops as soon as possible. Their long time contact with polarizer causes deformations and color fading.
- (9) Do not open the case because inside circuits do not have sufficient strength.
- (10) To keep display functional well as a digital signage application, especially the component of TFT is very sensitive with sunlight, it is necessary to set up blocking device protecting panel from radiation of ambient environment.

#### 7.2. Operating Precautions

- (1) The spike noise causes the mis-operation of circuits. It should be lower than following voltage:  
V=±200mV(Over and under shoot voltage)
- (2) Response time depends on the temperature. (In lower temperature, it becomes longer..)
- (3) Brightness depends on the temperature. (In lower temperature, it may become lower.) And in lower temperature, response time (required time that brightness is stable after turned on) becomes longer.

- (4) Be careful for condensation at sudden temperature change. Condensation makes damage to polarizer or electrical contacted parts. And after fading condensation, smear or spot will occur.
- (5) When fixed patterns are displayed for a long time, remnant image is likely to occur.
- (6) Module has high frequency circuits. Sufficient suppression to the electromagnetic interference shall be done by system manufacturers. Grounding and shielding methods may be important to minimize the interface.

### 7.3. Operating Condition for Public Information Display

The device listed in the product specification is designed and manufactured for PID (Public Information Display) application. To optimize module's lifetime and function, below operating usages are required.

- (1) Normal operating condition
  - A. Operating temperature: 0~50°C
  - B. Operating humidity: 10~90%
  - C. Display pattern: dynamic pattern (Real display).  
Note) Long-term static display would cause image sticking.
- (1) Operation usage to protect against image sticking due to long-term static display.
  - A. Suitable operating time: 16 hours a day or less.  
(\* The moving picture can be allowed for 24 hours a day)
  - B. Liquid Crystal refresh time is required. Cycling display between 5 minutes' information (static) display and 10 seconds' moving image.
  - C. Periodically change background and character (image) color.
  - D. Avoid combination of background and character with large different luminance.
- (2) Periodically adopt one of the following actions after long time display.
  - A. Running the screen saver (motion picture or black pattern)
  - B. Power off the system for a while
- (3) LCD system is required to place in well-ventilated environment. Adapting active cooling system is highly recommended.
- (4) Product reliability and functions are only guaranteed when the product is used under right operation usages. If product will be used in extreme conditions, such as high temperature/humidity, display stationary patterns, or long operation time etc..., it is strongly recommended to contact AUO for filed application engineering advice. Otherwise, its reliability and function may not be guaranteed. Extreme conditions are commonly found at airports, transit stations, banks, stock market and controlling systems.

### 7.4. Electrostatic Discharge Control

Since a module is composed of electronic circuits, it is not strong to electrostatic discharge. Make certain that treatment persons are connected to ground through wristband etc. And don't touch interface pin directly.

### **7.5. Precautions for Strong Light Exposure**

Strong light exposure causes degradation of polarizer and color filter.

### **7.6. Storage**

When storing modules as spares for a long time, the following precautions are necessary.

- (1) Store them in a dark place. Do not expose the module to sunlight or fluorescent light. Keep the temperature between 5°C and 35°C at normal humidity.
- (2) The polarizer surface should not come in contact with any other object. It is recommended that they be stored in the container in which they were shipped.
- (3) Storage condition is guaranteed under packing conditions.
- (4) The phase transition of Liquid Crystal in the condition of the low or high storage temperature will be recovered when the LCD module returns to the normal condition.

### **7.7. Handling Precautions for Protection Film**

- (1) The protection film is attached to the bezel with a small masking tape. When the protection film is peeled off, static electricity is generated between the film and polarizer. This should be peeled off slowly and carefully by people who are electrically grounded and with well ion-blown equipment or in such a condition, etc.
- (2) When the module with protection film attached is stored for a long time, sometimes there remains a very small amount of glue still on the bezel after the protection film is peeled off.

You can remove the glue easily. When the glue remains on the bezel or its vestige is recognized, please wipe them off with absorbent cotton waste or other soft material like chamois soaked with normal-hexane.