

REVISION RECORD					
REV	ECO	DESCRIPTION	DRFT	DATE	
①		产品名称由DG46A变更为DG46S	WF	02/21/06*	
②		增加UL刻字	CSX	09/30/06*	
③		增加R0.9半圆柱特征	Mickey	06/05/09*	

NOTES:

1. Pitch: 9.5mm , Poles: 2p-26p;
2. Rated: 300V/20A;
3. Temp. Range: -40° C ~ +105° C;
4. Withstand Voltage: AC2000V/1min;
5. Wire Range: 22-12AWG;
6. Insulation Resistance: 500MΩ/DC500V;
7. Max. Torque Value: 12.24Kgf.cm
8. Undimensioned Tolerances:

Pitch range in mm		Nominal dimension range in mm					
to 6	over 6 to 10	over 10 to 24	over 6 to 30	over 30 to 90	over 90 to 200	over 200 to 480	—
	±0.10	±0.15	±0.25	±0.1	±0.2	±0.3	±0.5
							±0.7
							±0.05/0

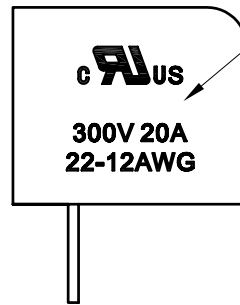
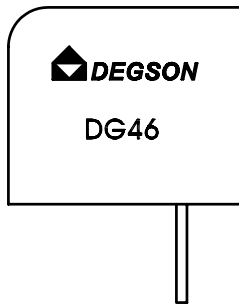
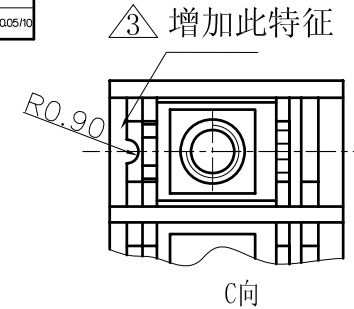
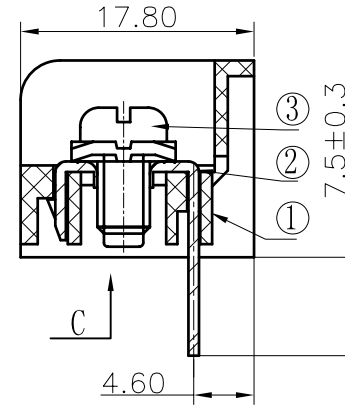
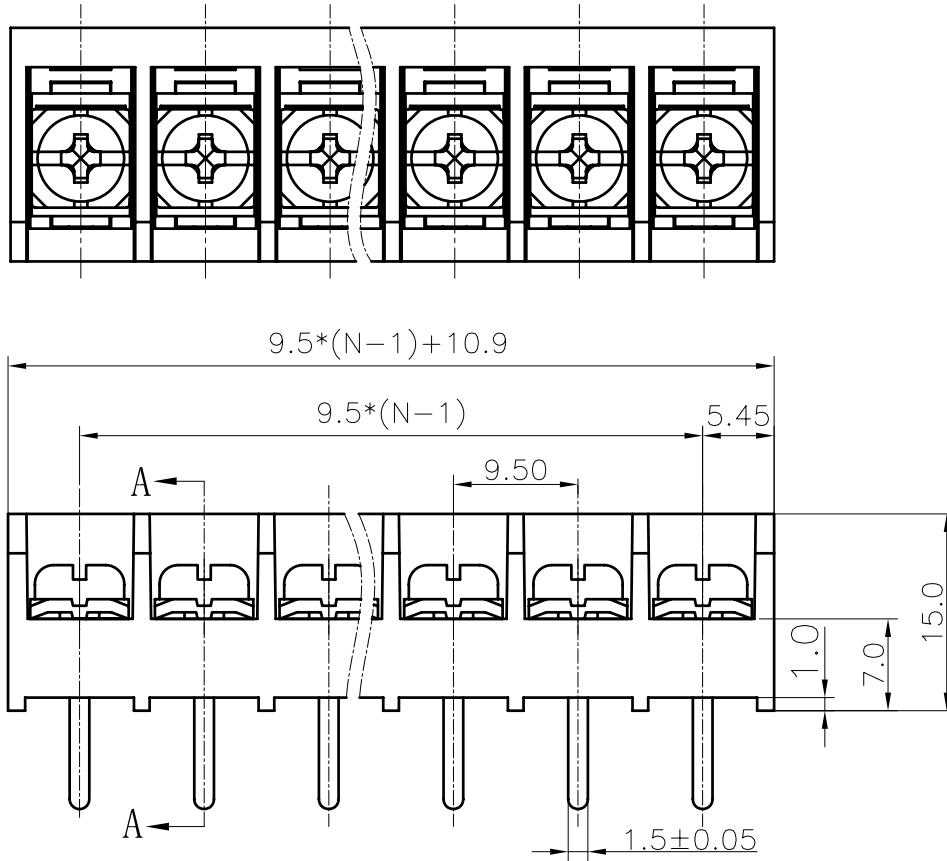

ITEM	NAME OF PART	NO. OF PART	Q'TY	MATERIAL	NOTES
1	DG46S-B Housing	5012A0YXXA (H)	1	PA66	UL94V-0

MM (INCH)	DFTO Home	DATE 01/05/06*	宁波高正电子有限公司 DEGSON ELECTRONICS CO., LTD
TOLERANCES EXCEPT AS NOTED	CHRD	DATE	
	MFO	DATE	
	APPLY	DATE	
MM			MATERIAL :
.0 ±	±		
.00 ±	±		
.000 ±	±		
ANGLES ± 1°	G. E :		NAME DG46S-B-XXP-1Y-00A (H)
THIRD ANGLE PROJECTION	FINISH :		DRAWING NO. DG46S-E14
	SCALE : 1:1		/PART NO.
DO NOT SCALE DRAWING			SIZE A3
SHEET 1 OF 1			REV T3 06/05/09*

3	M4*8 (7.5*7.5) bright screws	S000000570 (H)	XX	Steel	Ni plated
2	DG46S Pin header	5012B00030 (H)	XX	Brass	SnCe