



ACME Electronics Corporation

越峰電子材料股份有限公司



客户
CUSTOMER

PLATAN

日期
DATE 2023/5/25

认 可 书
SPECIFICATION FOR APPROVAL

客产品名 CUSTOMER P/N	672121.069	
越峰品名 ACME P/N	AMATR23133BX	
版本号 REV. NO.	0	

为保证订单顺利完成，请在一个月内签回。否则，将默认贵司同意依此份认可书内容制作您所有此规格的订单产品。

In order to ensure the leadtime for your order, pls confirm and sign this spec for ACME within one month while you received it. Or else, it means that you have approved this spec, and you have agreed with that ferrite cores from your order be produced according to this spec.

客户认可 APPROVED BY :

如有客户品码 (料号) · 请填写在下
客户品码 (料号) :
CUSTOMER P/N

- 厂别 Factory
- 总公司：台北市内湖区基湖路39号8楼B室
Head Office: 8th Floor, No.39, Ji-Hu Rd., Nei-Hu Dist., Taipei 114, Taiwan, R.O.C.
Tel: +886-2-2798-0337 Fax: +886-2-2659-9511 E-Mail: sales@acme-ferrite.com.tw
 - 观音厂：台湾省桃园县328观音工业区国建二路2号
No.2, Kuo-Chien 2nd Rd, Kuan-Yin Industrial District, Taoyuan County 328, Taiwan, R.O.C.
Tel: +886-3-483-7238 Fax: +886-3-483-7239
 - 广州厂：越峰电子(广州)有限公司 / 中国广东省广州增城市增江街东区府前东路2号
No.2 Fuqian East Road, Zengjiang Street East Square, Guangzhou-Zengcheng City, Guangdong Province, China.
Tel: +86-20-3285-1888 Fax: +86-20-3285-1666
 - 昆山厂：越峰电子(昆山)有限公司 / 中国江苏省昆山市黄浦江北路533号
No.533, Huangpujiang North Rd., Kunshan City
Tel: +86-512-5793-2888 Fax: +86-512-5766-4667

批准	审核	拟制
APPROVED BY	CHECKED BY	PREPARED BY
Jeff	Jeff	Jackson

申請單號：



ACME Electronics Corporation

越峰電子材料股份有限公司

历史变更记录

REVISION RECORDS LIST

客户 CUSTOMER:	PLATAN	CUSTOMER P/N	672121.069
		ACME P/N	AMATR23133BX

更改记录 REVISION RECORD:

版本号 REV. NO.	更改内容及原因 CONTENTS AND REASONS	日期 DATE OF APPROVAL	担当 DRAWN
0	NEW SPEC	2023/5/25	Jeff Liu



1. 绕线数据表 Winding Data

绕组编号 Coil No.	开始 Start	结束 Finish	圈数 Turns	绕线方向 Direction	漆包线 Wire	胶带圈数 Tape Turns	挡墙胶带 Margin Tape		起線套管 Tube	收線套管 Tube
							Pin1-9	Pin10-18		
N1	4	2	28	CLOSED	UEW Ø0.25*1C	6.0mm*2Ts	/	/	/	/
N2	6	7	15	CLOSED	UEW Ø0.25*1C	6.0mm*2Ts	/	/	/	/
N3	9	10	15	CLOSED	UEW Ø0.25*1C	6.0mm*2Ts	/	/	/	/

2. 原理及绕线图 Circuit Diagram

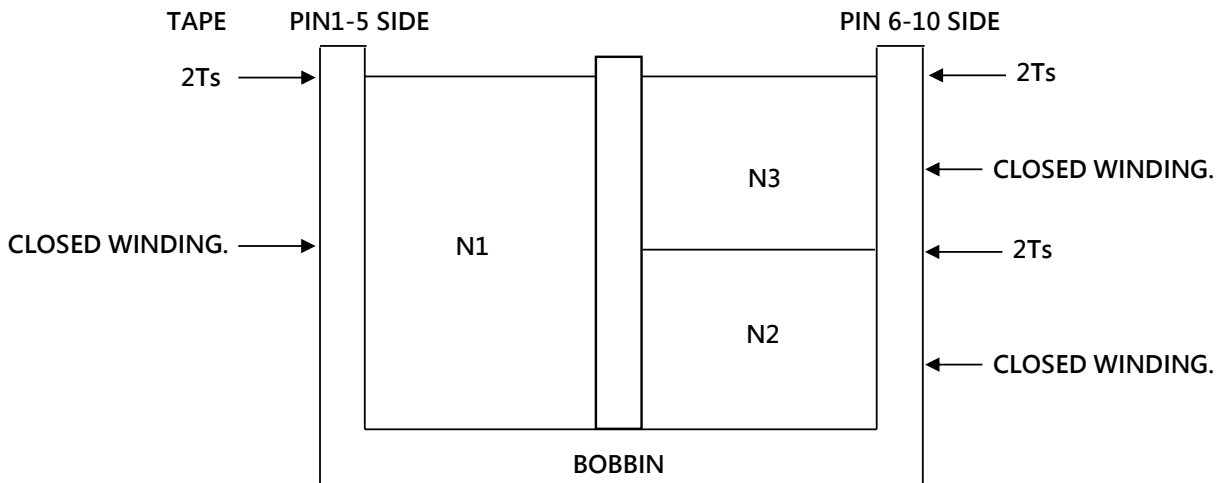
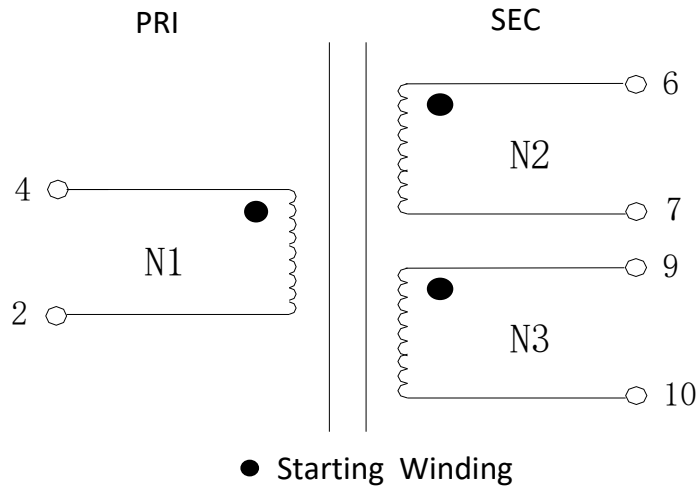

NOTE :

1. PIN 1,3,5,8 CUT OFF.

CUSTOMER P/N	672121.069
ACME P/N	AMATR23133BX

版本号REV: 0



3.外形尺寸Outer Dimension(mm)

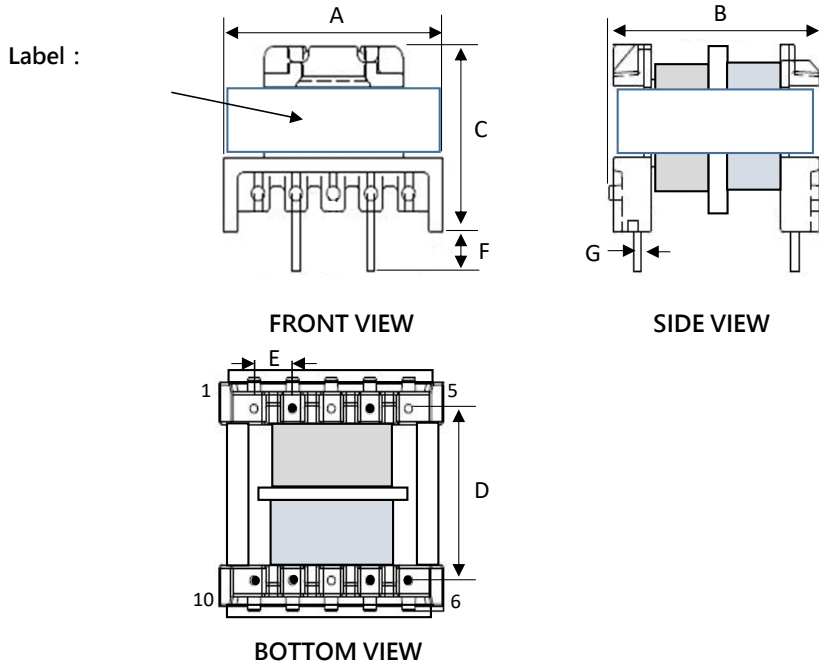

Note:

1.CORE TAPE 1mil*5.0mm*3.0Ts

4.电气性能测试Electrical test

项目Item	L1 (4-2)	L2 (6-7)	L3 (9-10)	HI-POT Pri-Sec	HI-POT Pri-Core	HI-POT Sec-Core							
规格Specification	1230uH	353uH	353uH	AC1500	AC1000	AC1000V							
公差Tolerance	±30%	±30%	±30%	V/3mA/ 3sec	V/3mA/ 3sec	/3mA/ 3sec							
测试条件Test Condition	10KHz/ 0.05Vac												
样品1Sample1													
样品2Sample2													
样品3Sample3													
样品4Sample4													
样品5Sample5													
样品最小值Min	0.00	0.00	0.00										
样品最大值Max	0.00	0.00	0.00										
Range R差	0.00	0.00	0.00										
样品平均值Average	#DIV/0!	#DIV/0!	#DIV/0!										

5.机械尺寸测试Mechanical test (单位Unit:mm)

项目Item	A	B	C	D	E	F	G						
规格Specification	22.5mm	24.0mm	17.5mm	15.24mm	3.8mm	3.5mm	0.8mm						
公差Tolerance	MAX	MAX	MAX	±0.5	±0.5	±0.5	±0.05						
样品1Sample1													
样品2Sample2													
样品3Sample3													
样品4Sample4													
样品5Sample5													
样品最小值Min	0.00	0.00	0.00	0.00	0.00	0.00	0.00						
样品最大值Max	0.00	0.00	0.00	0.00	0.00	0.00	0.00						
Range R差	0.00	0.00	0.00	0.00	0.00	0.00	0.00						
样品平均值Average	#DIV/0!	#DIV/0!	#DIV/0!	#DIV/0!	#DIV/0!	#DIV/0!	#DIV/0!						

PIN拉力PIN tension load : > 1.0kg

CUSTOMER P/N	672121.069
ACME P/N	AMATR23133BX

版本号REV: 0



7. 包装方式Packaging



Box size : L300*W240*H23mm

1 inner box : 150 pcs

Number of inner boxes: 10 boxes in total

Packing quantity : 150pcs*10 boxes = 1500 PCS

NOTE :

1. The product is placed upright in the inner box for a total of 150PCS.

2. The inner box is wrapped with tape, put into the outer box, the outer box label card is pasted on the outside of the outer box, and a piece of pearl cotton is placed to fill the gap.

3. QA inspection report is attached when shipping.

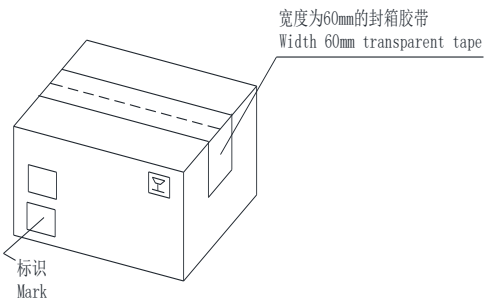

外形尺寸Outer Dimension: 320mm*260mm*155mm

包装重量Pack Weight: G.W kg (g/pcs)

CUSTOMER P/N	672121.069
ACME P/N	AMATR23133BX

版本号REV: 0