

ST2225A

Version : A.025
Issue Date : 2001/11/26
File Name : SP-ST2225A-A.025.doc
Total Pages : 12

LED Display Driver



ST2225A

LED Display Driver

General Description

The ST2225A LED display driver is a monolithic CMOS IC. In order to achieve continuous brightness control, the LED display brightness is controlled by setting a reference current through a variable resistor connected between a supply and a single pin.

Features

- Continuous brightness control
- Serial data input
- No load signal required for data latch
- Wide power supply operation
- TTL compatibility
- 35 outputs, 20mA capability
- Small package, SSOP48 and bare chip form

Applications

- Industrial control indicator
- Relay driver
- Digital clock, thermometer, counter, voltmeter
- Instrumentation readouts

Ordering Information

Part Number	Temp. Range	Package
ST2225A-SS3	-40 to +85°C	SSOP48
ST2225A-D	-40 to +85°C	Bare Chip

Block Diagram

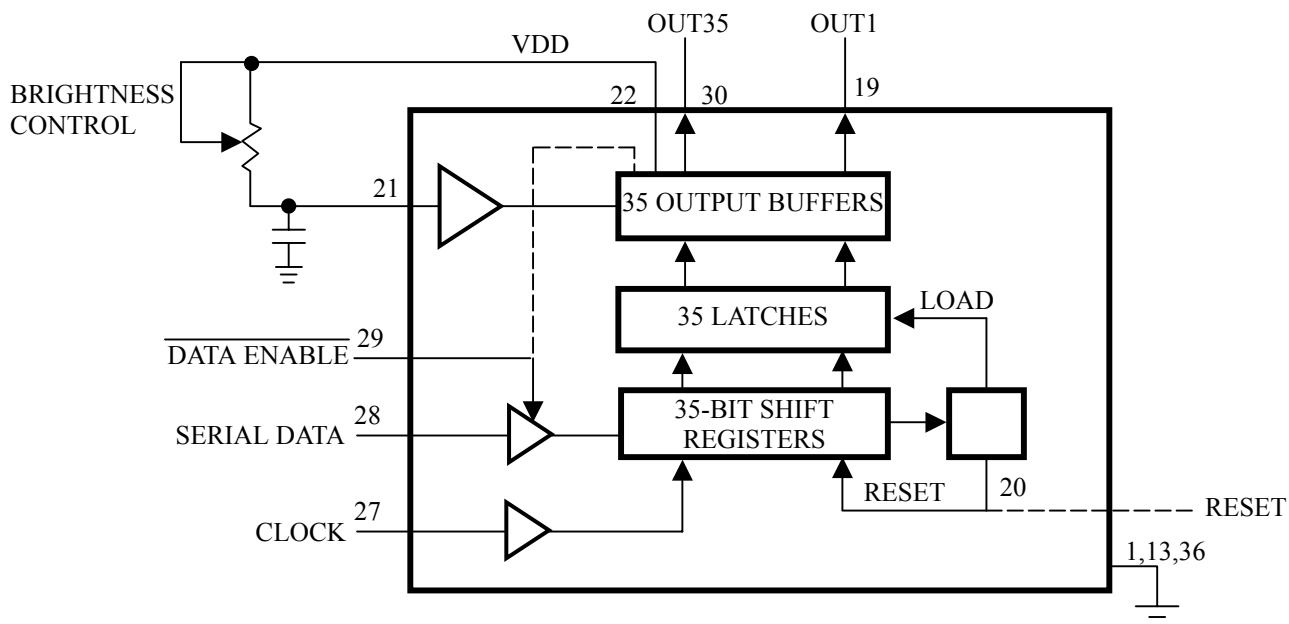

Figure 1

Connection Diagram : SSOP48 Package

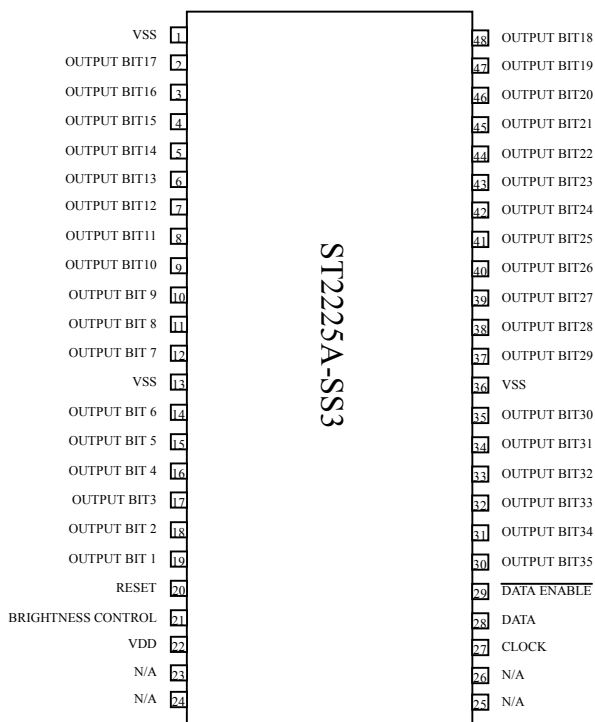
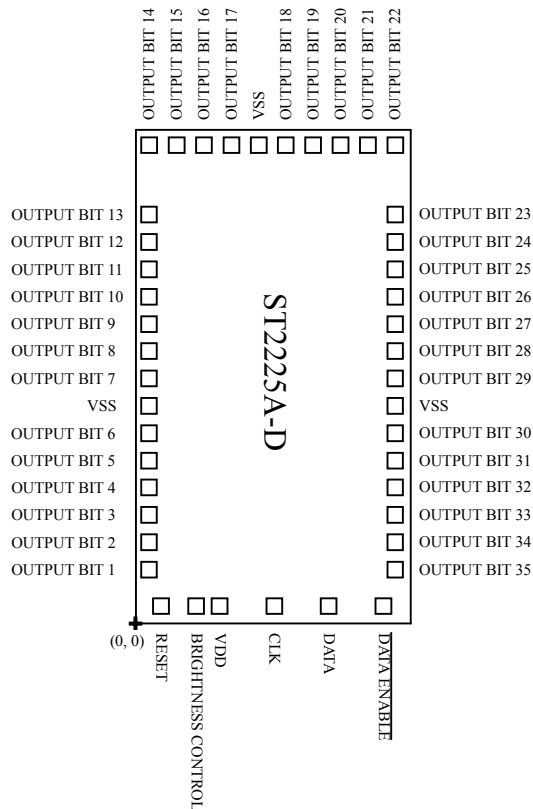

Figure 2

Die Configuration



Die Size: 1449.6um * 2614um

Pad Size: 100um * 100um

Figure 3

* **Note:** SiTI reserves the right to improve the device geometry and manufacturing processes without prior notice. Though these improvements may result in slight geometry changes, they will not affect die electrical characteristics and pad layouts.

Wafer Information

Material : Silicon with P-Substrate

Diameter : 6 inches(≒15cm)

Thickness : 12 mils(≒300um)

Width of scribe line : 100um

Malfunctioned die : Marked with red ink or equivalent marking

Pad Allocation for the Bare Chip, ST2225A-D

PAD Name	Center Coordinate (X,Y) um		PAD Name	Center Coordinate (X,Y) um	
VSS	666.2	2574.7	CLK	744	109.7
OUTPUT17	526.2	2574.7	DATA	1033.2	109.7
OUTPUT16	381.2	2574.7	DATAENZ	1322.4	109.7
OUTPUT15	236.2	2574.7	OUTPUT35	1375.9	295.2
OUTPUT14	91.2	2574.7	OUTPUT34	1375.9	445.2
OUTPUT13	100.1	2225.2	OUTPUT33	1375.9	595.2
OUTPUT12	100.1	2075.2	OUTPUT32	1375.9	745.2
OUTPUT11	100.1	1925.2	OUTPUT31	1375.9	895.2
OUTPUT10	100.1	1775.2	OUTPUT30	1375.9	1045.2
OUTPUT9	100.1	1625.2	VSS	1375.9	1185.2
OUTPUT8	100.1	1475.2	OUTPUT29	1375.9	1325.2
OUTPUT7	100.1	1325.2	OUTPUT28	1375.9	1475.2
VSS	100.1	1185.2	OUTPUT27	1375.9	1625.2
OUTPUT6	100.1	1045.2	OUTPUT26	1375.9	1775.2
OUTPUT5	100.1	895.2	OUTPUT25	1375.9	1925.2
OUTPUT4	100.1	745.2	OUTPUT24	1375.9	2075.2
OUTPUT3	100.1	595.2	OUTPUT23	1375.9	2225.2
OUTPUT2	100.1	446.6	OUTPUT22	1375.9	2574.7
OUTPUT1	100.1	306.6	OUTPUT21	1241.2	2574.7
RESET	168.6	109.7	OUTPUT20	1096.1	2574.7
IBRIGHT	385.7	109.7	OUTPUT19	951.2	2574.7
VDD	520.7	109.7	OUTPUT18	806.2	2574.7



Absolute Maximum Ratings

Voltage (any pin).....	V _{SS} to V _{SS} +12V
Power Dissipation (P _D)	
+25°C	1.52W
+85°C	790mW
Junction Temperature (T _J).....	+150°C
Storage Temperature (T _S).....	-65°C to +150°C
Lead Temperature (soldering, 10 sec.).....	+300°C

Electrical Characteristics

4.5V ≤ V_{DD} ≤ 11V, V_{SS}=0V; T_A=25°C, bold values indicate -40°C ≤ T_A ≤ +85°C ; unless noted

Symbol	Parameter	Condition	Min	Typ	Max	Units
I _{DD}	Power Supply Current	-25°C to +85°C, excluding output loads			5	m A
		-40°C to +85°C, excluding output loads			6	m A
V _{IL}	Low-level Data Input Voltage	logic-0 level, ±10 μA input bias	-0.3		0.8	V
V _{IH}	High-level Data Input Voltage	logic-1 level, 4.75V ≤ V _{DD} ≤ 5.25V	2.2		V _{DD}	V
		logic-1 level, V _{DD} > 5.25V	V _{DD} -2		V _{DD}	V
I _{BC}	Brightness Control Input Current	Note 2	0		0.75	m A
I _{OUT OFF}	Output Sink Current When "OFF"	Segment off, V _{OUT} =3.0V			10	μ A
I _{OUT ON}	Output Sink Current When "ON"	Segment on, V _{OUT} =1.0V, Note 3				
		Brightness input = 0 μA	0		10	μ A
		Brightness input = 100 μA	2.0	2.7	4	m A
		Brightness input = 750 μA	15	20	25	m A
V _{BC}	Brightness Control Input Voltage	Input Current = 750 μA	3.0		4.3	V
R _{MATCH}	Output Matching	Note 1			±20	%
f _C	Clock Input Frequency	Notes 4, 5			500	kHz
t _H	Clock Input High Time	Notes 4, 5	950			ns
t _L	Clock Input Low Time	Notes 4, 5	950			ns
t _{DS}	Data Input Setup Time		300			ns
t _{DH}	Data Input Hold Time		300			ns
t _{DES}	Data Enable Input Setup Time		100			ns

Note 1: Output matching is calculated as the percent variation (I_{MAX} + I_{MIN}) / 2

Note 2: With a fixed resistor on the brightness input pin, some variation in brightness will occur among devices.

Note 3: V_{OUT} should be so regulated that power dissipation of the chip will not exceed its limit.

Note 4: AC input waveform specification for test purpose: t_R ≤ 20ns, t_F ≤ 20ns, t=500kHz, 50%±10% duty cycle.

Note 5: Clock input rise and fall times must not exceed 300ns.

Operating Ratings

Supply Voltage ($V_{DD} - V_{SS}$)+4.75V to 11V
Ambient Temperature Range (T_A).....-40°C to +85°C

Functional Description

The ST2225A display driver can drive either 4- or 5-digit alphanumeric LED displays. One of its advantages is its minimal interface requirement with the display or data source.

Data transfer is accomplished by sending clock and serial data signals, without any need of an external load signal. This method provides a non-multiplexed, direct drive to the LED display. The data transfer format uses a leading “1” followed by 35 data bits. These 35 data bits are latched after the 36th has been transferred. In this way, data output (refers to the currently displayed characters) changes only if the serial data bits differ from those previously transferred.

Display brightness is controlled by the output current for LED displays. A 1nF capacitor should be connected to brightness control pin to prevent oscillations.

Figure 1 shows the block diagram of this driver. The output current is set via an external variable resistor, and is typically 27 times greater than the current in brightness control pin.

Input data format, as in Figure 4, shows a leading “1” followed by 35 data bits. When the 36th is transferred, a LOAD signal is generated synchronously with the clock high state, thus, the 35 bits of data are loaded into the latches. The low state of the clock is used to generate a RESET signal to clear all shift registers for the next set of data. To allow continuous operation, all shift registers are static master-slaves, with no clear for the master portion of the first register.

Note that a complete set of 36 clocks must be sent in order to clear the shift registers. When ST2225A is powered ON, reset signal is generated internally to reset all registers and all latches. Then, the START bit and the first clock make it return to its normal operation.

Figure 2 shows the pin-out of the package for ST2225A. Figure 3 shows the pad-assignment of the bare chip for ST2225A. The timing relationships between data, clock and DATA ENABLE is shown in Figure 4, with maximum clock frequency of 0.5 MHz assumed.

When this driver is used for applications with lesser number of outputs, the current per output can be increased, or the part can be operated at higher than 1V (Vout). The following equation can be used for calculations.

$$T_j = (V_{out}) (I_{LED}) (\text{NO. of segments}) (82^\circ\text{C/W}) + T_A$$

Where:

T_j = junction temperature (150°C max)

V_{out} = the voltage at the LED driver outputs

I_{LED} = the LED current

82°C/W = thermal resistance of the package

T_A = ambient temperature

The above equation was used to plot Figure 6-8.

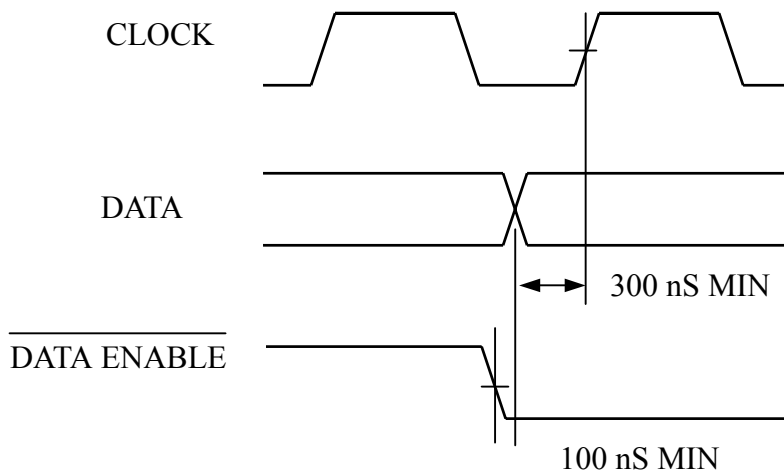

Figure 4

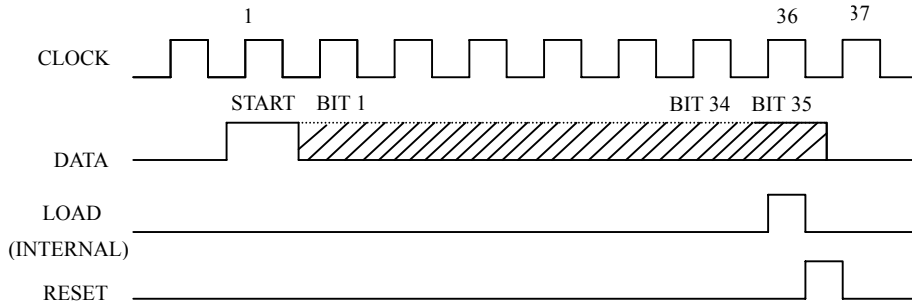

Figure 5 Input Data Format

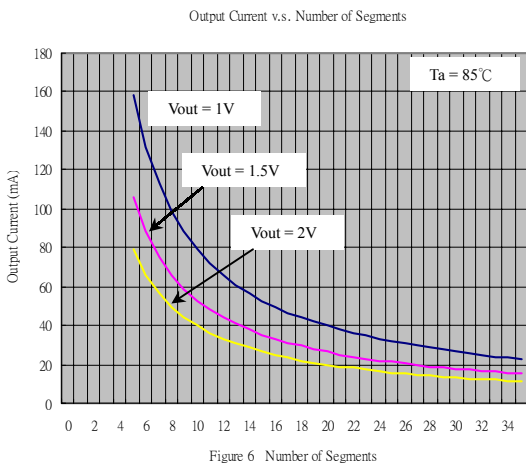

Figure 6 Number of Segments

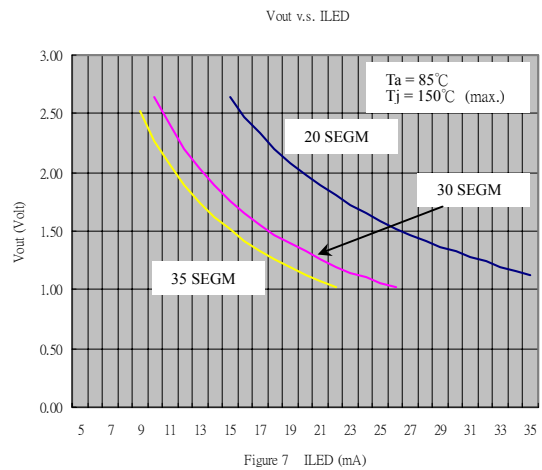

Figure 7 ILED (mA)

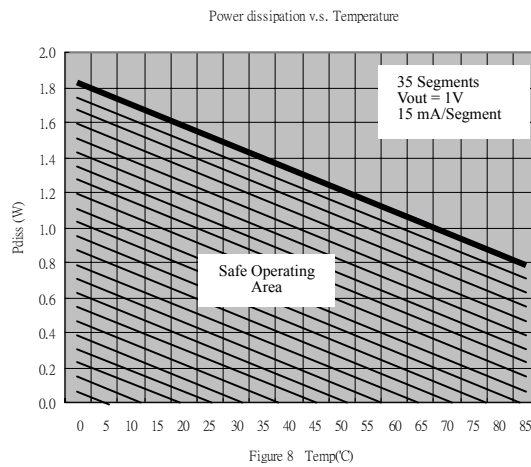

Figure 8 Temp(°C)

Typical Applications

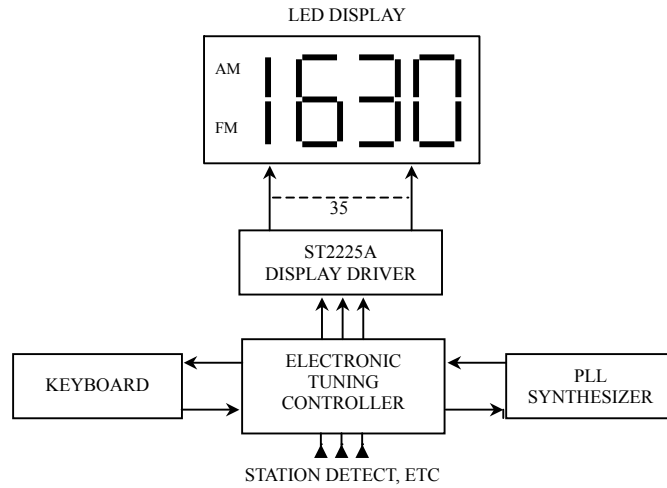

Figure 9 Basic Electronically Tuned Radio System

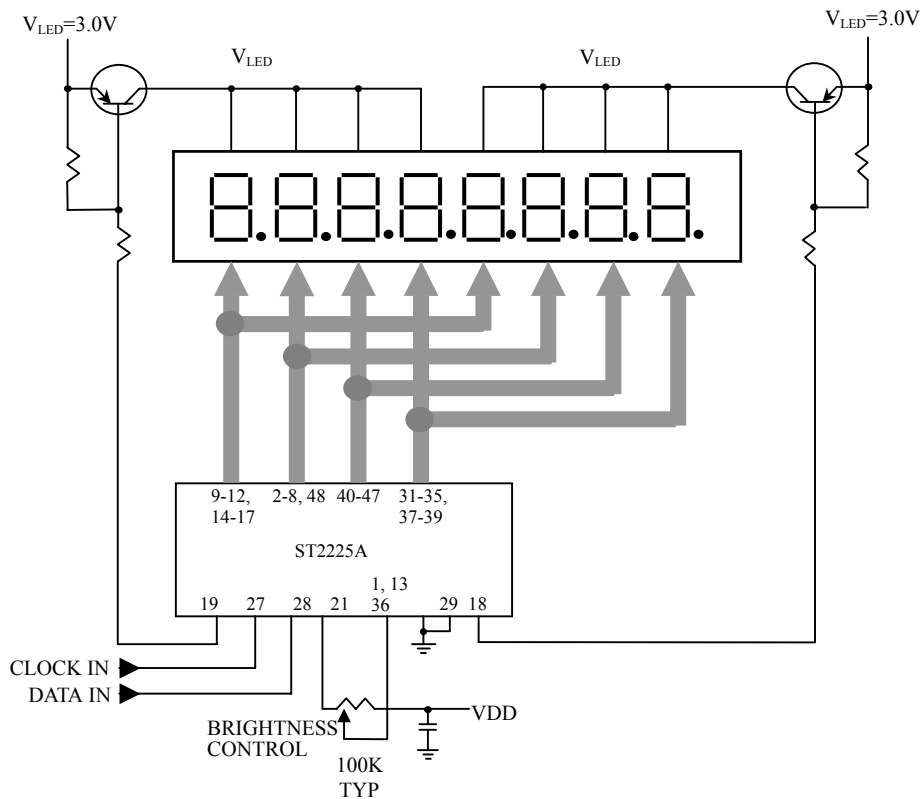
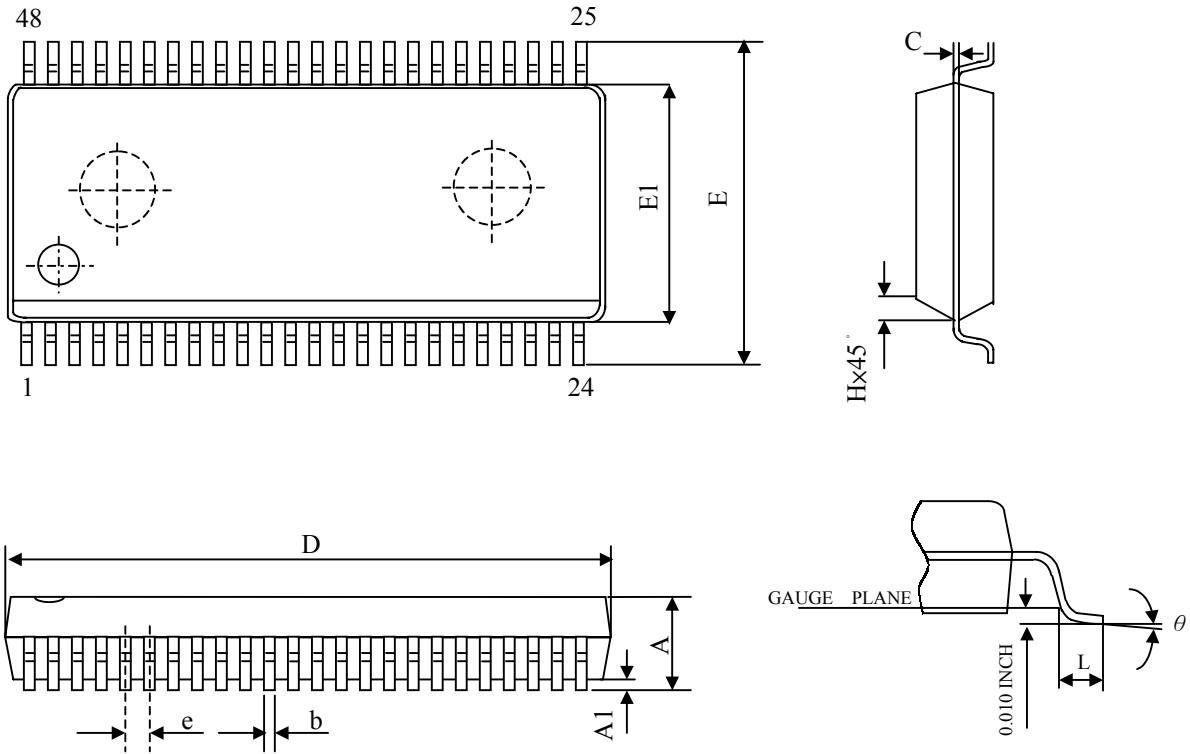

Figure 10 Duplexing 8 Digits with One ST2225A



Package Outline (SSOP48) for ST2225A-SS3



SYMBOL	DIMENSION IN MM			DIMENSION IN INCH		
	MIN.	NOM.	MAX.	MIN.	NOM.	MAX.
A	2.413	2.591	2.794	0.095	0.102	0.110
A1	0.203	0.305	0.406	0.008	0.012	0.016
b	0.203		0.343	0.008		0.0135
C	0.127		0.254	0.005		0.010
e	0.635 BASIC			0.025 BASIC		
E	10.033		10.668	0.395		0.420
E1	7.391	7.493	7.595	0.291	0.295	0.299
H	0.381		0.635	0.015		0.025
L	0.508		1.016	0.020		0.040
θ	0		8	0		8

N	D DIMENSION (IN INCH)			JEDEC
48	0.620	0.625	0.630	MO-118(AA)



The products listed herein are designed for ordinary electronic applications, such as electrical appliances, audio-visual equipment, communications devices and so on. Hence, it is advisable that the devices should not be used in medical instruments, surgical implants, aerospace machinery, nuclear power control systems, disaster/crime-prevention equipment and the like. Misusing those products may directly or indirectly endanger human life, or cause injury and property loss.

Silicon Touch Technology, Inc. will not take any responsibilities regarding the misuse of the products mentioned above. Anyone who purchases any products described herein with the above-mentioned intention or with such misused applications should accept full responsibility and indemnify. Silicon Touch Technology, Inc. and its distributors and all their officers and employees shall defend jointly and severally against any and all claims and litigation and all damages, cost and expenses associated with such intention and manipulation.