

- Preliminary Specification
- Final Specification

Module	8.4 Inch Color TFT-LCD
Model Name	G084XAN01.0 (97D08G08.000)

Customer	Date
_____	_____
Checked & Approved by	
_____	_____

Approved by	Date
_____	_____
Prepared by	
Danny Liao	2022/08/05
General Display Business Unit / AUO Display Plus Corporation	

ADP Confidential for Promate Use Only

Contents

1. Operating Precautions.....	5
2. General Description.....	6
2.1 Display Characteristics	6
2.2 Optical Characteristics	7
3. Functional Block Diagram.....	9
4. Absolute Maximum Ratings.....	10
4.1 Absolute Ratings	10
4.2 Absolute Ratings of Environment	10
5. Electrical Characteristics	11
5.1 TFT-LCD Driving	11
5.2 Backlight Unit Driving.....	14
6. Signal Characteristic	15
6.1 Pixel Format Image	15
6.2 Scanning Direction	15
6.3 TFT-LCD Interface Signal Description	16
6.4 Interface Timing.....	17
7. Connector & Pin Assignment	20
7.1 TFT- LCD Signal (CN1): LCD Connector	20
7.2 LED Backlight Unit (CN2): Backlight Connector	21
7.3 PIN 1 definition of CN1 and CN2	21
8. Reliability Test Criteria	22
9. Mechanical Characteristics.....	23
10. Label and Packaging	25
10.1 Shipping Label (on the rear side of TFT-LCD display).....	25
10.2 Carton Package	25
11 Safety	26
11.1 Keen Edge Requirements.....	26
11.2 Materials.....	26
11.3 Capacitors	26
11.4 National Test Lab Requirement	26

Record of Revision

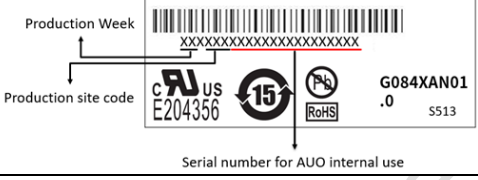
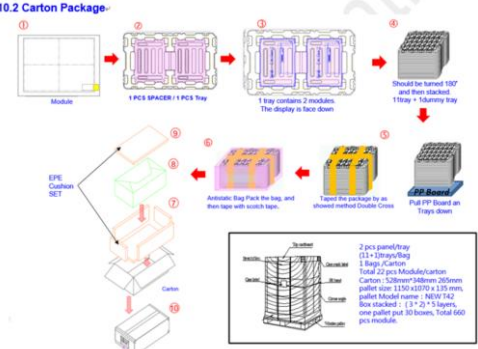
Version and Date	Page	Old description	New Description	Remark																																																																																																																																																																																																																		
0.0 2022/01/29	All	First edition																																																																																																																																																																																																																				
0.1 2022/04/29	24	10.1 Shipping Label (on the rear side of TFT-LCD display) 	10.1 Shipping Label (on the rear side of TFT-LCD display) 																																																																																																																																																																																																																			
	24	10.2 Carton Package Max. capacity: TBD pieces TFT-LCD module per carton Max. weight: TBD kg per carton Outside dimension of carton: TBD	10.2 Carton Package 																																																																																																																																																																																																																			
0.2 2022/08/05	6	2.1 Display Characteristics The following items are characteristics summary under 25°C condition. (Room Temperature) <table border="1" style="width: 100%; border-collapse: collapse;"> <thead> <tr> <th>Items</th> <th>Unit</th> <th>Specifications</th> </tr> </thead> <tbody> <tr><td>Screen Diagonal</td><td>inch</td><td>8.4</td></tr> <tr><td>Active Area</td><td>mm</td><td>170.496(H) x 127.872(V)</td></tr> <tr><td>Pixels H x V</td><td>-</td><td>1024 x 3(RGB) x 768</td></tr> <tr><td>Pixel Pitch</td><td>mm</td><td>0.166 x 0.166</td></tr> <tr><td>Pixel Arrangement</td><td>-</td><td>R, G, B, Stripe</td></tr> <tr><td>Display Mode</td><td>-</td><td>AHVA, Normally Black</td></tr> <tr><td>Nominal Input Voltage VDD</td><td>Volt</td><td>3.3 typ.</td></tr> <tr><td>Typical Power Consumption</td><td>Watt</td><td>TBD</td></tr> <tr><td>Weight</td><td>Grams</td><td>TBD</td></tr> <tr><td>Physical Size</td><td>mm</td><td>199.5(H) x 149.0(V) x 9.05(D) (typ.)</td></tr> <tr><td>Electrical Interface</td><td>-</td><td>LVDS</td></tr> <tr><td>Surface Treatment</td><td>-</td><td>AG</td></tr> <tr><td>Support Color</td><td>-</td><td>16.7M colors</td></tr> <tr><td>Temperature Range</td><td>-</td><td>-</td></tr> <tr><td> Operating</td><td>°C</td><td>-30 to +85</td></tr> <tr><td> Storage (Non-Operating)</td><td>°C</td><td>-30 to +85</td></tr> <tr><td>RoHS Compliance</td><td>-</td><td>RoHS Compliance</td></tr> </tbody> </table>	Items	Unit	Specifications	Screen Diagonal	inch	8.4	Active Area	mm	170.496(H) x 127.872(V)	Pixels H x V	-	1024 x 3(RGB) x 768	Pixel Pitch	mm	0.166 x 0.166	Pixel Arrangement	-	R, G, B, Stripe	Display Mode	-	AHVA, Normally Black	Nominal Input Voltage VDD	Volt	3.3 typ.	Typical Power Consumption	Watt	TBD	Weight	Grams	TBD	Physical Size	mm	199.5(H) x 149.0(V) x 9.05(D) (typ.)	Electrical Interface	-	LVDS	Surface Treatment	-	AG	Support Color	-	16.7M colors	Temperature Range	-	-	Operating	°C	-30 to +85	Storage (Non-Operating)	°C	-30 to +85	RoHS Compliance	-	RoHS Compliance	2.1 Display Characteristics The following items are characteristics summary under 25°C condition. (Room Temperature) <table border="1" style="width: 100%; border-collapse: collapse;"> <thead> <tr> <th>Items</th> <th>Unit</th> <th>Specifications</th> </tr> </thead> <tbody> <tr><td>Screen Diagonal</td><td>inch</td><td>8.4</td></tr> <tr><td>Active Area</td><td>mm</td><td>170.496(H) x 127.872(V)</td></tr> <tr><td>Pixels H x V</td><td>-</td><td>1024 x 3(RGB) x 768</td></tr> <tr><td>Pixel Pitch</td><td>mm</td><td>0.166 x 0.166</td></tr> <tr><td>Pixel Arrangement</td><td>-</td><td>R, G, B, Stripe</td></tr> <tr><td>Display Mode</td><td>-</td><td>AHVA, Normally Black</td></tr> <tr><td>Nominal Input Voltage VDD</td><td>Volt</td><td>3.3 typ.</td></tr> <tr><td>Typical Power Consumption</td><td>Watt</td><td>5.3</td></tr> <tr><td>Weight</td><td>Grams</td><td>282 (typ.), 310(max)</td></tr> <tr><td>Physical Size</td><td>mm</td><td>199.5(H) x 149.0(V) x 9.05(D) (typ.)</td></tr> <tr><td>Electrical Interface</td><td>-</td><td>LVDS</td></tr> <tr><td>Surface Treatment</td><td>-</td><td>AG</td></tr> <tr><td>Support Color</td><td>-</td><td>16.7M colors</td></tr> <tr><td>Temperature Range</td><td>-</td><td>-</td></tr> <tr><td> Operating</td><td>°C</td><td>-30 to +85</td></tr> <tr><td> Storage (Non-Operating)</td><td>°C</td><td>-30 to +85</td></tr> <tr><td>RoHS Compliance</td><td>-</td><td>RoHS Compliance</td></tr> </tbody> </table>	Items	Unit	Specifications	Screen Diagonal	inch	8.4	Active Area	mm	170.496(H) x 127.872(V)	Pixels H x V	-	1024 x 3(RGB) x 768	Pixel Pitch	mm	0.166 x 0.166	Pixel Arrangement	-	R, G, B, Stripe	Display Mode	-	AHVA, Normally Black	Nominal Input Voltage VDD	Volt	3.3 typ.	Typical Power Consumption	Watt	5.3	Weight	Grams	282 (typ.), 310(max)	Physical Size	mm	199.5(H) x 149.0(V) x 9.05(D) (typ.)	Electrical Interface	-	LVDS	Surface Treatment	-	AG	Support Color	-	16.7M colors	Temperature Range	-	-	Operating	°C	-30 to +85	Storage (Non-Operating)	°C	-30 to +85	RoHS Compliance	-	RoHS Compliance																																																																																																							
Items	Unit	Specifications																																																																																																																																																																																																																				
Screen Diagonal	inch	8.4																																																																																																																																																																																																																				
Active Area	mm	170.496(H) x 127.872(V)																																																																																																																																																																																																																				
Pixels H x V	-	1024 x 3(RGB) x 768																																																																																																																																																																																																																				
Pixel Pitch	mm	0.166 x 0.166																																																																																																																																																																																																																				
Pixel Arrangement	-	R, G, B, Stripe																																																																																																																																																																																																																				
Display Mode	-	AHVA, Normally Black																																																																																																																																																																																																																				
Nominal Input Voltage VDD	Volt	3.3 typ.																																																																																																																																																																																																																				
Typical Power Consumption	Watt	TBD																																																																																																																																																																																																																				
Weight	Grams	TBD																																																																																																																																																																																																																				
Physical Size	mm	199.5(H) x 149.0(V) x 9.05(D) (typ.)																																																																																																																																																																																																																				
Electrical Interface	-	LVDS																																																																																																																																																																																																																				
Surface Treatment	-	AG																																																																																																																																																																																																																				
Support Color	-	16.7M colors																																																																																																																																																																																																																				
Temperature Range	-	-																																																																																																																																																																																																																				
Operating	°C	-30 to +85																																																																																																																																																																																																																				
Storage (Non-Operating)	°C	-30 to +85																																																																																																																																																																																																																				
RoHS Compliance	-	RoHS Compliance																																																																																																																																																																																																																				
Items	Unit	Specifications																																																																																																																																																																																																																				
Screen Diagonal	inch	8.4																																																																																																																																																																																																																				
Active Area	mm	170.496(H) x 127.872(V)																																																																																																																																																																																																																				
Pixels H x V	-	1024 x 3(RGB) x 768																																																																																																																																																																																																																				
Pixel Pitch	mm	0.166 x 0.166																																																																																																																																																																																																																				
Pixel Arrangement	-	R, G, B, Stripe																																																																																																																																																																																																																				
Display Mode	-	AHVA, Normally Black																																																																																																																																																																																																																				
Nominal Input Voltage VDD	Volt	3.3 typ.																																																																																																																																																																																																																				
Typical Power Consumption	Watt	5.3																																																																																																																																																																																																																				
Weight	Grams	282 (typ.), 310(max)																																																																																																																																																																																																																				
Physical Size	mm	199.5(H) x 149.0(V) x 9.05(D) (typ.)																																																																																																																																																																																																																				
Electrical Interface	-	LVDS																																																																																																																																																																																																																				
Surface Treatment	-	AG																																																																																																																																																																																																																				
Support Color	-	16.7M colors																																																																																																																																																																																																																				
Temperature Range	-	-																																																																																																																																																																																																																				
Operating	°C	-30 to +85																																																																																																																																																																																																																				
Storage (Non-Operating)	°C	-30 to +85																																																																																																																																																																																																																				
RoHS Compliance	-	RoHS Compliance																																																																																																																																																																																																																				
	7	2.2 Optical Characteristics The optical characteristics are measured under stable conditions at 25°C (Room Temperature) <table border="1" style="width: 100%; border-collapse: collapse;"> <thead> <tr> <th>Item</th> <th>Unit</th> <th>Conditions</th> <th>Min.</th> <th>Typ.</th> <th>Max.</th> <th>Remark</th> </tr> </thead> <tbody> <tr><td>White Luminance</td><td>cd/m²</td><td>V_{LED} = 12V, D_{view} = 100% (center point)</td><td>450</td><td>500</td><td>-</td><td>Note 1-</td></tr> <tr><td>Uniformity</td><td>%</td><td>5 Points</td><td>75</td><td>80</td><td>-</td><td>Note 1, 2, 3-</td></tr> <tr><td>Contrast Ratio</td><td>-</td><td>-</td><td>800</td><td>-</td><td>-</td><td>Note 4-</td></tr> <tr><td rowspan="3">Response Time</td><td rowspan="3">msec</td><td>Rising</td><td>-</td><td>-</td><td>-</td><td rowspan="3">Note 5-</td></tr> <tr><td>Falling</td><td>-</td><td>-</td><td>-</td></tr> <tr><td>Rising + Falling</td><td>-</td><td>-</td><td>30</td></tr> <tr><td rowspan="2">Viewing Angle</td><td>degree</td><td>Horizontal (Right) (Left)</td><td>-</td><td>89</td><td>-</td><td rowspan="2">Note 6-</td></tr> <tr><td>degree</td><td>Vertical (Upper) (Lower)</td><td>-</td><td>89</td><td>-</td></tr> <tr><td rowspan="6">Color / Chromaticity Coordinates (CIE 1931)</td><td>-</td><td>White x₁</td><td>-</td><td>0.31</td><td>-</td><td>-</td></tr> <tr><td>-</td><td>White y₁</td><td>-</td><td>0.33</td><td>-</td><td>-</td></tr> <tr><td>-</td><td>Red x₁</td><td>-</td><td>TBD</td><td>-</td><td>-</td></tr> <tr><td>-</td><td>Red y₁</td><td>-</td><td>TBD</td><td>-</td><td>-</td></tr> <tr><td>-</td><td>Green x₁</td><td>-</td><td>TBD</td><td>-</td><td>-</td></tr> <tr><td>-</td><td>Green y₁</td><td>-</td><td>TBD</td><td>-</td><td>-</td></tr> <tr><td>Color Gamut</td><td>%</td><td>-</td><td>70</td><td>-</td><td>-</td><td>-</td></tr> </tbody> </table>	Item	Unit	Conditions	Min.	Typ.	Max.	Remark	White Luminance	cd/m ²	V _{LED} = 12V, D _{view} = 100% (center point)	450	500	-	Note 1-	Uniformity	%	5 Points	75	80	-	Note 1, 2, 3-	Contrast Ratio	-	-	800	-	-	Note 4-	Response Time	msec	Rising	-	-	-	Note 5-	Falling	-	-	-	Rising + Falling	-	-	30	Viewing Angle	degree	Horizontal (Right) (Left)	-	89	-	Note 6-	degree	Vertical (Upper) (Lower)	-	89	-	Color / Chromaticity Coordinates (CIE 1931)	-	White x ₁	-	0.31	-	-	-	White y ₁	-	0.33	-	-	-	Red x ₁	-	TBD	-	-	-	Red y ₁	-	TBD	-	-	-	Green x ₁	-	TBD	-	-	-	Green y ₁	-	TBD	-	-	Color Gamut	%	-	70	-	-	-	2.2 Optical Characteristics The optical characteristics are measured under stable conditions at 25°C (Room Temperature) <table border="1" style="width: 100%; border-collapse: collapse;"> <thead> <tr> <th>Item</th> <th>Unit</th> <th>Conditions</th> <th>Min.</th> <th>Typ.</th> <th>Max.</th> <th>Remark</th> </tr> </thead> <tbody> <tr><td>White Luminance</td><td>cd/m²</td><td>V_{LED} = 12V, D_{view} = 100% (center point)</td><td>550</td><td>700</td><td>-</td><td>Note 1-</td></tr> <tr><td>Uniformity</td><td>%</td><td>5 Points</td><td>75</td><td>80</td><td>-</td><td>Note 1, 2, 3-</td></tr> <tr><td>Contrast Ratio</td><td>-</td><td>-</td><td>800</td><td>-</td><td>-</td><td>Note 4-</td></tr> <tr><td rowspan="3">Response Time</td><td rowspan="3">msec</td><td>Rising</td><td>-</td><td>15</td><td>20</td><td rowspan="3">Note 5-</td></tr> <tr><td>Falling</td><td>-</td><td>10</td><td>15</td></tr> <tr><td>Rising + Falling</td><td>-</td><td>25</td><td>35</td></tr> <tr><td rowspan="2">Viewing Angle</td><td>degree</td><td>Horizontal (Right) (Left)</td><td>85</td><td>89</td><td>-</td><td rowspan="2">Note 6-</td></tr> <tr><td>degree</td><td>Vertical (Upper) (Lower)</td><td>85</td><td>89</td><td>-</td></tr> <tr><td rowspan="6">Color / Chromaticity Coordinates (CIE 1931)</td><td>-</td><td>White x₁</td><td>0.260</td><td>0.310</td><td>0.360</td><td>-</td></tr> <tr><td>-</td><td>White y₁</td><td>0.280</td><td>0.330</td><td>0.380</td><td>-</td></tr> <tr><td>-</td><td>Red x₁</td><td>0.593</td><td>0.643</td><td>0.693</td><td>-</td></tr> <tr><td>-</td><td>Red y₁</td><td>0.285</td><td>0.335</td><td>0.385</td><td>-</td></tr> <tr><td>-</td><td>Green x₁</td><td>0.254</td><td>0.304</td><td>0.354</td><td>-</td></tr> <tr><td>-</td><td>Green y₁</td><td>0.567</td><td>0.617</td><td>0.667</td><td>-</td></tr> <tr><td rowspan="2">Color Gamut</td><td rowspan="2">%</td><td>Blue x₁</td><td>0.102</td><td>0.152</td><td>0.202</td><td>-</td></tr> <tr><td>Blue y₁</td><td>0.005</td><td>0.055</td><td>0.105</td><td>-</td></tr> <tr><td>Color Gamut</td><td>%</td><td>-</td><td>70</td><td>-</td><td>-</td><td>-</td></tr> </tbody> </table>	Item	Unit	Conditions	Min.	Typ.	Max.	Remark	White Luminance	cd/m ²	V _{LED} = 12V, D _{view} = 100% (center point)	550	700	-	Note 1-	Uniformity	%	5 Points	75	80	-	Note 1, 2, 3-	Contrast Ratio	-	-	800	-	-	Note 4-	Response Time	msec	Rising	-	15	20	Note 5-	Falling	-	10	15	Rising + Falling	-	25	35	Viewing Angle	degree	Horizontal (Right) (Left)	85	89	-	Note 6-	degree	Vertical (Upper) (Lower)	85	89	-	Color / Chromaticity Coordinates (CIE 1931)	-	White x ₁	0.260	0.310	0.360	-	-	White y ₁	0.280	0.330	0.380	-	-	Red x ₁	0.593	0.643	0.693	-	-	Red y ₁	0.285	0.335	0.385	-	-	Green x ₁	0.254	0.304	0.354	-	-	Green y ₁	0.567	0.617	0.667	-	Color Gamut	%	Blue x ₁	0.102	0.152	0.202	-	Blue y ₁	0.005	0.055	0.105	-	Color Gamut	%	-	70	-	-	-	
Item	Unit	Conditions	Min.	Typ.	Max.	Remark																																																																																																																																																																																																																
White Luminance	cd/m ²	V _{LED} = 12V, D _{view} = 100% (center point)	450	500	-	Note 1-																																																																																																																																																																																																																
Uniformity	%	5 Points	75	80	-	Note 1, 2, 3-																																																																																																																																																																																																																
Contrast Ratio	-	-	800	-	-	Note 4-																																																																																																																																																																																																																
Response Time	msec	Rising	-	-	-	Note 5-																																																																																																																																																																																																																
		Falling	-	-	-																																																																																																																																																																																																																	
		Rising + Falling	-	-	30																																																																																																																																																																																																																	
Viewing Angle	degree	Horizontal (Right) (Left)	-	89	-	Note 6-																																																																																																																																																																																																																
	degree	Vertical (Upper) (Lower)	-	89	-																																																																																																																																																																																																																	
Color / Chromaticity Coordinates (CIE 1931)	-	White x ₁	-	0.31	-	-																																																																																																																																																																																																																
	-	White y ₁	-	0.33	-	-																																																																																																																																																																																																																
	-	Red x ₁	-	TBD	-	-																																																																																																																																																																																																																
	-	Red y ₁	-	TBD	-	-																																																																																																																																																																																																																
	-	Green x ₁	-	TBD	-	-																																																																																																																																																																																																																
	-	Green y ₁	-	TBD	-	-																																																																																																																																																																																																																
Color Gamut	%	-	70	-	-	-																																																																																																																																																																																																																
Item	Unit	Conditions	Min.	Typ.	Max.	Remark																																																																																																																																																																																																																
White Luminance	cd/m ²	V _{LED} = 12V, D _{view} = 100% (center point)	550	700	-	Note 1-																																																																																																																																																																																																																
Uniformity	%	5 Points	75	80	-	Note 1, 2, 3-																																																																																																																																																																																																																
Contrast Ratio	-	-	800	-	-	Note 4-																																																																																																																																																																																																																
Response Time	msec	Rising	-	15	20	Note 5-																																																																																																																																																																																																																
		Falling	-	10	15																																																																																																																																																																																																																	
		Rising + Falling	-	25	35																																																																																																																																																																																																																	
Viewing Angle	degree	Horizontal (Right) (Left)	85	89	-	Note 6-																																																																																																																																																																																																																
	degree	Vertical (Upper) (Lower)	85	89	-																																																																																																																																																																																																																	
Color / Chromaticity Coordinates (CIE 1931)	-	White x ₁	0.260	0.310	0.360	-																																																																																																																																																																																																																
	-	White y ₁	0.280	0.330	0.380	-																																																																																																																																																																																																																
	-	Red x ₁	0.593	0.643	0.693	-																																																																																																																																																																																																																
	-	Red y ₁	0.285	0.335	0.385	-																																																																																																																																																																																																																
	-	Green x ₁	0.254	0.304	0.354	-																																																																																																																																																																																																																
	-	Green y ₁	0.567	0.617	0.667	-																																																																																																																																																																																																																
Color Gamut	%	Blue x ₁	0.102	0.152	0.202	-																																																																																																																																																																																																																
		Blue y ₁	0.005	0.055	0.105	-																																																																																																																																																																																																																
Color Gamut	%	-	70	-	-	-																																																																																																																																																																																																																
	11	*5.1.1 Power Specification <table border="1" style="width: 100%; border-collapse: collapse;"> <thead> <tr> <th>Symbol</th> <th>Parameter</th> <th>Min.</th> <th>Typ.</th> <th>Max.</th> <th>Units</th> <th>Remark</th> </tr> </thead> <tbody> <tr><td>VDDA</td><td>LogicLCD Drive Voltage</td><td>3.0</td><td>3.3</td><td>3.6</td><td>Volt</td><td>-</td></tr> <tr><td>IDDA</td><td>VDD Current</td><td>-</td><td>TBD</td><td>TBD</td><td>mA</td><td>All Black Pattern (VDD=3.3V, at 60Hz)</td></tr> <tr><td>Inrush</td><td>LCD Inrush Current</td><td>-</td><td>-</td><td>571</td><td>mA</td><td>Note 1-</td></tr> <tr><td>PDD</td><td>VDD Power</td><td>-</td><td>TBD</td><td>TBD</td><td>Watt</td><td>All Black Pattern (VDD=3.3V, at 60Hz)</td></tr> </tbody> </table>	Symbol	Parameter	Min.	Typ.	Max.	Units	Remark	VDDA	LogicLCD Drive Voltage	3.0	3.3	3.6	Volt	-	IDDA	VDD Current	-	TBD	TBD	mA	All Black Pattern (VDD=3.3V, at 60Hz)	Inrush	LCD Inrush Current	-	-	571	mA	Note 1-	PDD	VDD Power	-	TBD	TBD	Watt	All Black Pattern (VDD=3.3V, at 60Hz)	*5.1.1 Power Specification <table border="1" style="width: 100%; border-collapse: collapse;"> <thead> <tr> <th>Symbol</th> <th>Parameter</th> <th>Min.</th> <th>Typ.</th> <th>Max.</th> <th>Units</th> <th>Remark</th> </tr> </thead> <tbody> <tr><td>VDDA</td><td>LogicLCD Drive Voltage</td><td>3.0</td><td>3.3</td><td>3.6</td><td>Volt</td><td>-</td></tr> <tr><td>IDDA</td><td>VDD Current</td><td>-</td><td>150</td><td>220</td><td>mA</td><td>All Black Pattern (VDD=3.3V, at 60Hz)</td></tr> <tr><td>Inrush</td><td>LCD Inrush Current</td><td>-</td><td>-</td><td>571</td><td>mA</td><td>Note 1-</td></tr> <tr><td>PDD</td><td>VDD Power</td><td>-</td><td>0.5</td><td>0.73</td><td>Watt</td><td>All Black Pattern (VDD=3.3V, at 60Hz)</td></tr> </tbody> </table>	Symbol	Parameter	Min.	Typ.	Max.	Units	Remark	VDDA	LogicLCD Drive Voltage	3.0	3.3	3.6	Volt	-	IDDA	VDD Current	-	150	220	mA	All Black Pattern (VDD=3.3V, at 60Hz)	Inrush	LCD Inrush Current	-	-	571	mA	Note 1-	PDD	VDD Power	-	0.5	0.73	Watt	All Black Pattern (VDD=3.3V, at 60Hz)																																																																																																																																													
Symbol	Parameter	Min.	Typ.	Max.	Units	Remark																																																																																																																																																																																																																
VDDA	LogicLCD Drive Voltage	3.0	3.3	3.6	Volt	-																																																																																																																																																																																																																
IDDA	VDD Current	-	TBD	TBD	mA	All Black Pattern (VDD=3.3V, at 60Hz)																																																																																																																																																																																																																
Inrush	LCD Inrush Current	-	-	571	mA	Note 1-																																																																																																																																																																																																																
PDD	VDD Power	-	TBD	TBD	Watt	All Black Pattern (VDD=3.3V, at 60Hz)																																																																																																																																																																																																																
Symbol	Parameter	Min.	Typ.	Max.	Units	Remark																																																																																																																																																																																																																
VDDA	LogicLCD Drive Voltage	3.0	3.3	3.6	Volt	-																																																																																																																																																																																																																
IDDA	VDD Current	-	150	220	mA	All Black Pattern (VDD=3.3V, at 60Hz)																																																																																																																																																																																																																
Inrush	LCD Inrush Current	-	-	571	mA	Note 1-																																																																																																																																																																																																																
PDD	VDD Power	-	0.5	0.73	Watt	All Black Pattern (VDD=3.3V, at 60Hz)																																																																																																																																																																																																																

14

*** 5.2.1 Parameter guideline for LED-**

Following characteristics are measured under stable condition at 25°C (Room Temperature).¹⁾

Symbol ²⁾	Parameter ³⁾	Min. ⁴⁾	Typ. ⁵⁾	Max. ⁶⁾	Unit ⁷⁾	Remark ⁸⁾
VLED ⁹⁾	Input Voltage ¹⁰⁾	10.8 ¹¹⁾	12 ¹²⁾	13.2 ¹³⁾	Volt ¹⁴⁾	
ILED ¹⁵⁾	Input Current ¹⁶⁾	— ¹⁷⁾	207.2 ¹⁸⁾	— ¹⁹⁾	mA ²⁰⁾	VLED =12V, 100% Dimming ²¹⁾
Irush ²²⁾	Inrush Current ²³⁾	— ²⁴⁾	— ²⁵⁾	1.0 ²⁶⁾	A ²⁷⁾	Note 7 ²⁸⁾
PLED ²⁹⁾	Power Consumption ³⁰⁾	— ³¹⁾	TBD ³²⁾	— ³³⁾	Watt ³⁴⁾	VLED =12V, 100% Dimming ³⁵⁾
FPWM ³⁶⁾	PWM Dimming Frequency ³⁷⁾	200 ³⁸⁾	— ³⁹⁾	20K ⁴⁰⁾	Hz ⁴¹⁾	
Dimming ⁴²⁾	Swing Voltage High ⁴³⁾	3 ⁴⁴⁾	4 ⁴⁵⁾	5 ⁴⁶⁾	Volt ⁴⁷⁾	
	Swing Voltage Low ⁴⁸⁾	0 ⁴⁹⁾	0 ⁵⁰⁾	0.6 ⁵¹⁾	Volt ⁵²⁾	Note 1, 2 ⁵³⁾
DPWM ⁵⁴⁾	Dimming Duty Cycle (FPWM20KHz~5KHz) ⁵⁵⁾	5 ⁵⁶⁾	— ⁵⁷⁾	100 ⁵⁸⁾	% ⁵⁹⁾	
	Dimming Duty Cycle (FPWM5KHz~20KHz) ⁶⁰⁾	15 ⁶¹⁾	— ⁶²⁾	100 ⁶³⁾	% ⁶⁴⁾	
IF ⁶⁵⁾	LED Forward Current ⁶⁶⁾	— ⁶⁷⁾	51.8 ⁶⁸⁾	— ⁶⁹⁾	mA ⁷⁰⁾	Ta = 25°C ⁷¹⁾
Enable ⁷²⁾	On Control Voltage ⁷³⁾	3 ⁷⁴⁾	4 ⁷⁵⁾	5 ⁷⁶⁾	Volt ⁷⁷⁾	Note 3, 4 ⁷⁸⁾
	Off Control Voltage ⁷⁹⁾	0 ⁸⁰⁾	0 ⁸¹⁾	0.6 ⁸²⁾	Volt ⁸³⁾	
Operating Life ⁸⁴⁾		70,000 ⁸⁵⁾	— ⁸⁶⁾	— ⁸⁷⁾	Hrs ⁸⁸⁾	Note 5, 6, 7 ⁸⁹⁾

*** 5.2.1 Parameter guideline for LED-**

Following characteristics are measured under stable condition at 25°C (Room Temperature).¹⁾

Symbol ²⁾	Parameter ³⁾	Min. ⁴⁾	Typ. ⁵⁾	Max. ⁶⁾	Unit ⁷⁾	Remark ⁸⁾
VLED ⁹⁾	Input Voltage ¹⁰⁾	10.8 ¹¹⁾	12 ¹²⁾	13.2 ¹³⁾	Volt ¹⁴⁾	
ILED ¹⁵⁾	Input Current ¹⁶⁾	— ¹⁷⁾	400 ¹⁸⁾	— ¹⁹⁾	mA ²⁰⁾	VLED =12V, 100% Dimming ²¹⁾
Irush ²²⁾	Inrush Current ²³⁾	— ²⁴⁾	— ²⁵⁾	1.0 ²⁶⁾	A ²⁷⁾	Note 7 ²⁸⁾
PLED ²⁹⁾	Power Consumption ³⁰⁾	— ³¹⁾	4.8 ³²⁾	— ³³⁾	Watt ³⁴⁾	VLED =12V, 100% Dimming ³⁵⁾
FPWM ³⁶⁾	PWM Dimming Frequency ³⁷⁾	200 ³⁸⁾	— ³⁹⁾	20K ⁴⁰⁾	Hz ⁴¹⁾	
Dimming ⁴²⁾	Swing Voltage High ⁴³⁾	3 ⁴⁴⁾	4 ⁴⁵⁾	5 ⁴⁶⁾	Volt ⁴⁷⁾	
	Swing Voltage Low ⁴⁸⁾	0 ⁴⁹⁾	0 ⁵⁰⁾	0.6 ⁵¹⁾	Volt ⁵²⁾	Note 1, 2 ⁵³⁾
DPWM ⁵⁴⁾	Dimming Duty Cycle (FPWM20KHz~5KHz) ⁵⁵⁾	5 ⁵⁶⁾	— ⁵⁷⁾	100 ⁵⁸⁾	% ⁵⁹⁾	
	Dimming Duty Cycle (FPWM5KHz~20KHz) ⁶⁰⁾	15 ⁶¹⁾	— ⁶²⁾	100 ⁶³⁾	% ⁶⁴⁾	
IF ⁶⁵⁾	LED Forward Current ⁶⁶⁾	— ⁶⁷⁾	51.8 ⁶⁸⁾	— ⁶⁹⁾	mA ⁷⁰⁾	Ta = 25°C ⁷¹⁾
Enable ⁷²⁾	On Control Voltage ⁷³⁾	3 ⁷⁴⁾	4 ⁷⁵⁾	5 ⁷⁶⁾	Volt ⁷⁷⁾	Note 3, 4 ⁷⁸⁾
	Off Control Voltage ⁷⁹⁾	0 ⁸⁰⁾	0 ⁸¹⁾	0.6 ⁸²⁾	Volt ⁸³⁾	
Operating Life ⁸⁴⁾		70,000 ⁸⁵⁾	— ⁸⁶⁾	— ⁸⁷⁾	Hrs ⁸⁸⁾	Note 5, 6, 7 ⁸⁹⁾

ADP Confidential for Promate Use Only

1. Operating Precautions

- 1) Display area (Polarizer) of TFT-LCD Module is easily to be damaged, please be cautious and not to scratch it.
- 2) Be sure to power off your machine before connecting or disconnecting your signal cable to TFT-LCD Module.
- 3) Wipe off water drop on display area immediately. Long contact with water may cause discoloration or spots.
- 4) When the panel surface is soiled, wipe it with absorbent cotton or soft cloth.
- 5) Display area (Glass) of TFT-LCD Module may be broken or cracked if bump Module against hard object.
- 6) To avoid ESD (Electro Static Discharge) damage, be sure to ground yourself before handling TFT-LCD Module.
- 7) Do not open nor modify the TFT-LCD module assembly.
- 8) Do not press the reflector sheet at the back of the module to any direction.
- 9) In case if TFT-LCD module has to be put back into the packing container slot after it was taken out from the container, do not press the center of the LED Reflector edge. Instead, press at the far ends of the LED Reflector edge softly. Otherwise the TFT-LCD Module may be damaged.
- 10) When inserting or removing of your signal cable to TFT-LCD Module, be sure not to apply abnormal force (rotate, tilt...etc.) to the Connector of the TFT-LCD Module.
- 11) TFT-LCD Module is not allowed to be twisted & bent even force is added on module in a very short time. Please design your display product well to avoid external force applying to module by end-user directly.
- 12) Small amount of materials without flammability grade are used in the TFT-LCD module. The TFT-LCD module should be supplied by power complied with requirements of Limited Power Source (IEC60950 or UL1950), or be applied exemption.
- 13) Severe temperature condition may result in different luminance, response time.
- 14) Continuous operating TFT-LCD Module under high temperature environment may accelerate LED light bar exhaustion and reduce luminance dramatically.
- 15) The data on this specification sheet is applicable when TFT-LCD module is placed in landscape position.
- 16) Continuous displaying fixed pattern may induce image sticking. It's recommended to use screen saver or moving content periodically if fixed pattern is displayed on the screen.

2. General Description

G084XAN01.0 is designed for industrial display applications with XGA(1024 x RGB x 768) resolution and 16.7M colors (RGB 8-bits). It is composed of a TFT-LCD panel, driver ICs, control and power supply circuits board and backlight unit including LED driver circuit.

2.1 Display Characteristics

The following items are characteristics summary under 25°C condition. (Room Temperature)

Items	Unit	Specifications
Screen Diagonal	inch	8.4
Active Area	mm	170.496(H) x 127.872(V)
Pixels H x V		1024 x 3(RGB) x 768
Pixel Pitch	mm	0.166 x 0.166
Pixel Arrangement		R.G.B. Stripe
Display Mode		AHVA, Normally Black
Nominal Input Voltage VDD	Volt	3.3 typ.
Typical Power Consumption	Watt	5.3 (typ.)
Weight	Grams	282 (typ.) , 310(max)
Physical Size	mm	199.5(H) x 149.0(V) x 9.05(D) (typ.)
Electrical Interface		LVDS
Surface Treatment		AG
Support Color		16.7M colors
Temperature Range		
Operating	°C	-30 to +85
Storage (Non-Operating)	°C	-30 to +85
RoHS Compliance		RoHS Compliance

2.2 Optical Characteristics

The optical characteristics are measured under stable conditions at 25°C (Room Temperature).

Item	Unit	Conditions	Min.	Typ.	Max.	Remark
White Luminance	cd/m ²	V _{LED} = 12V, D _{PWM} = 100% (center point)	550	700	-	Note 1
Uniformity	%	5 Points	75	80	-	Note 1, 2, 3
Contrast Ratio			800	-	-	Note 4
Response Time	msec	Rising		15	20	Note 5
	msec	Falling		10	15	
	msec	Rising + Falling		25	35	
Viewing Angle	degree degree	Horizontal (Right) CR = 10 (Left)	85	89		Note 6
	degree degree	Vertical (Upper) CR = 10 (Lower)	85	89		
Color / Chromaticity Coordinates (CIE 1931)		White x	0.260	0.310	0.360	
		White y	0.280	0.330	0.380	
		Red x	0.593	0.643	0.693	
		Red y	0.285	0.335	0.385	
		Green x	0.254	0.304	0.354	
		Green y	0.567	0.617	0.667	
		Blue x	0.102	0.152	0.202	
		Blue y	0.005	0.055	0.105	
Color Gamut	%		70	-	-	

Note 1: Measurement method

Equipment Pattern Generator, Power Supply, Digital Voltmeter, Luminance meter (SR_3 or equivalent)

Aperture 1° with 50cm viewing distance

Test Point Center

Environment < 1 lux

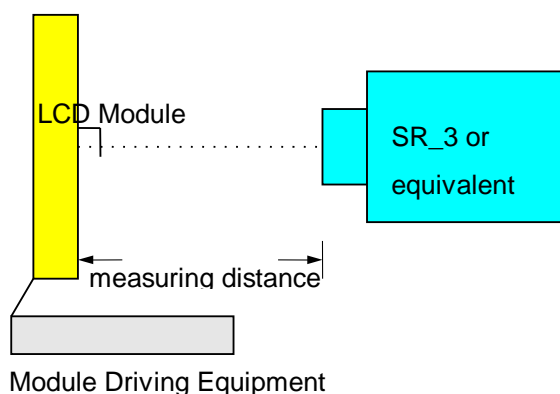

Note 2: Definition of 5 points position (Display active area: 115.2mm(W) x 86.4mm(H))

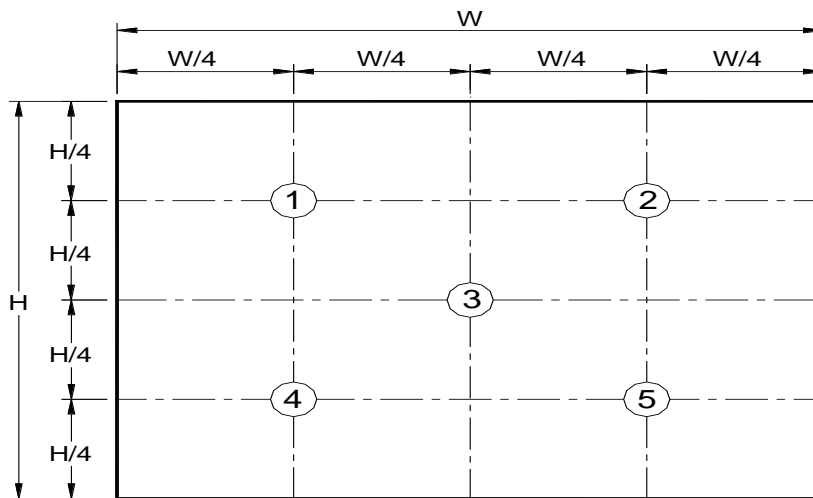

Note 3:

The luminance uniformity of 5 points is defined by dividing the maximum luminance value by the minimum luminance value at full white condition.

$$\delta_{w5} = \frac{\text{Maximum Brightness of five points}}{\text{Minimum Brightness of five points}}$$

Note 4: Definition of contrast ratio (CR):

$$\text{Contrast ratio (CR)} = \frac{\text{Brightness @ "White" state}}{\text{Brightness @ "Black" state}}$$

Note 5: Definition of response time:

The output signals of photo detector are measured when the input signals are changed from "White" to "Black" (falling time) and from "Black" to "White" (rising time), respectively. The response time interval definition is between 10% and 90% of amplitude. Please refer to the figure as below.

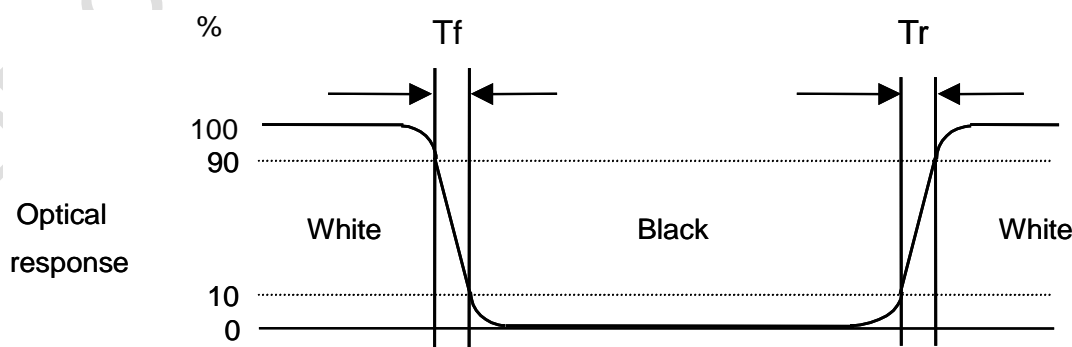

Note 6: Definition of viewing angle

Viewing angle is the measurement of contrast ratio ≥ 10 , at the screen center, over 180° horizontal and 180° vertical range. The 180° horizontal (θ_L, θ_R) and 180° vertical (ϕ_H, ϕ_L) range are illustrated as following figure.

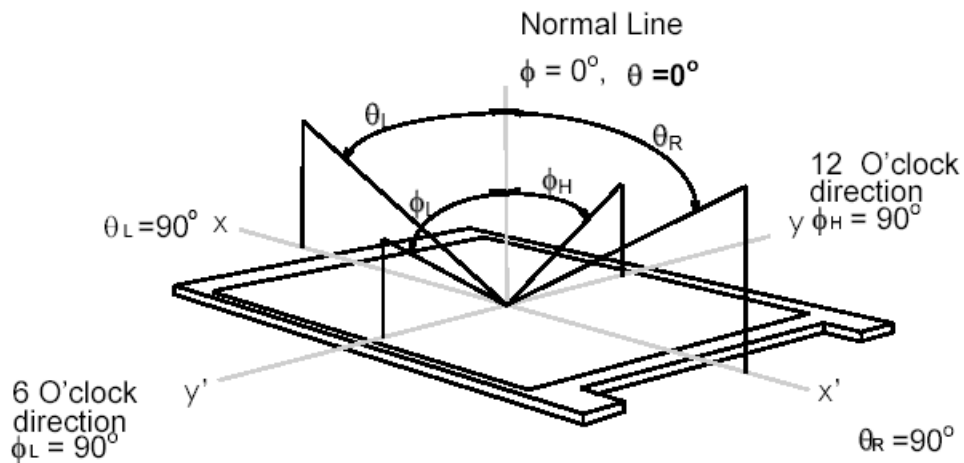

3. Functional Block Diagram

The following diagram shows the functional block of the G084XAN01.0 color TFT/LCD module.

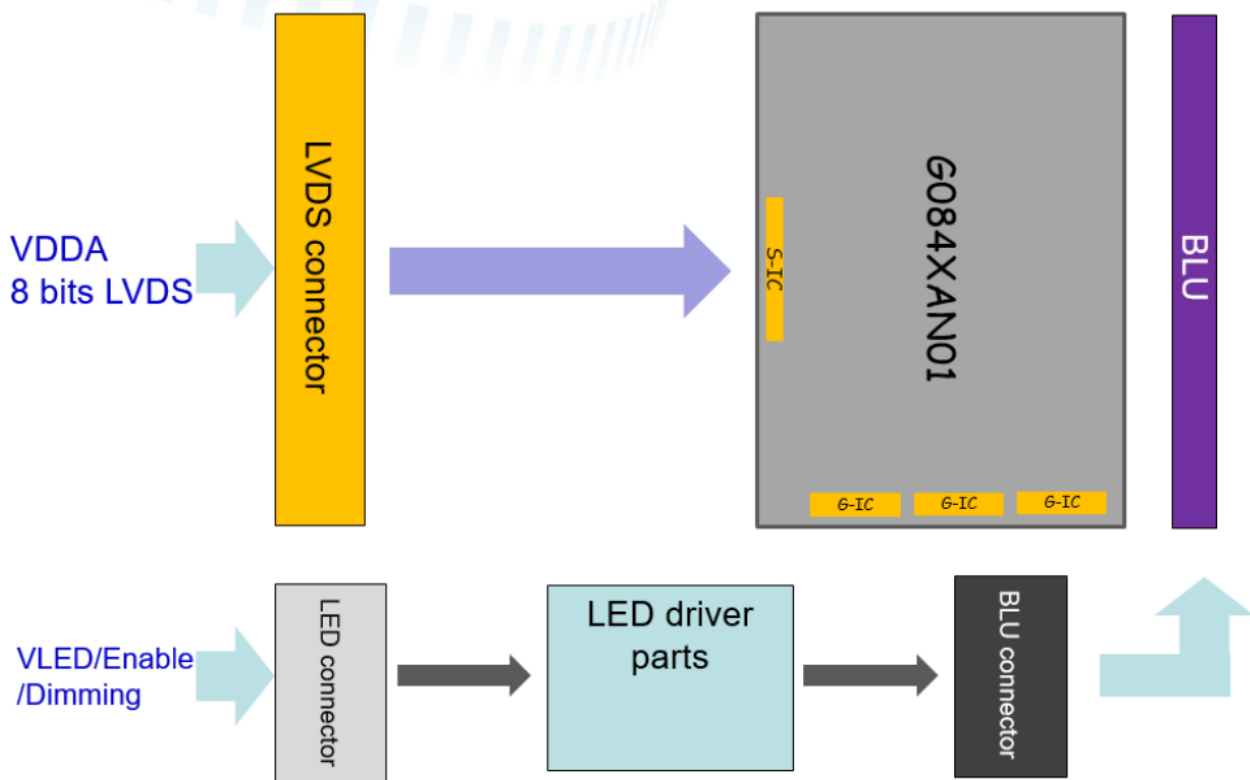

4. Absolute Maximum Ratings

4.1 Absolute Ratings

Item	Symbo	Min	Max	Unit	Remark
Logic/LCD Drive Voltage	VDDA	-0.3	4.0	Volt	Ta= 25°C

4.2 Absolute Ratings of Environment

Item	Symbol	Min	Max	Unit	Remark
Operating Temperature	TOP	-30	+85	°C	Note 1, 2
Operation Humidity	HOP	5	90	%RH	Note 1, 2
Storage Temperature	TST	-30	+85	°C	Note 1
Storage Humidity	HST	5	90	%RH	Note 1

Note 1: Permanent damage to the device may occur if exceed maximum values.

Note 2: Maximum Wet-Bulb should be 39°C and no condensation.

Note 3: Only operation is guaranteed. Optical performance should be evaluated at 25°C only.

Note 4: Operating temperature means “ Front and rear surface” of panel

5. Electrical Characteristics

5.1 TFT-LCD Driving

5.1.1 Power Specification

Symbol	Parameter	Min	Typ	Max	Units	Remark
VDDA	Logic/LCD Drive Voltage	3.0	3.3	3.6	Volt	
IDDA	VDD Current	-	150	220	mA	All Black Pattern (VDD=3.3V, at 60Hz)
Irush	LCD Inrush Current	-	-	571	mA	Note 1
PDD	VDD Power	-	0.5	0.73	Watt	All Black Pattern (VDD=3.3V, at 60Hz)

Note 1: Measurement condition:

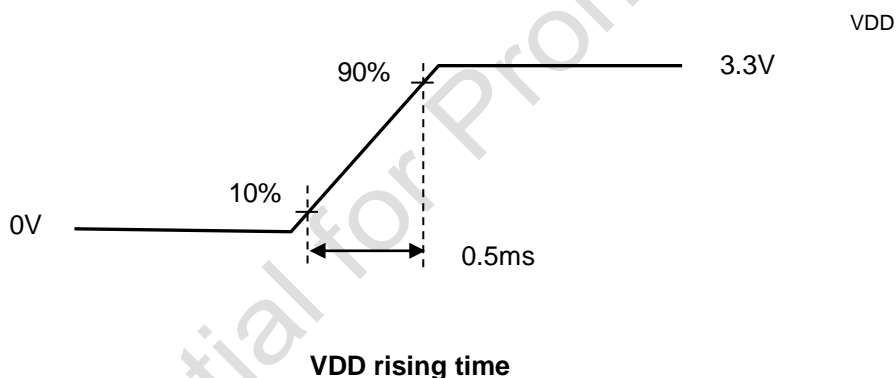

ADP Confidential for Promate Use Only

5.1.2 Signal Electrical Characteristics

Parameter	Symbol	Min	Typ	Max	Unit	Notes
Input high level voltage	VIH	0.7VDDA	-	VDDA	V	GRB LVBIT SHLR UPDN
Input low level voltage	VIL	GND	-	0.3VDDA	V	GRB LVBIT SHLR UPDN
Output high level voltage	VOH	0.8VDDA		VDDA		
Output low level voltage	VOL	GND		0.2VDDA		
Differential input high threshold	RXVTH	0.2	-	-	V	Note 1
Differential input low threshold	RXVTL	-	-	-0.2	V	Note 1
Input voltage range (singled-end)	RXVIN	0	-	$VDDA - 1.2 + VID /2$	V	Note 1
Input differential voltage	VID	0.2	-	0.6	V	Note 1
Differential Input Common Mode Voltage	RXVCM	$ VID /2$	-	$VDDA - 1.2$	V	Note 1

Note 1: LVDS interface signal DC characteristic

Single-end Signal

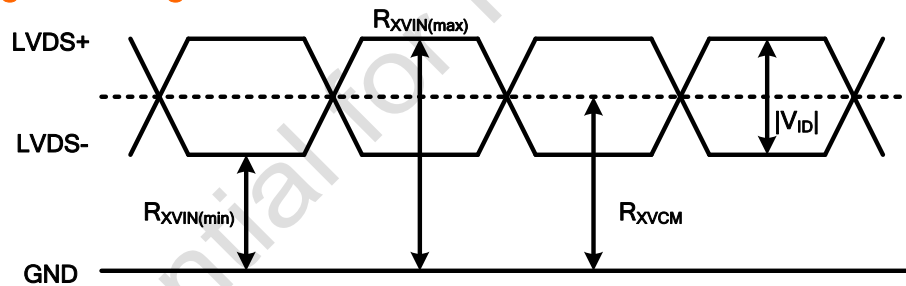

Differential Signal

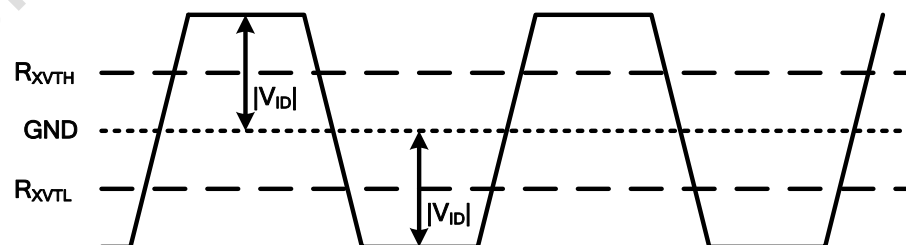
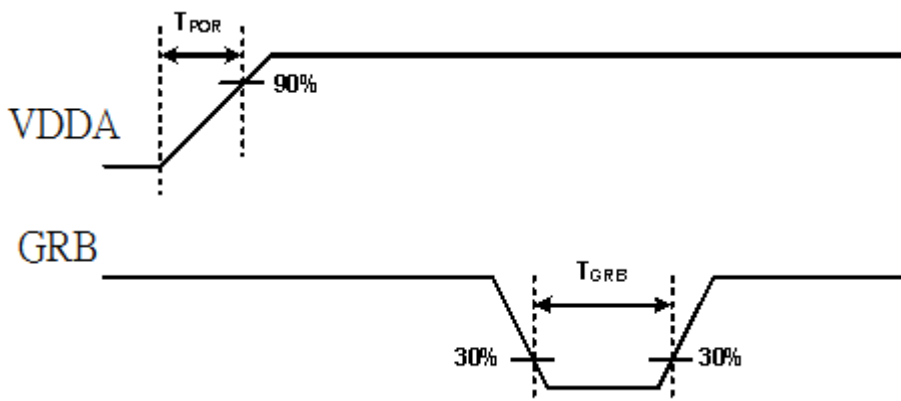

Fig. 5-1. LVDS DC characteristics diagram

5.1.3 Input AC characteristics

Parameter	Symbol	Min.	Typ.	Max.	Unit	Remark
VDDA power on slew time	T_{POR}	10	-	15	ms	From 0V to 90% VDDA Note 1
GRB active pulse width	T_{GRB}	1	-	20	ms	VDDA = 3.3 V

Note 1: the inrush current spec should follow VDDA power on slew time min value is 10ms and max value is 15ms. Inrush current maybe out of spec.(max:571mA)



5.1.4 Differential signal AC characteristics

Parameter	Symbol	Min.	Typ.	Max.	Unit	Remark
Clock frequency	R_{XFCLK}	25	-	72	MHz	$ VID =200mV$ $RXVCM=1.2V$
Input Data Skew Margin	T_{RSKM}			400	ps	

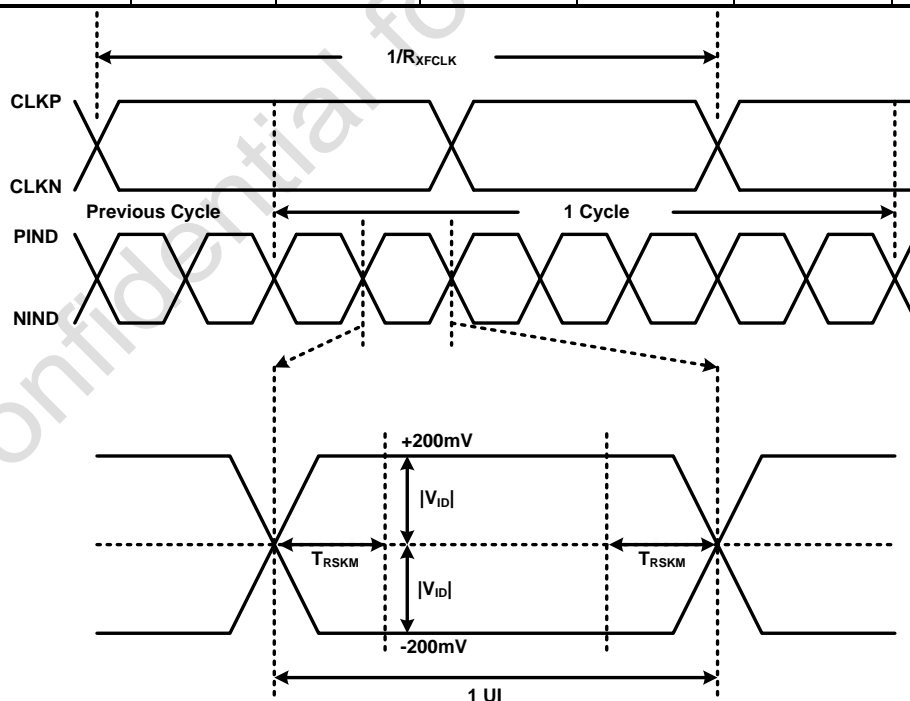

Fig. 5-3. LVDS AC characteristics diagram

5.2 Backlight Unit Driving

5.2.1 Parameter guideline for LED

Following characteristics are measured under stable condition at 25°C (Room Temperature).

Symbol	Parameter	Min.	Typ.	Max.	Unit	Remark
VLED	Input Voltage	10.8	12	13.2	Volt	
ILED	Input Current	-	400	-	mA	VLED =12V,100% Dimming
Irush	Inrush Current	-	-	1.0	A	Note.7
PLED	Power Consumption	-	4.8	-	Watt	VLED =12V,100% Dimming
FPWM	PWM Dimming Frequency	200	-	20K	Hz	
Dimming	Swing Voltage High	3	4	5	Volt	Note 1,2
	Swing Voltage Low	0	0	0.6	Volt	
DPWM	Dimming Duty Cycle (FPWM200Hz~5KHz)	5	-	100	%	
	Dimming Duty Cycle (FPWM5KHz~20KHz)	15	-	100	%	
IF	LED Forward Current	-	51.8	-	mA	Ta = 25°C
Enable	On Control Voltage	3	4	5	Volt	Note 3, 4
	Off Control Voltage	0	0	0.6	Volt	
Operating Life		70,000	-	-	Hrs	Note 5, 6, 7

Note 1: PWM dimming function can be operated by PWM signal. PWM duty cycle can adjust white Luminance.

(PWM High: ON and PWM Low: OFF)

Note 2: PWM signal cannot be floating and pull-down to ground when waiting.

Note 3: EN must be turned on late than VLED and PWM Signal.

Note 4: EN must be turned off early than VLED and PWM Signal.

Note 5: If LCD is driven by high current or at high ambient temperature & humidity condition. The operating life will be reduced.

Note 6: Operating life means brightness goes down to 50% initial brightness. Minimum operating life time is estimated data.

Note 7: The test condition is 51.8mA in 25°C room temperature.

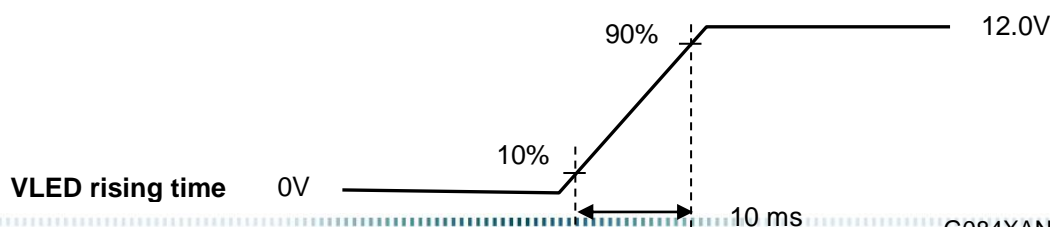

6. Signal Characteristic

6.1 Pixel Format Image

Following figure shows the relationship between input signal and LCD pixel format.

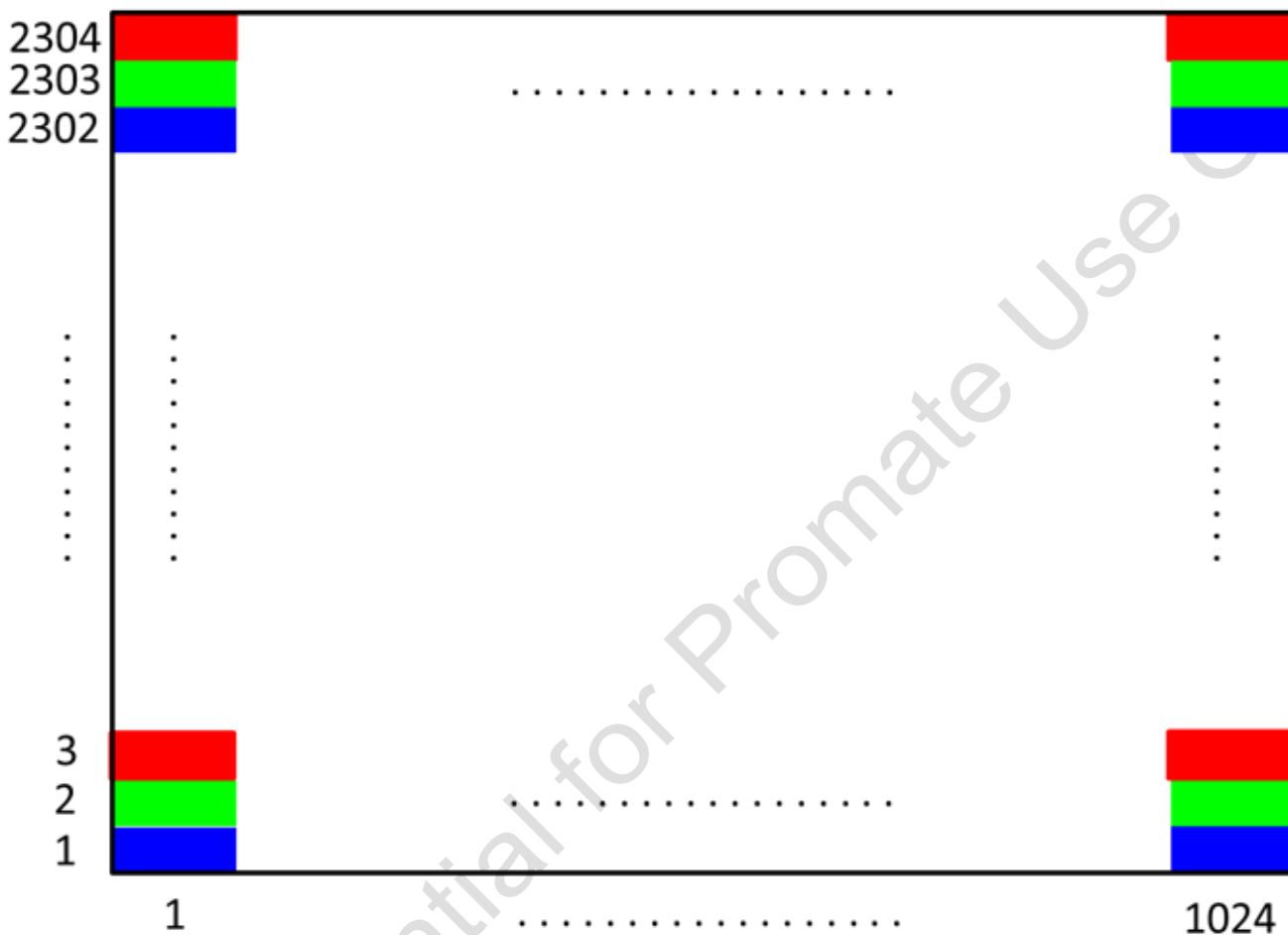

6.2 Scanning Direction

The following figures show the image seen from the front view. The arrow indicates the direction of scan.

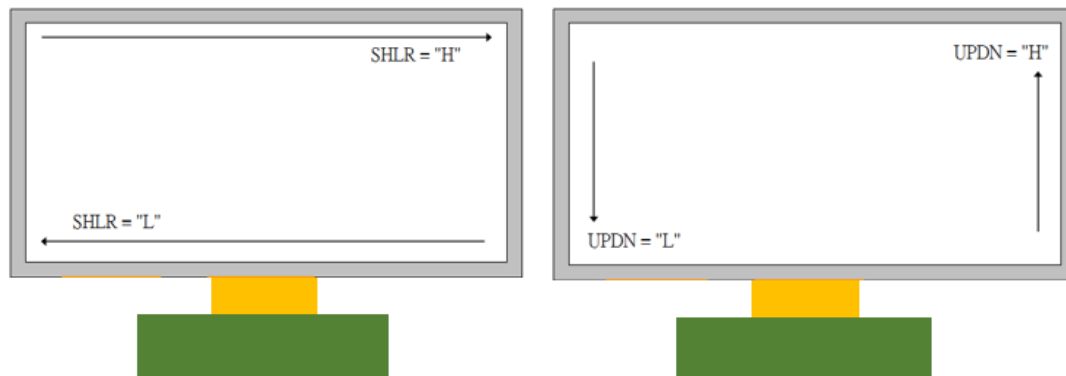

Note 1: TFT-LCD interface signal description is shown in section 6.3

6.3 TFT-LCD Interface Signal Description

No.	Pin Name	I/O	Description	Remarks
1	GND	G	GND	
2	GND	G	GND	
3	GND	G	GND	
4	NC	-	For ADP internal use	
5	NC	-	For ADP internal use	
6	NC	-	For ADP internal use	
7	NC	-	For ADP internal use	
8	GND	G	GND	
9	NC	-	For ADP internal use	
10	GND	G	GND	
11	GRB	I	Global Reset, "L" in reset state ; "H" normal operation.	
12	GND	G	GND	
13	NIND3-	I	Negative LVDS differential data input (Odd data)	
14	PIND3+	I	Positive LVDS differential data input (Odd data)	
15	GND	G	GND	
16	NIND2-	I	Negative LVDS differential data input	
17	PIND2+	I	Positive LVDS differential data input	
18	GND	G	GND	
19	NIND1-	I	Negative LVDS differential data input	
20	PIND1+	I	Positive LVDS differential data input	
21	GND	G	GND	
22	NIND0	I	Negative LVDS differential data input	
23	PIND0	I	Positive LVDS differential data input	
24	GND	G	GND	
25	CLKN-	I	Negative LVDS differential clock input	
26	CLKP+	I	Positive LVDS differential clock input	
27	GND	G	GND	
28	NC	-	For ADP internal use, suggest to keep H level	
29	NC	-	For ADP internal use, suggest to keep H level	
30	GND	G	GND	
31	SHLR	I	Horizontal scan direction control. "H" Left to Right; "L" Right to Left.	
32	UPDN	I	Vertical scan direction control. "H" Down to Up; "L" Up to Down.	
33	GND	G	GND	
34	NC	-	For ADP internal use	
35	GND	G	GND	
36	LVBIT	I	6/8 bits select, "L" 6-bit. ; "H" 8-bit	

37	NC	-	For ADP internal use	
38	GND	G	GND	
39	VDDA	PI	Display power (3.3 V)	
40	VDDA	PI	Display power (3.3 V)	

I: Digital signal input, O: Digital signal output, G: GND, PI: Power input;

Connector Pin position:

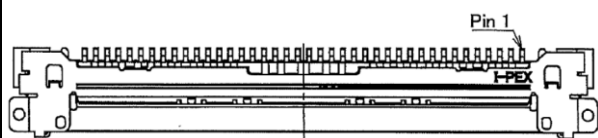

6.4 Interface Timing

6.4.1 Timing Characteristics

Parameter	Symbol	Min.	Typ.	Max.	Unit.
CLK Frequency	F_{CLK}	57.3	63	66	MHz
Period	T_H	1182	1284	1310	CLK
Horizontal display area	T_{HD}	1024			CLK
Blanking	$T_{HBP} + T_{HFP}$	158	260	286	CLK
Period	T_V	808	818	852	HS
Vertical display area	T_{VD}	768			HS
Blanking	$T_{VBP} + T_{VFP}$	40	50	84	HS

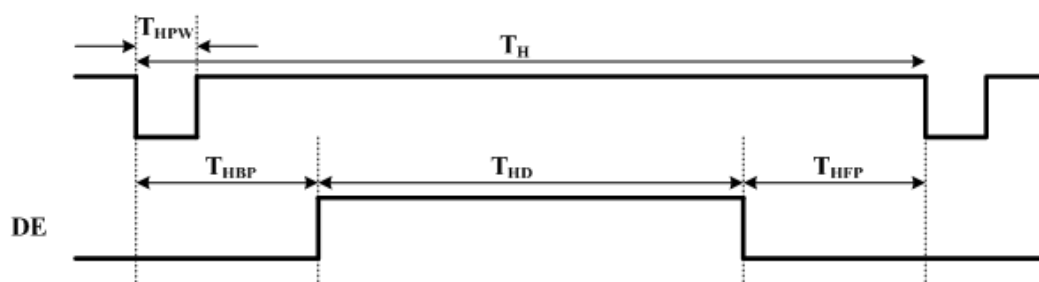
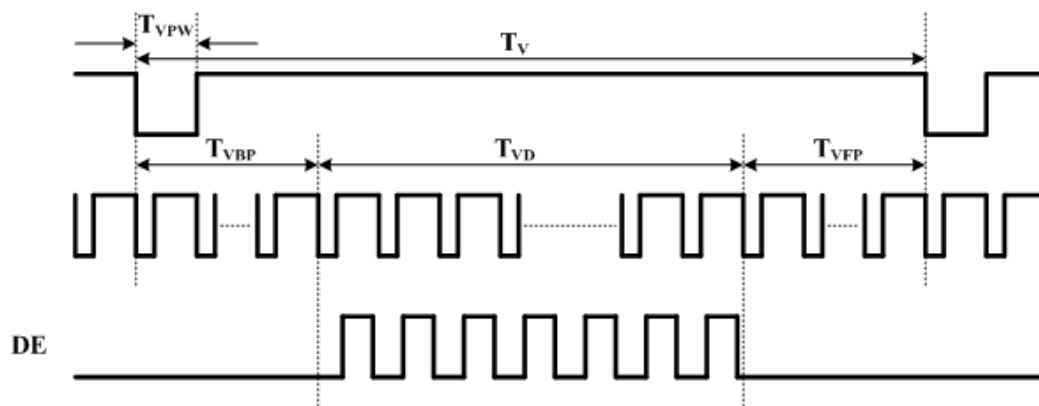

6.4.2 The Input Data Format

Differential Input Data Format

b. 6 bits format (LVBIT = " L " ; DE mode)

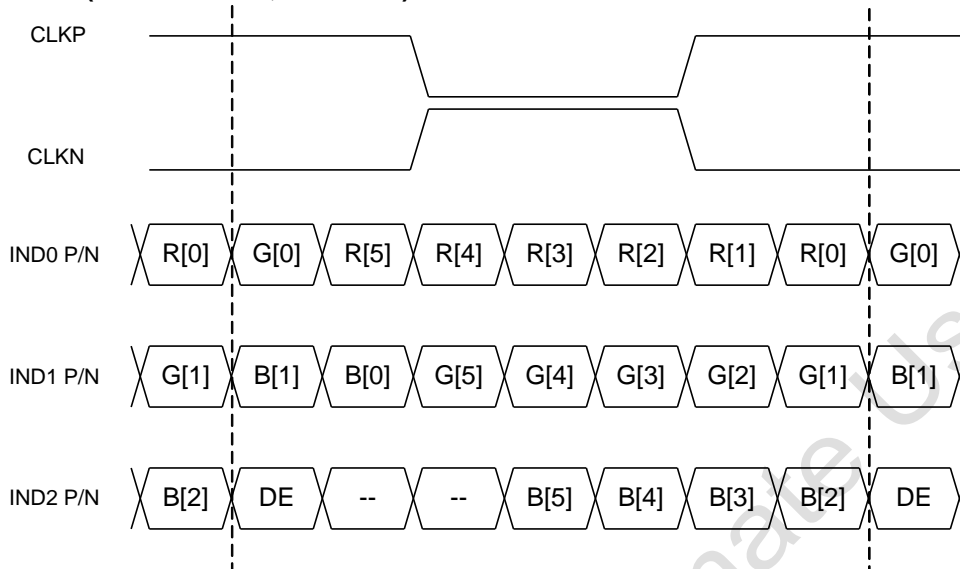

c. 8 bits format (LVBIT = " H " ; DE mode), note 1

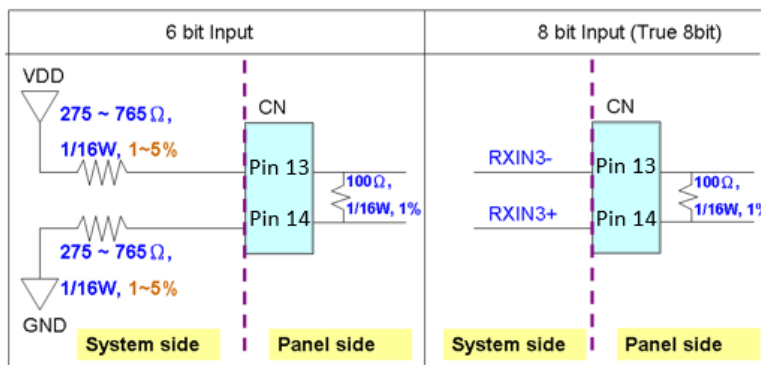
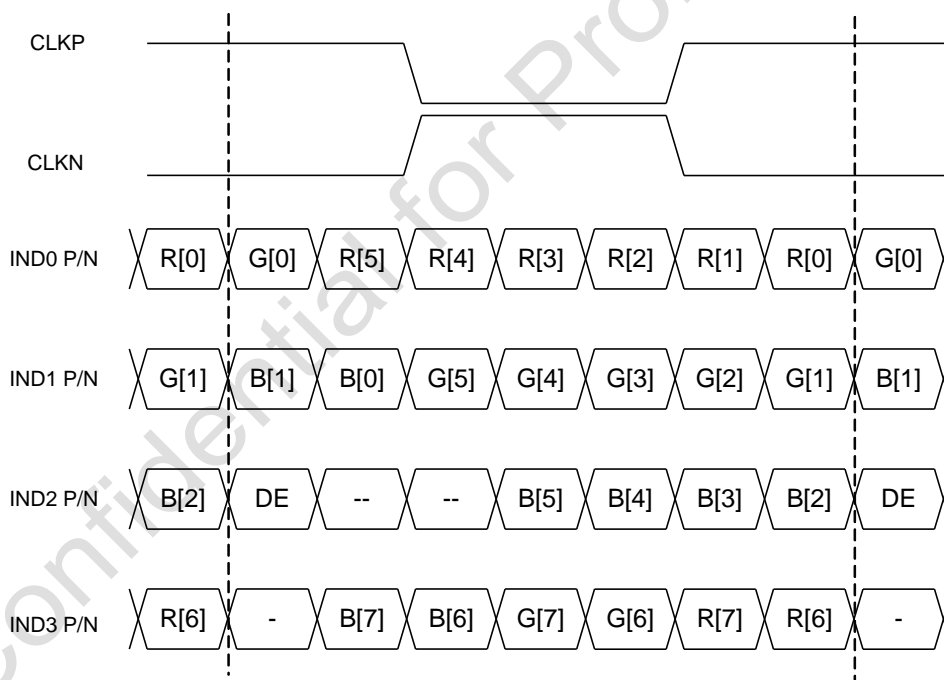

6.5 Power ON/OFF Sequence

The LCD adopts high voltage driver IC, so it could be permanently damaged under a wrong power on/off sequence. The suggested LCD power sequence is below:

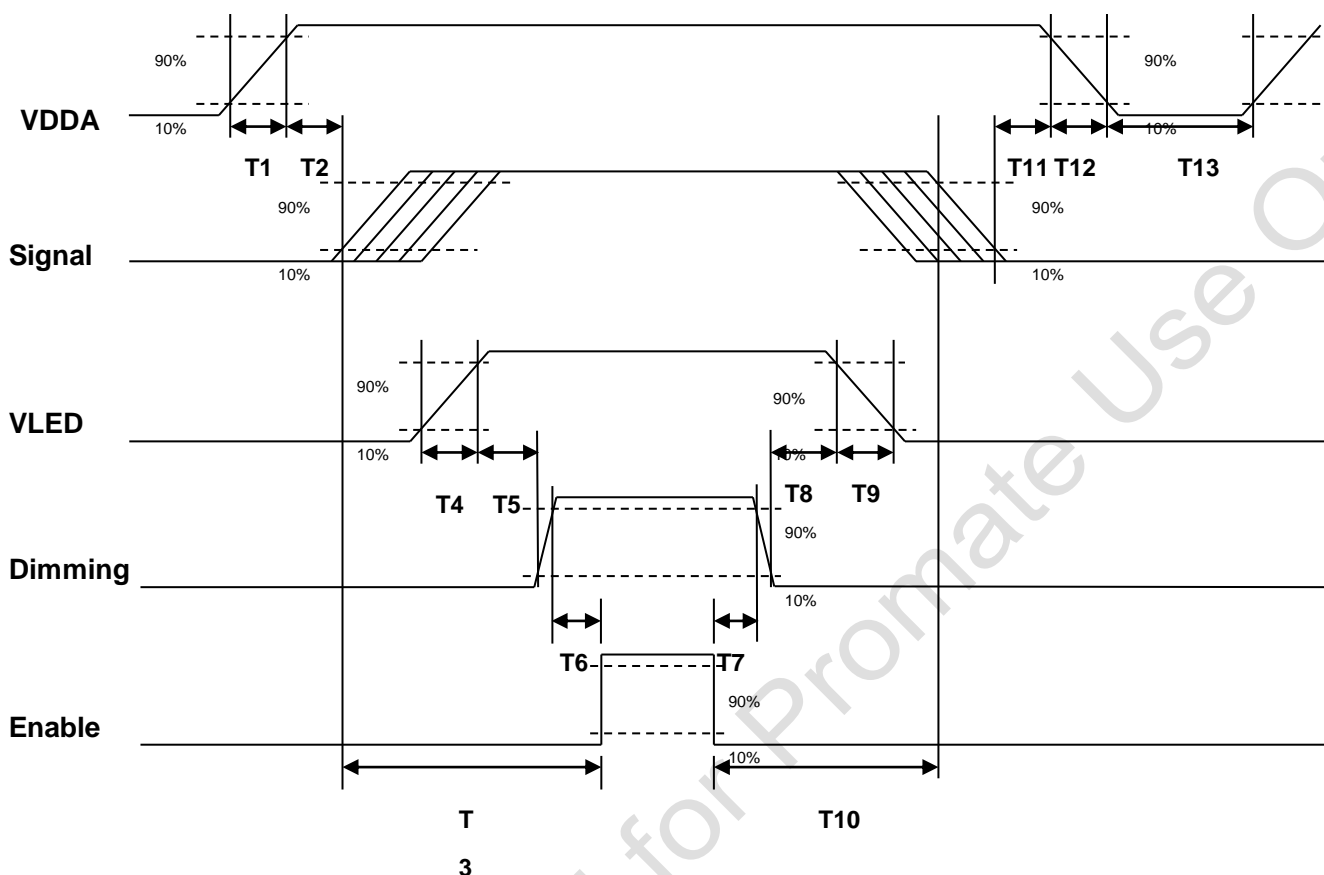

Parameter	Value			Unit
	Min.	Typ.	Max.	
T1	10	-	15	[ms]
T2	1	-	10	[ms]
T3	250	-	-	[ms]
T4	0.5	-	10	[ms]
T5	10	-	-	[ms]
T6	10	-	-	[ms]
T7	0	-	-	[ms]
T8	10	-	-	[ms]
T9	-	-	10	[ms]
T10	110	-	-	[ms]
T11	1	-	-	[ms]
T12	-	-	10	[ms]
T13	1000	-	-	[ms]

7. Connector & Pin Assignment

7.1 TFT- LCD Signal (CN1): LCD Connector

Manufacturer	IPEX
Connector Model Number	IPEX-20765-040E-11A or compatible
Adaptable Plug	IPEX-20453-040T-01 or compatible

Pin#	Symbol	Pin#	Symbol
1	GND	21	GND
2	GND	22	NIND0
3	GND	23	PIND0
4	NC	24	GND
5	NC	25	CLKN
6	NC	26	CLKP
7	NC	27	GND
8	GND	28	NC
9	NC	29	NC
10	GND	30	GND
11	GRB	31	SHLR
12	GND	32	UPDN
13	NIND3	33	GND
14	PIND3	34	NC
15	GND	35	GND
16	NIND2	36	LVBIT
17	PIND2	37	NC
18	GND	38	GND
19	NIND1	39	VDD
20	PIND1	40	VDD

7.2 LED Backlight Unit (CN2): Backlight Connector

Manufacturer	JAE
Connector Model Number	FI-S6P-HFE or compatible
Mating Connector Model Number	FI-S6S or compatible

Pin #	Symbol	Pin #	Symbol
1	V _{LED}	4	GND
2	V _{LED}	5	Enable
3	GND	6	Dimming

7.3 PIN 1 definition of CN1 and CN2

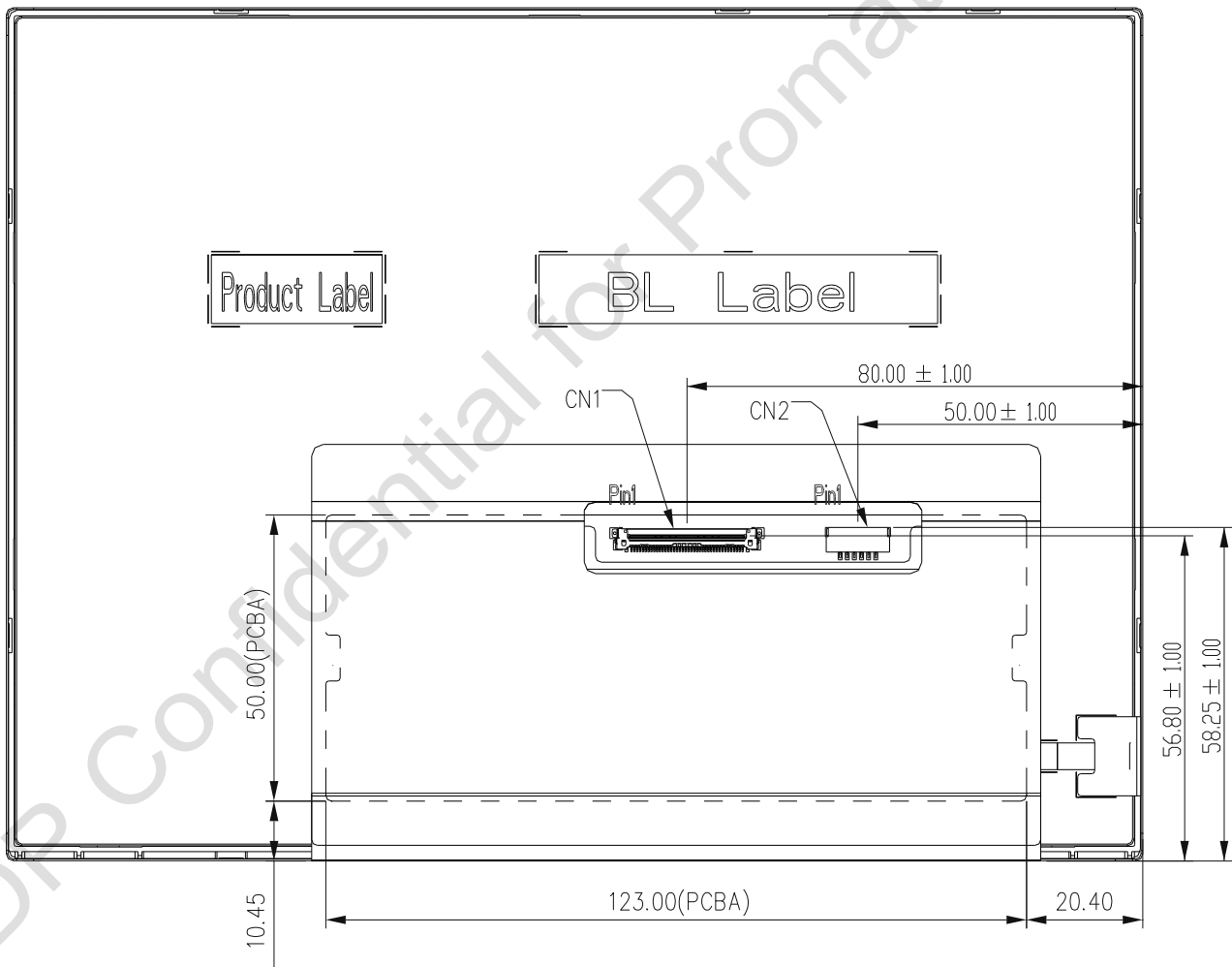

8. Reliability Test Criteria (Preliminary)

Items	Required Condition	Note
Temperature Humidity Bias	40°C, 90%RH, 300 hours	
High Temperature Operation	85°C, 300 hours	
Low Temperature Operation	-30°C, 300 hours	
Hot Storage	85°C, 300 hours	
Cold Storage	-30°C, 300 hours	
Thermal Shock Test	-20°C/ 30 min, 60°C/ 30 min, 100cycles, 40°C minimum ramp rate	
Hot Start Test	85°C/ 1Hr min. power on/off per 5 minutes, 5 times	
Cold Start Test	-30°C/ 1Hr min. power on/off per 5 minutes, 5 times	
Shock Test (Non-Operating)	50G, 20ms, Half-sine wave, ($\pm X$, $\pm Y$, $\pm Z$)	
Vibration Test (Non-Operating)	1.5G, (10~200Hz, Sine wave) 30 mins/axis, 3 direction (X, Y, Z)	
On/off test	On/10 sec, Off/10 sec, 30,000 cycles	
ESD	Contact = ± 8 kV, 1sec, 8 point, 10 times/point class B (R = 330 Ω , C = 150 pF) Air = ± 15 kV, 1sec, 8 point, 10 times/point class B (R = 330 Ω , C = 150 pF)	Note 1
EMI	30-230 MHz, limit 40 dBu V/m, 230-1000 MHz, limit 47 dBu V/m	

Note1: According to EN61000-4-2 ESD class B criteria, some performance degradation is allowed. TFT-LCD module is self-recoverable, no data lost and no hardware failures after test.

Note2:

- Water condensation is not allowed for each test items.
- Each test is done by new TFT-LCD module. Don't use the same TFT-LCD module repeatedly for reliability test.
- The reliability test is performed only to examine the TFT-LCD module capability.
- To inspect TFT-LCD module after reliability test, please store it at room temperature and room humidity for 24 hours at least in advance.

9. Mechanical Characteristics

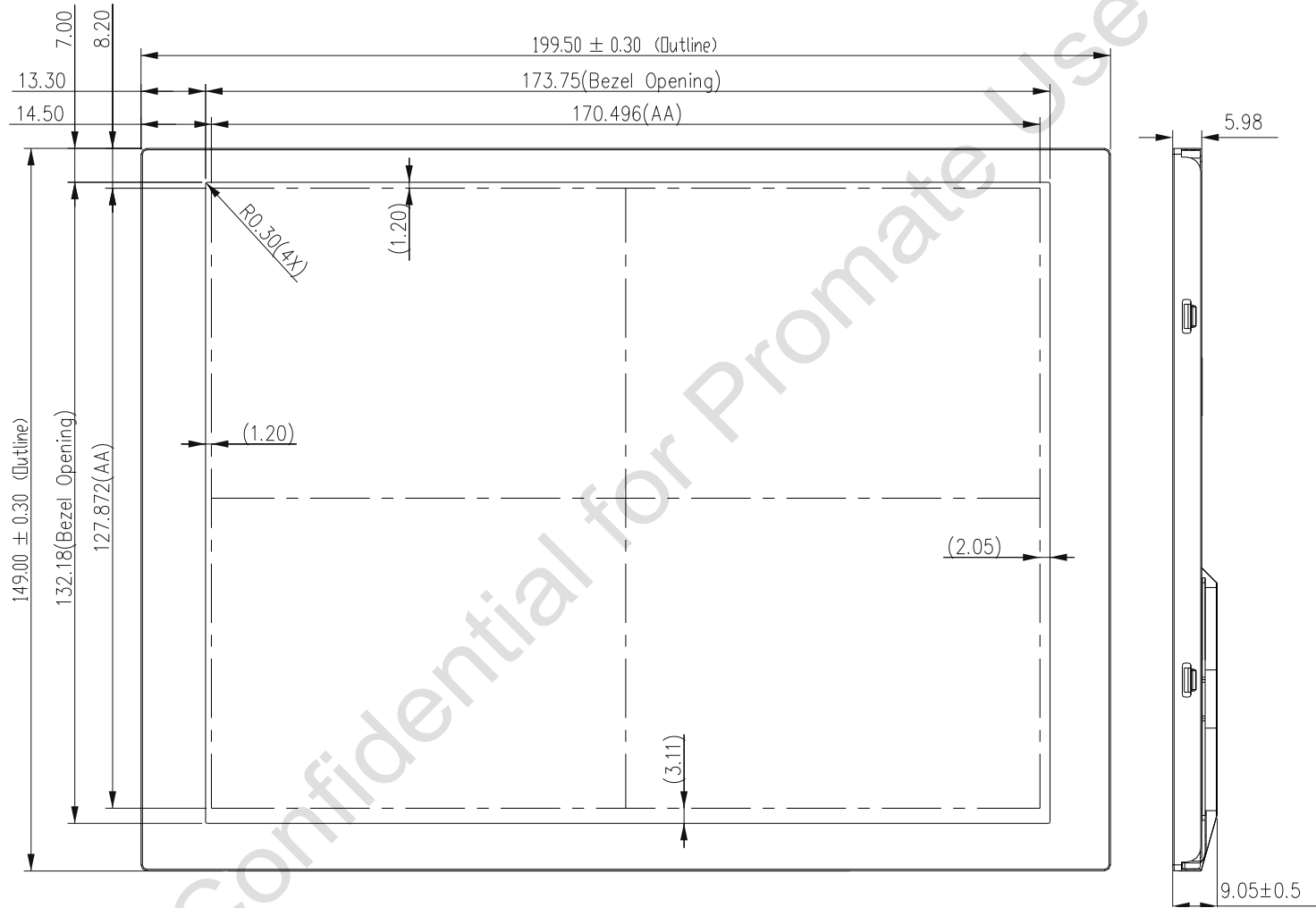

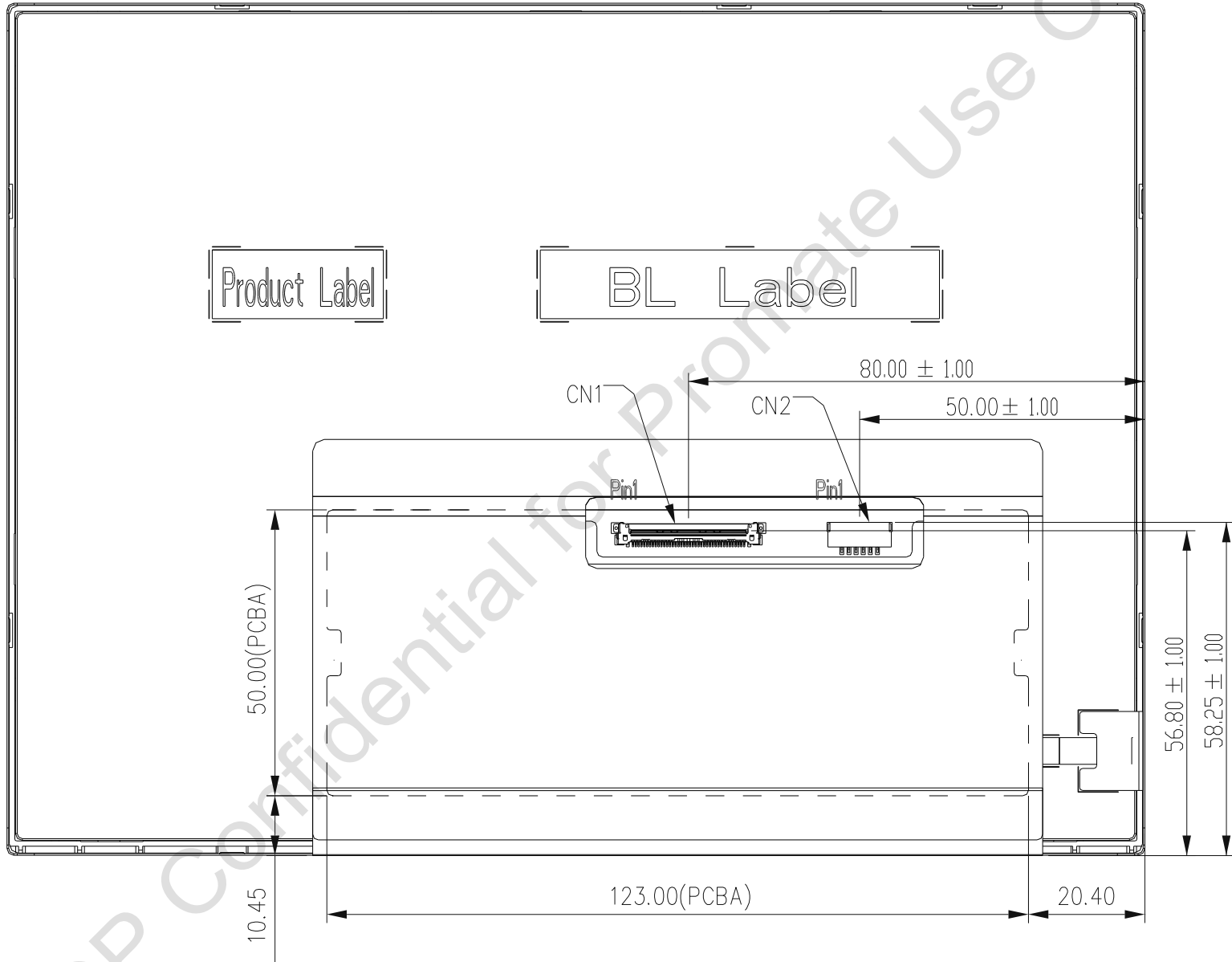

10. Label and Packaging

10.1 Shipping Label (on the rear side of TFT-LCD display)

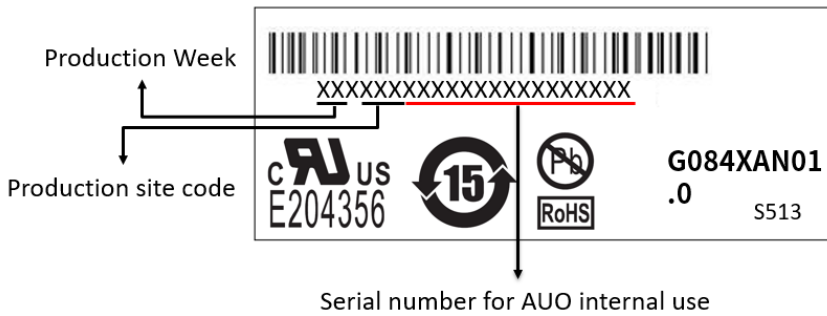

10.2 Carton Package

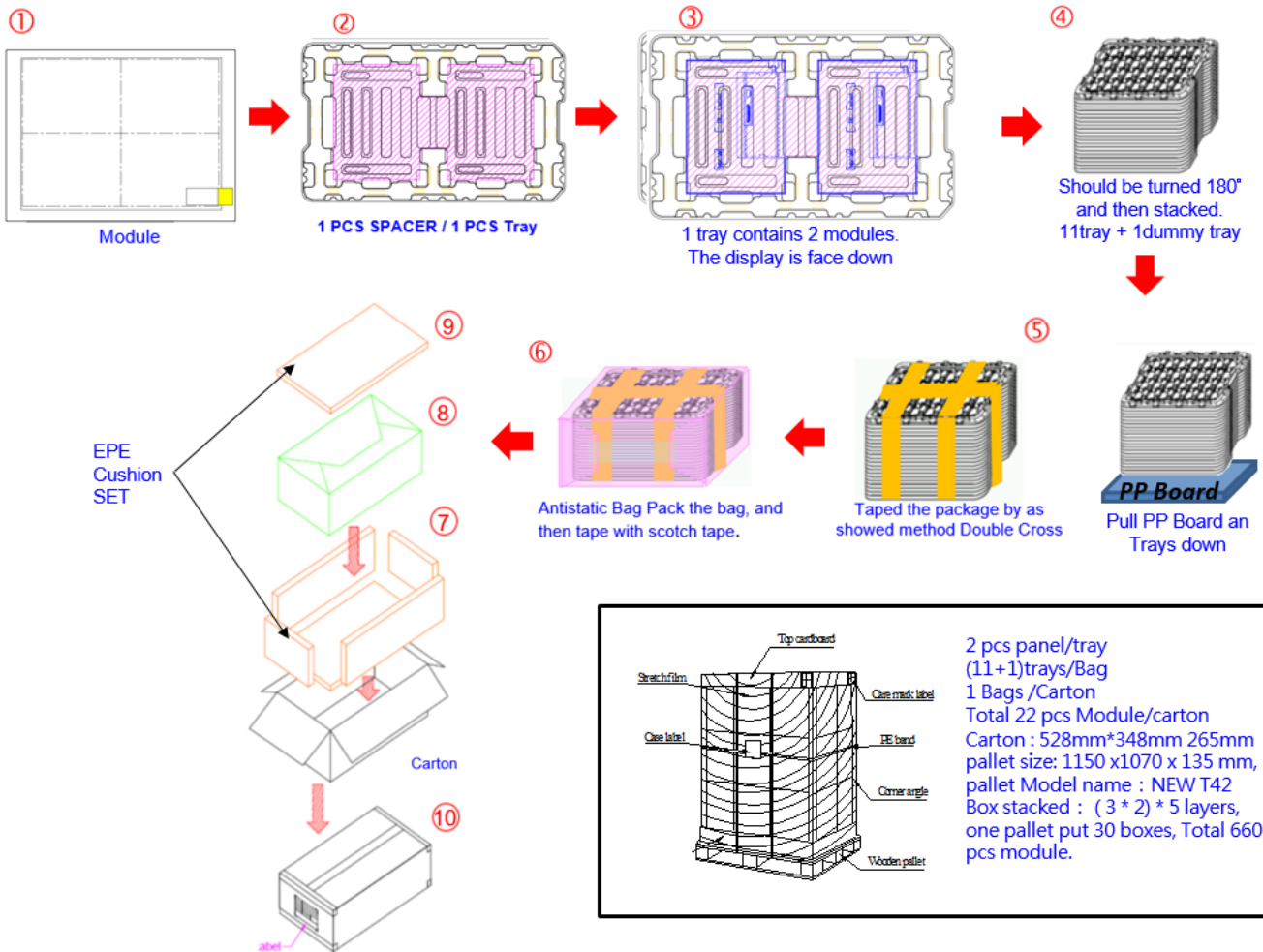

ADT

11 Safety

11.1 Keen Edge Requirements

There will be no keen edges or corners on the display assembly that could cause injury.

11.2 Materials

11.2.1 Toxicity

There will be no carcinogenic materials used anywhere in the TFT-LCD module. If toxic materials are used, they will be reviewed and approved by the responsible AUO toxicologist.

11.2.2 Flammability

All components including electrical components that do not meet the flammability grade UL94-V1 in the TFT-LCD Module will complete the flammability rating exception approval process.

The printed circuit board will be made from material rated 94-V1 or better. The actual UL flammability rating will be printed on the printed circuit board.

11.3 Capacitors

If any polarized capacitors are used in the TFT-LCD module, provisions will be made to keep them from being inserted backwards.

11.4 National Test Lab Requirement

The TFT-LCD Module will satisfy all requirements for compliance to UL 60950 (U.S.A. Information Technology Equipment).