

Small Signal Switching Diode, Dual in Series

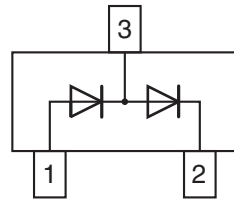

18109

FEATURES

- Fast switching speed
- High conductance
- Surface mount package ideally suited for automatic insertion
- Connected in series
- AEC-Q101 qualified available
- Base P/N-E3 - RoHS-compliant, commercial grade
- Base P/N-HE3 - RoHS-compliant, AEC-Q101 qualified
- Material categorization: for definitions of compliance please see www.vishay.com/doc?99912

RoHS
COMPLIANT

DESIGN SUPPORT TOOLS click logo to get started

MECHANICAL DATA

Case: SOT-23

Weight: approx. 8.8 mg

Packaging codes / options:

18/10K per 13" reel (8 mm tape), 10K/box

08/3K per 7" reel (8 mm tape), 15K/box

PARTS TABLE				
PART	ORDERING CODE	CIRCUIT CONFIGURATION	TYPE MARKING	REMARKS
BAV99	BAV99-E3-08 or BAV99-E3-18	Dual serial	JE	Tape and reel
	BAV99-HE3-08 or BAV99-HE3-18			

ABSOLUTE MAXIMUM RATINGS ($T_{amb} = 25\text{ }^{\circ}\text{C}$, unless otherwise specified)					
PARAMETER	TEST CONDITION	SYMBOL	VALUE	UNIT	
Non repetitive peak reverse voltage		V_{RM}	100	V	
Repetitive peak reverse voltage = working peak reverse voltage = DC blocking voltage		$V_{RRM} = V_{RWM} = V_R$	70		
Peak forward surge current	$t_p = 1\text{ s}$	I_{FSM}	1	A	
	$t_p = 1\text{ }\mu\text{s}$		4.5		
Average forward current	Half wave rectification with resistive load and $f \geq 50\text{ MHz}$, on ceramic substrate 10 mm x 8 mm x 0.7 mm	$I_{F(AV)}$	150	mA	
Forward current	On ceramic substrate 10 mm x 8 mm x 0.7 mm	I_F	250		
Power dissipation	On ceramic substrate 10 mm x 8 mm x 0.7 mm	P_{tot}	300	mW	

THERMAL CHARACTERISTICS ($T_{amb} = 25\text{ }^{\circ}\text{C}$, unless otherwise specified)					
PARAMETER	TEST CONDITION	SYMBOL	VALUE	UNIT	
Junction ambient	On ceramic substrate 10 mm x 8 mm x 0.7 mm	R_{thJA}	430	K/W	
Junction and storage temperature range		$T_J = T_{stg}$	-55 to +150	$^{\circ}\text{C}$	
Operating temperature range		T_{op}	-55 to +150	$^{\circ}\text{C}$	

ELECTRICAL CHARACTERISTICS ($T_{amb} = 25\text{ }^{\circ}\text{C}$, unless otherwise specified)						
PARAMETER	TEST CONDITION	SYMBOL	MIN.	TYP.	MAX.	UNIT
Forward voltage	$I_F = 1\text{ mA}$	V_F			0.715	V
	$I_F = 10\text{ mA}$				0.855	V
	$I_F = 50\text{ mA}$				1	V
	$I_F = 150\text{ mA}$				1.25	V
Reverse current	$V_R = 70\text{ V}$	I_R			2500	nA
	$V_R = 70\text{ V}, T_j = 150\text{ }^{\circ}\text{C}$				50	μA
	$V_R = 25\text{ V}, T_j = 150\text{ }^{\circ}\text{C}$				30	μA
Diode capacitance	$V_R = 0, f = 1\text{ MHz}$	C_D			1.5	pF
Reverse recovery time	$I_F = 10\text{ mA}$ to $i_R = 1\text{ mA}$, $V_R = 6\text{ V}, R_L = 100\text{ }\Omega$	t_{rr}			6	ns

TYPICAL CHARACTERISTICS ($T_{amb} = 25\text{ }^{\circ}\text{C}$, unless otherwise specified)

Fig. 1 - Forward Current vs. Forward Voltage

 Fig. 2 - Peak forward current $/_{FM} = f(t_p)$
LAYOUT FOR R_{thJA} TEST

Thickness:

Fiberglass 1.5 mm (0.059 inches)

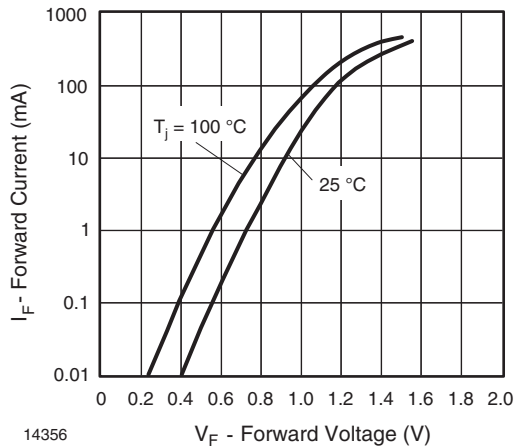
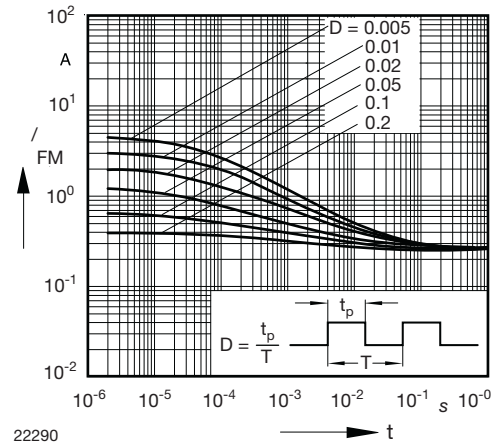
Copper leads 0.3 mm (0.012 inches)

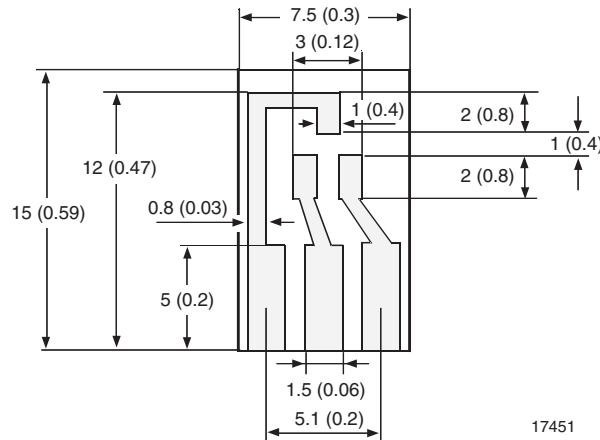

17451



PACKAGE DIMENSIONS in millimeters (inches): **SOT-23**

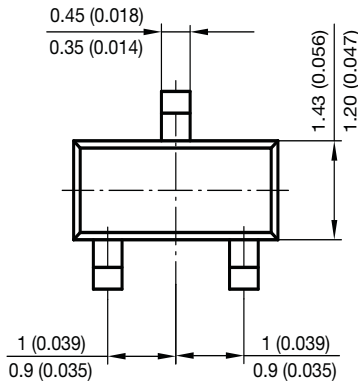
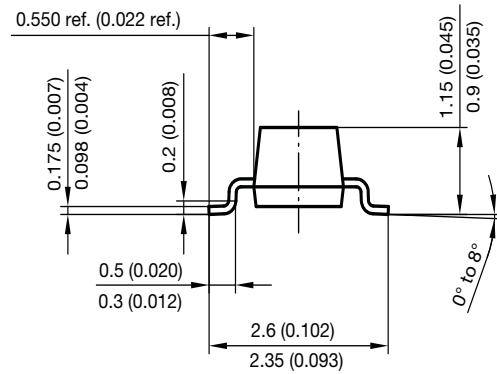
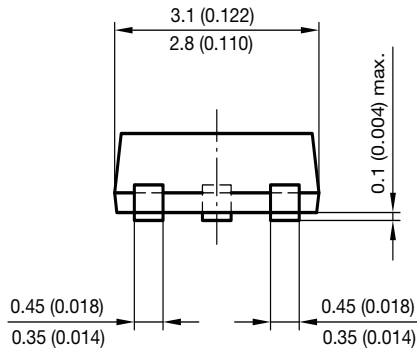

Foot print recommendation:

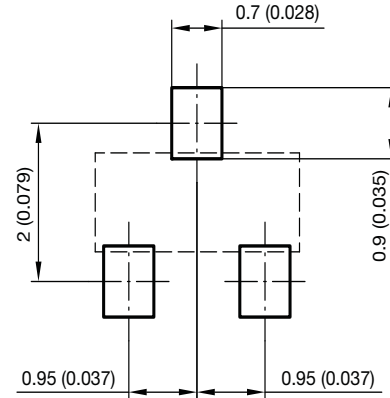

Document no.: 6.541-5014.01-4
Rev. 8 - Date: 23.Sept.2009
17418



April 2014

BAV99 — 200 mA 70 V High Conductance Ultra-Fast Switching Diode

BAV99

200 mA 70 V High Conductance Ultra-Fast Switching Diode

Features

- High Conductance: $I_F = 200$ mA
- Fast Switching Speed: $t_{rr} < 6$ ns Maximum
- Small Plastic SOT-23 Package
- Series-Pair Configuration

Applications

- High-Speed Switching Applications

Description

The BAV99 is a 350 mW high-speed switching diode array with series-pair diode configuration. It achieves high-current conductivity, up to 200 mA, in a very small 7mm^2 footprint. These features make the BAV99 optimal for area-constrained applications that need a little extra power capability.

For common cathode and common anode high-speed switching diodes, explore Fairchild's BAV70 and BAW56. Looking for more options in the SOT-23 package? Check Fairchild's MMBD family.

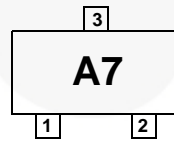
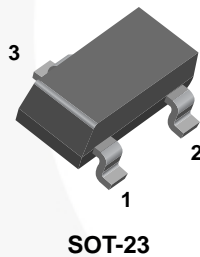

Connection Diagram

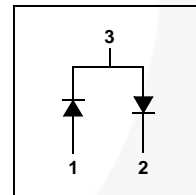

Ordering Information

Part Number	Marking	Package	Packing Method
BAV99	A7	SOT-23 3L	Tape and Reel, Reel 7 inch
BAV99_D87Z	A7	SOT-23 3L	Tape and Reel, Reel 13 inch

Absolute Maximum Ratings⁽¹⁾

Stresses exceeding the absolute maximum ratings may damage the device. The device may not function or be operable above the recommended operating conditions and stressing the parts to these levels is not recommended. In addition, extended exposure to stresses above the recommended operating conditions may affect device reliability. The absolute maximum ratings are stress ratings only. Values are at $T_A = 25^\circ\text{C}$ unless otherwise noted.

Symbol	Parameter	Value	Unit
V_{RRM}	Maximum Repetitive Reverse Voltage	70	V
$I_{F(AV)}$	Average Rectified Forward Current	200	mA
I_{FSM}	Non-Repetitive Peak Forward Surge Current	Pulse Width = 1.0 Second	1.0
		Pulse Width = 300 Microseconds	8.0
T_{STG}	Storage Temperature Range	-55 to +150	$^\circ\text{C}$
T_J	Operating Junction Temperature Range	-55 to +150	$^\circ\text{C}$

Note:

- These ratings are based on a maximum junction temperature of 150°C .
These are steady-state limits. Fairchild Semiconductor should be consulted on applications involving pulsed or low-duty cycle operations.

Thermal Characteristics⁽²⁾

Values are at $T_A = 25^\circ\text{C}$ unless otherwise noted.

Symbol	Parameter	Value	Unit
P_D	Power Dissipation	350	mW
$R_{\theta JA}$	Thermal Resistance, Junction to Ambient	357	$^\circ\text{C}/\text{W}$

Note:

- PCB size: FR-4, 76 mm x 114 mm x 1.57 mm (3.0 inch x 4.5 inch x 0.062 inch) with minimum land pattern size.

Electrical Characteristics

Values are at $T_A = 25^\circ\text{C}$ unless otherwise noted.

Symbol	Parameter	Conditions	Min.	Max.	Unit
V_R	Breakdown Voltage, per Diode	$I_R = 100 \mu\text{A}$	70		V
V_F	Forward Voltage, per Diode	$I_F = 1 \text{ mA}$		715	mV
		$I_F = 10 \text{ mA}$		855	
		$I_F = 50 \text{ mA}$		1.00	V
		$I_F = 150 \text{ mA}$		1.25	
I_R	Reverse Leakage, per Diode	$V_R = 70 \text{ V}$		2.5	μA
		$V_R = 25 \text{ V}, T_A = 150^\circ\text{C}$		30.0	
		$V_R = 70 \text{ V}, T_A = 150^\circ\text{C}$		50.0	
C_T	Total Capacitance, per Diode	$V_R = 0 \text{ V}, f = 1.0 \text{ MHz}$		1.5	pF
t_{rr}	Reverse-Recovery Time, per Diode	$I_F = I_R = 10 \text{ mA},$ $I_{RR} = 1 \text{ mA},$ $R_L = 100 \Omega$		6.0	ns

Typical Performance Characteristics

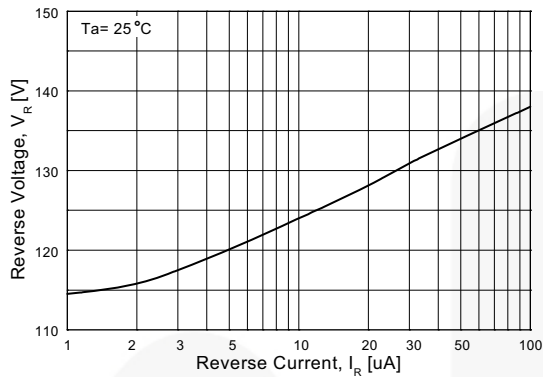

Figure 1. Reverse Voltage vs. Reverse Current

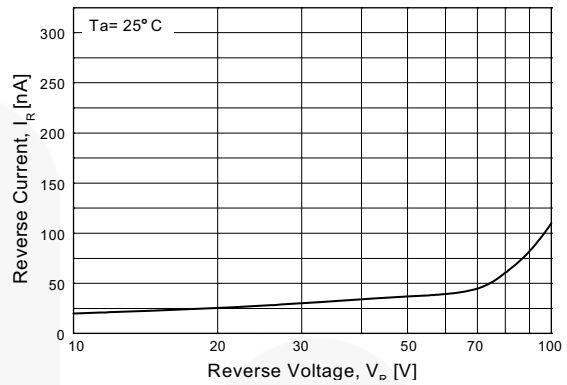
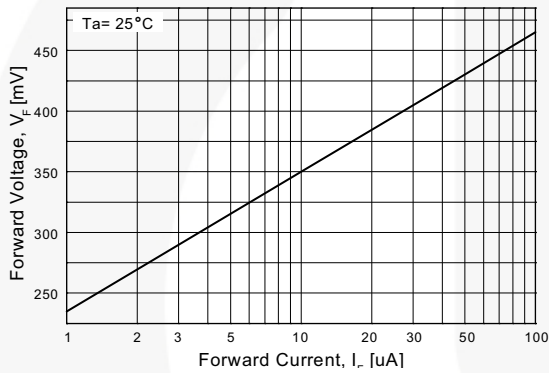
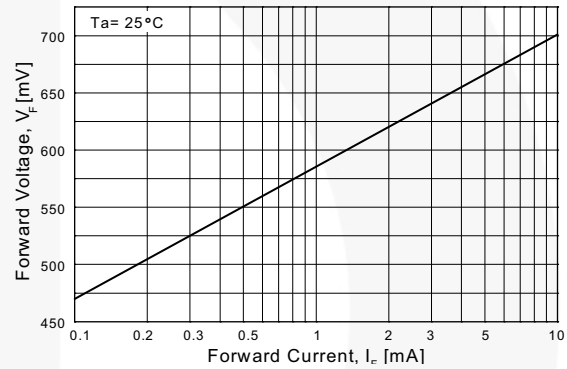

Figure 2. Reverse Current vs. Reverse Voltage



**Figure 3. Forward Voltage vs. Forward Current
V_F - 1 to 100 μ A**



**Figure 4. Forward Voltage vs. Forward Current
V_F - 0.1 to 10 mA**

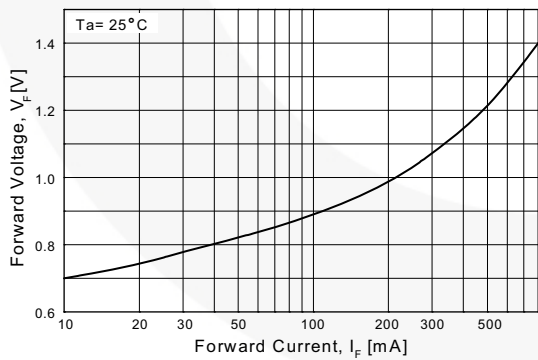

**Figure 5. Forward Voltage vs. Forward Current
V_F - 10 to 800 mA**

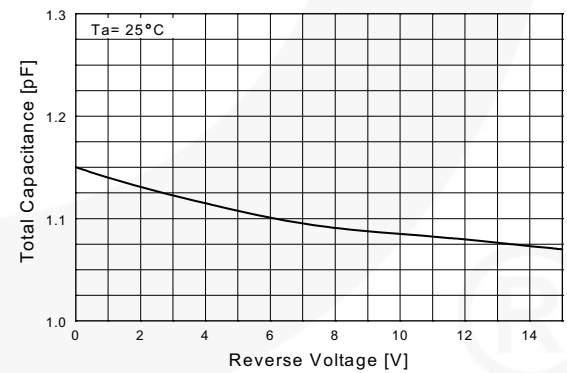

Figure 6. Total Capacitance vs. Reverse Voltage

Typical Performance Characteristics (Continued)

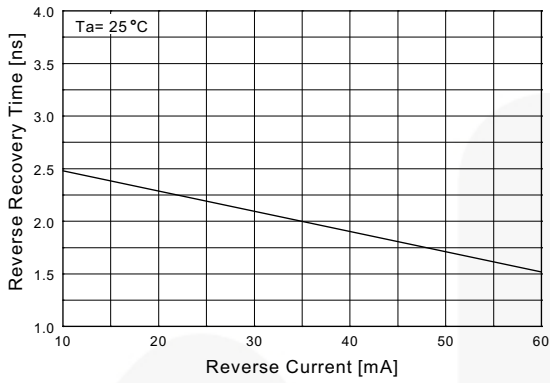

Figure 7. Reverse-Recovery Time vs. Reverse Current

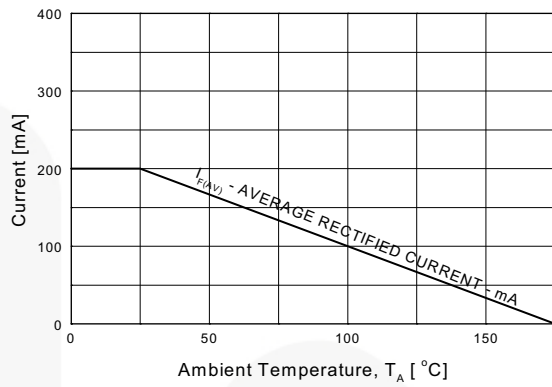

Figure 8. Average Rectified Current ($I_{F(AV)}$) vs. Ambient Temperature (T_A)

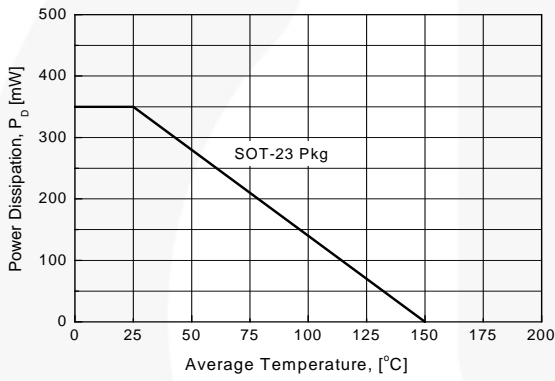

Figure 9. Power Derating Curve

Physical Dimensions

SOT-23

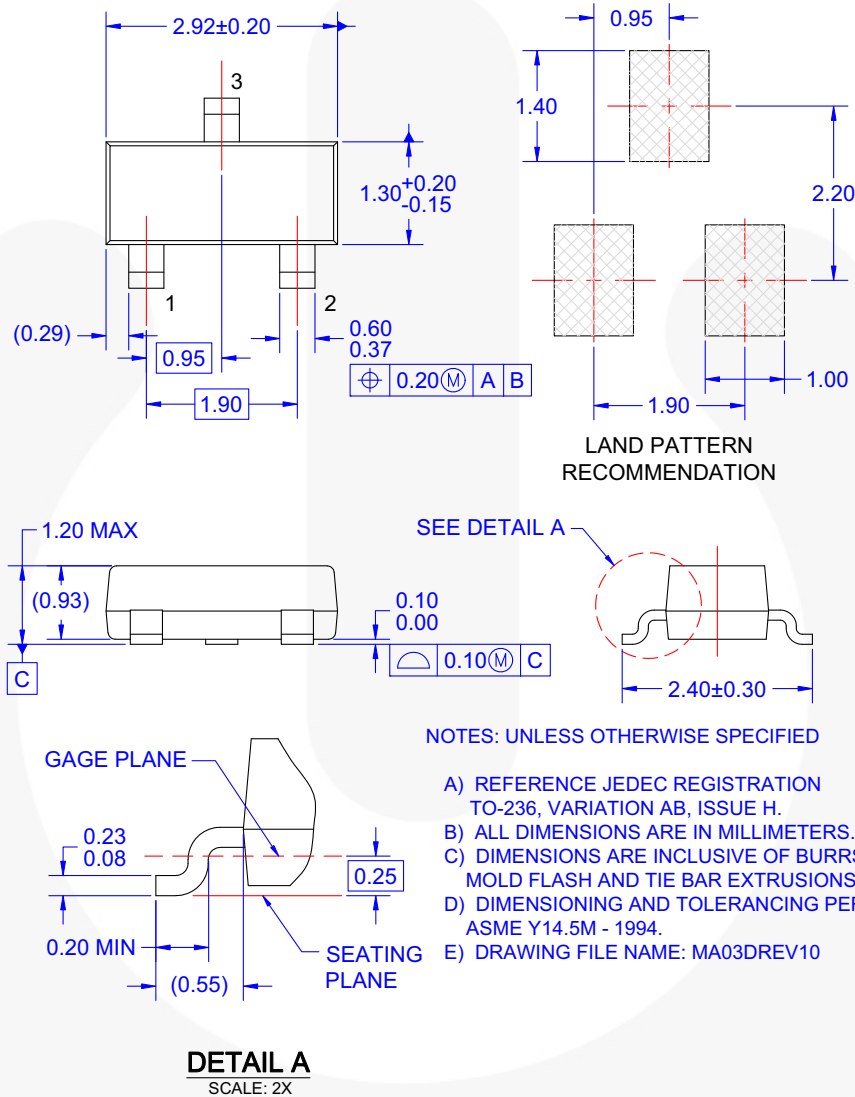

Figure 10. 3-LEAD, SOT23, JEDEC TO-236, LOW PROFILE

Package drawings are provided as a service to customers considering Fairchild components. Drawings may change in any manner without notice. Please note the revision and/or date on the drawing and contact a Fairchild Semiconductor representative to verify or obtain the most recent revision. Package specifications do not expand the terms of Fairchild's worldwide terms and conditions, specifically the warranty therein, which covers Fairchild products.

Always visit Fairchild Semiconductor's online packaging area for the most recent package drawings:
<http://www.fairchildsemi.com/dwg/MA/MA03D.pdf>

For current tape and reel specifications, visit Fairchild Semiconductor's online packaging area:
http://www.fairchildsemi.com/packaging_dwg/PKG-MA03D.pdf