

# TPS65217x Single-Chip PMIC for Battery-Powered Systems

## 1 Features

- **CHARGER/POWER PATH**
  - 2-A Output Current on Power Path
  - Linear Charger; 700-mA Maximum Charge Current
  - 20-V Tolerant USB and AC Inputs
  - Thermal Regulation, Safety Timers
  - Temperature Sense Input
- **STEP-DOWN CONVERTER (DCDC1, 2, 3)**
  - Three Step-Down Converter With Integrated Switching FETs
  - 2.25-MHz Fixed Frequency Operation
  - Power Save Mode at Light Load Current
  - Output Voltage Accuracy in PWM Mode  $\pm 2.0\%$
  - 100% Duty Cycle for Lowest Dropout
  - Typical 15- $\mu$ A Quiescent per Converter
  - Passive Discharge to Ground When Disabled
- **LDOs (LDO1, 2)**
  - Two Adjustable LDOs
  - LDO2 Can Be Configured to Track DCDC3
  - Typical 15- $\mu$ A Quiescent Current
- **LOAD SWITCHES (LDO3, 4)**
  - Two Independent Load Switches That Can Be Configured as LDOs
- **WLED DRIVER**
  - Internally Generated PWM for Dimming Control
  - 38-V Open LED Protection
  - Supports Two Strings of Up To 10 LEDs at 25 mA Each
  - Internal Low-Side Current Sinks
- **PROTECTION**
  - Undervoltage Lockout and Battery Fault Comparator
  - Always-On Push-Button Monitor
  - Hardware Reset Pin
  - Password Protected I<sup>2</sup>C<sup>®</sup> Registers
- **INTERFACE**
  - I<sup>2</sup>C Interface (Address 0x24)
  - Password Protected I<sup>2</sup>C Registers

## 2 Applications

- AM335x ARM<sup>®</sup> Cortex™-A8 Microprocessors
- Portable Navigation Systems
- Tablet Computing
- 5-V Industrial Equipment

## 3 Description

The TPS65217 is a single-chip power management IC specifically designed to support applications in portable and 5-V non-portable applications. It provides a linear battery charger for single-cell Li-ion and Li-Polymer batteries, dual-input power path, three step-down converters, four LDOs, and a high-efficiency boost converter to power two strings of up to 10 LEDs each. The system can be supplied by any combination of USB port, 5-V AC adaptor, or Li-Ion battery. The device is characterized across a -40°C to +105°C temperature range which makes it suitable for industrial applications. Three high-efficiency 2.25-MHz step-down converters can providing the core voltage, memory, and I/O voltage for a system.

### Device Information<sup>(1)</sup>

PART NUMBER	PACKAGE	BODY SIZE (NOM)
TPS65217A	VQFN (48)	6.00 mm x 6.00 mm
TPS65217B		
TPS65217C		
TPS65217D		

(1) For all available packages, see the orderable addendum at the end of the datasheet.

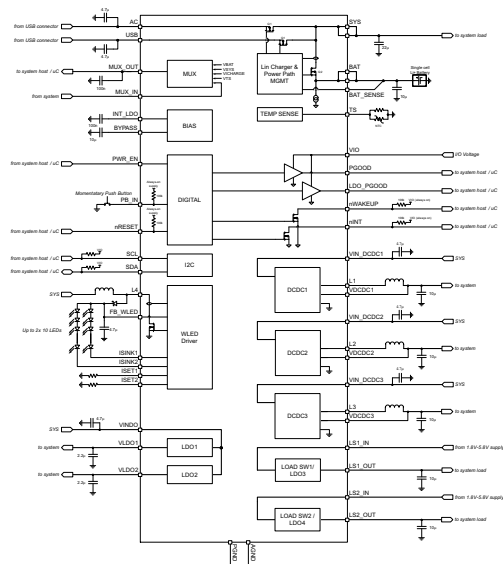



## 5 Description (continued)

These step-down converters enter a low power mode at light load for maximum efficiency across the widest possible range of load currents. For low-noise applications the devices can be forced into fixed frequency PWM using the I<sup>2</sup>C interface. The step-down converters allow the use of small inductors and capacitors to achieve a small solution size.

LDO1 and LDO2 can support system-standby mode. In SLEEP state output current is limited to 1 mA to reduce quiescent current whereas in normal operation they can support up to 100 mA each. LDO3 and LDO4 can be configured to support up to 400 mA each and can be configured as load switches instead of regulators. All four LDOs have a wide input voltage range that allows them to be supplied either from one of the DC-DC converters or directly from the system voltage node.

By default only LDO1 is always ON but any rail can be configured to remain up in SLEEP state. Especially the DC-DC converters can remain up in a low-power PFM mode to support system suspend mode.

The TPS65217 offers configurable power-up and power-down sequencing and several housekeeping functions such as power-good output, pushbutton monitor, hardware reset function and temperature sensor to protect the battery.

For details on specific applications please see our application note [SLVU551](#).

The TPS65217 comes in a 48-pin leadless package (6-mm x 6-mm QFN) with a 0.4-mm pitch.

## 6 Device Comparison Table

	TPS65217A (Targeted at AM335x - ZCE)		TPS65217B (Targeted at AM335x - ZCZ)		TPS65217C (Targeted at AM335x - ZCZ)		TPS65217D (Targeted at AM335x - ZCZ)	
	VOLTAGE (V)	SEQUENCE (STROBE)	VOLTAGE (V)	SEQUENCE (STROBE)	VOLTAGE (V)	SEQUENCE (STROBE)	VOLTAGE (V)	SEQUENCE (STROBE)
DCDC1	1.8	1	1.8	1	1.5	1	1.35	1
DCDC2	3.3	2	1.1	5	1.1	5	1.1	5
DCDC3	1.1	3	1.1	5	1.1	5	1.1	5
LDO1 <sup>(1)</sup>	1.8	15	1.8	15	1.8	15	1.8	15
LDO2	3.3	2	3.3	2	3.3	3	3.3	3
LS1/LDO3	Load switch	1	3.3 (LDO, 200 mA)	3	1.8 (LDO, 400 mA)	2	1.8 (LDO, 400 mA)	2
LS2/LDO4	Load switch	4	3.3 (LDO, 200 mA)	4	3.3 (LDO, 400 mA)	4	3.3 (LDO, 400 mA)	4

(1) Strobe 15 (LDO1) is the first rail to be enabled in a sequence, followed by strobe 1-7. See [Wake-Up and Power-Up Sequencing](#) for details.

## 7 Pin Configuration and Functions

**RSL Package  
48 Pins  
Top View**

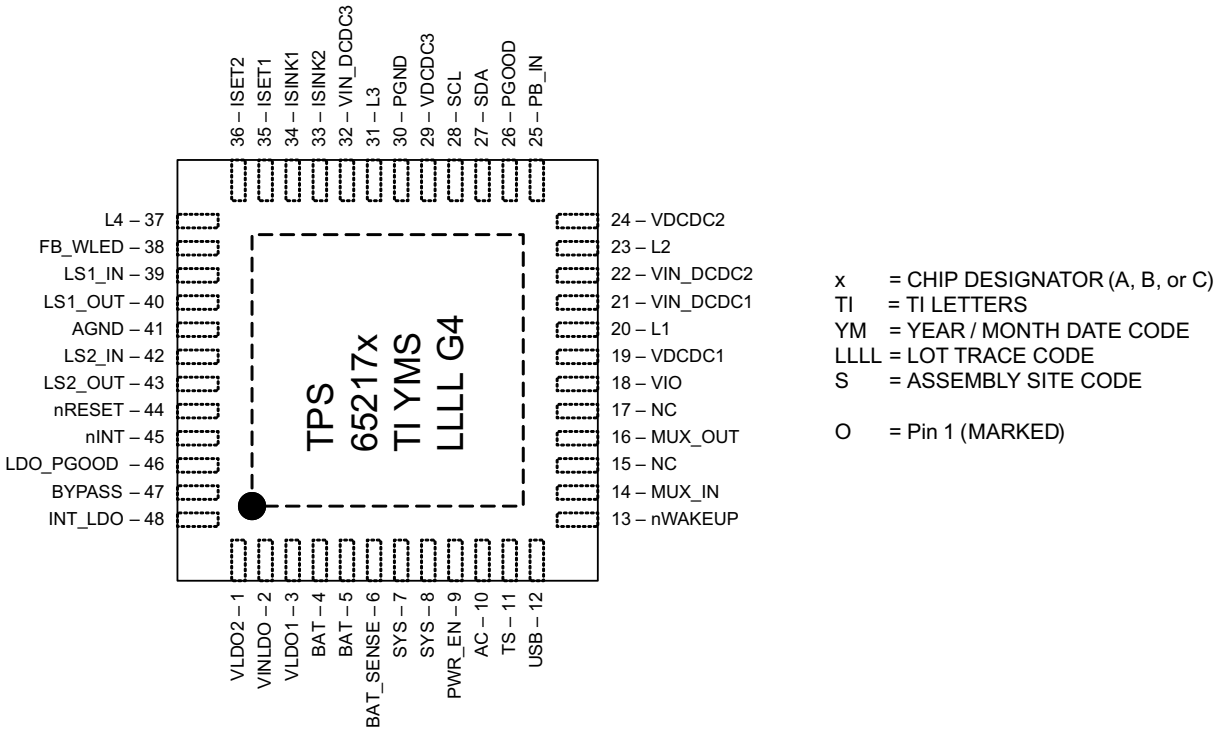

**Pin Functions**

PIN		I/O	DESCRIPTION
NAME	NO.		
AC	10	I	AC adapter input to power path. Connect to an external DC supply.
AGND	41	—	Analog GND, connect to PGND (PowerPad)
BAT	4, 5	I/O	Battery charger output. Connect to battery.
BAT_SENSE	6	I	Battery voltage sense input, connect to BAT directly at the battery terminal.
BYPASS	47	O	Internal bias voltage (2.25 V). It is not recommended to connect any external load to this pin.
FB_WLED	38	I	Feedback pin for WLED boost converter. Also connected to the Anode of the WLED strings.
INT_LDO	48	O	Internal bias voltage (2.30 V). It is not recommended to connect any external load to this pin.
ISET1	35	I	Low-level WLED current set. Connect a resistor to ground to set the WLED low-current level.
ISET2	36	I	High-level WLED current set. Connect a resistor to ground to set the WLED high-current level.
ISINK1	34	I	Input to the WLED current SINK1. Connect to the cathode of the WLED string. Current through SINK1 equals current through ISINK2. If only one WLED string is used, short ISINK1 and ISINK2 together.
ISINK2	33	I	Input to the WLED current SINK2. Connect to the cathode of the WLED string. Current through SINK2 equals current through ISINK2. If only one WLED string is used, short ISINK1 and ISINK2 together.
L1	20	O	Switch pin for DCDC1. Connect to inductor.
L2	23	O	Switch pin for DCDC2. Connect to inductor.
L3	31	O	Switch pin for DCDC3. Connect to Inductor.

**Pin Functions (continued)**

PIN		I/O	DESCRIPTION
NAME	NO.		
L4	37	O	Switch Pin of the WLED boost converter. Connected to Inductor.
LDO_PGOOD	46	O	LDO power good (LDO1 and LDO2 only, push/pull output). Pulled low when either LDO1 or LDO2 is out of regulation.
LS1_IN	39	I	Input voltage pin for load switch 1/LDO3
LS1_OUT	40	O	Output voltage pin for load switch 1/LDO3
LS2_IN	42	I	Input voltage pin for load switch 2/LDO4
LS2_OUT	43	O	Output voltage pin for load switch 2/LDO4
MUX_IN	14	O	Input to analog multiplexer
MUX_OUT	16	O	Output pin of analog multiplexer
NC	15		Not used
NC	17	—	Not used
nINT	45	O	Interrupt output (active low, open drain). Pin is pulled low if an interrupt bit is set. The output goes high after the bit causing the interrupt in register INT has been read. The interrupt sources can be masked in register INT, so no interrupt is generated when the corresponding interrupt bit is set.
nRESET	44	I	Reset pin (active low). Pull this pin low and the PMIC will shut down, and after 1s power-up in its default state.
nWAKEUP	13	O	Signal to host to indicate a power on event (active low, open-drain output)
PB_IN	25	I	Push-button monitor input. Typically connected to a momentary switch to ground (active low).
PGND	30		Power ground. Connect to ground plane.
PGOOD	26	O	Power-good output (push/pull output). Pulled low when any of the power rails are out of regulation. Behavior is register programmable.
PowerPad	—	—	Power ground connection for the PMU. Connect to GND
PWR_EN	9	I	Enable input for DCDC1, 2, 3 converters and LDO1, 2, 3, 4. Pull this pin high to start the power-up sequence.
SCL	28	I	Clock input for the I <sup>2</sup> C interface
SDA	27	I/O	Data line for the I <sup>2</sup> C interface
SYS	7, 8	O	System voltage pin and output of the power path. All voltage regulators are typically powered from this output.
TS	11	I	Temperature sense input. Connect to NTC thermistor to sense battery temperature. Works with 10k and 100k thermistors. See charger section for details.
USB	12	I	USB voltage input to power path. Connect to external voltage from a USB port.
VDCDC1	19	I	DCDC1 output/ feedback voltage sense input
VDCDC2	24	O	DCDC2 output/feedback voltage sense input
VDCDC3	29	O	DCDC3 output/feedback voltage sense input
VINLDO	2	I	Input voltage for LDO1 and LDO2
VIN_DCDC1	21	I	Input voltage for DCDC1. Must be connected to SYS pin.
VIN_DCDC2	22	I	Input voltage for DCDC2. Must be connected to SYS pin.
VIN_DCDC3	32	I	Input voltage for DCDC3. Must be connected to SYS pin.
VIO	18	I	Output-high supply for output buffers
VLDO1	3	O	Output voltage of LDO1
VLDO2	1	O	Output voltage of LDO2

## 8 Specifications

### 8.1 Absolute Maximum Ratings

over operating free-air temperature range (unless otherwise noted) <sup>(1)(2)</sup>

		MIN	MAX	UNIT
Supply voltage (with respect to PGND)	BAT	-0.3	7	V
	USB, AC	-0.3	20	
Input/Output voltage (with respect to PGND)	All pins unless specified separately	-0.3	7	V
	ISINK	-0.3	20	
	L4, FB_WLED	-0.3	44	
Absolute voltage difference between SYS and any VIN_DCDCx pin or SYS and VINLDO		0.3	0.3	V
Terminal current	SYS, USB, BAT	3000	3000	mA
Source or Sink current	PGOOD, LDO_PGOOD	6	6	mA
Sink current	nWAKEUP, nINT	2	2	mA
T <sub>J</sub>	Operating junction temperature	125	125	°C
T <sub>A</sub>	Operating ambient temperature	-40	105	°C
T <sub>stg</sub>	Storage temperature	-65	150	°C

- (1) Stresses beyond those listed under *Absolute Maximum Ratings* may cause permanent damage to the device. These are stress ratings only, which do not imply functional operation of the device at these or any other conditions beyond those indicated under *Recommended Operating Conditions*. Exposure to absolute-maximum-rated conditions for extended periods may affect device reliability.
- (2) All voltage values are with respect to network ground terminal.

### 8.2 ESD Ratings

		VALUE	UNIT
V <sub>(ESD)</sub>	Electrostatic discharge		
	Human-body model (HBM), per ANSI/ESDA/JEDEC JS-001 <sup>(1)</sup>	±2000	V
Charged-device model (CDM), per JEDEC specification JESD22-C101 <sup>(2)</sup>	±500		

- (1) JEDEC document JEP155 states that 500-V HBM allows safe manufacturing with a standard ESD control process.
- (2) JEDEC document JEP157 states that 250-V CDM allows safe manufacturing with a standard ESD control process.

### 8.3 Recommended Operating Conditions

Over operating free-air temperature range (unless otherwise noted)

	MIN	NOM	MAX	UNIT
Supply voltage, USB, AC	4.3		5.8	V
Supply voltage, BAT	2.75		5.5	V
Input current from AC			2.5	A
Input current from USB			1.3	A
Battery current			2	A
Input voltage range for DCDC1, DCDC2, and DCDC3	2.7		5.8	V
Input voltage range for LDO1, LDO2	1.8		5.8	V
Input voltage range for LS1/LDO, LS2/LDO4 configured as LDOs	2.7		5.8	V
Input voltage range for LS1/LDO, LS2/LDO4 configured as load switches	1.8		5.8	V
Output voltage range for LDO1	1.0		3.3	V
Output voltage range for LDO2	0.9		3.3	V
Output voltage range for LS1/LDO3, LS2/LDO4	1.8		3.3	V
Output current DCDC1	0		1.2	A
Output current DCDC2	0		1.2	A
Output current DCDC3	0		1.2	A
Output current LDO1, LDO2	0		100	mA

## Recommended Operating Conditions (continued)

Over operating free-air temperature range (unless otherwise noted)

		MIN	NOM	MAX	UNIT
Output current LS1/LDO3, LS2/LDO4 configured as LDOs	TPS65217A	0		200	mA
	TPS65217B	0		200	
	TPS65217C	0		400	
	TPS65217D	0		400	
Output current LS1/LDO, LS2/LDO4 configured as load switches		0		200	mA

## 8.4 Electrical Characteristics

 $V_{BAT} = 3.6\text{ V} \pm 5\%$ ,  $T_J = 27^\circ\text{C}$  (unless otherwise noted)

PARAMETER		TEST CONDITIONS		MIN	TYP	MAX	UNIT
<b>INPUT VOLTAGE AND CURRENTS</b>							
$V_{BAT}$	Battery input voltage range	USB or AC supply connected		0		5.5	V
		USB and AC not connected		2.75		5.5	
$V_{AC}$	AC adapter input voltage range	Valid range for charging		4.3		5.8	V
$V_{USB}$	USB input voltage range	Valid range for charging		4.3		5.8	V
$V_{UVLO}$	Under voltage lock-out	Measured in respect to $V_{BAT}$ ; supply falling; $V_{AC} = V_{USB} = 0\text{ V}$	UVLO[1:0] = 00		2.73		V
			UVLO[1:0] = 01		2.89		
			UVLO[1:0] = 10		3.18		
			UVLO[1:0] = 11		3.3		
	Accuracy			-2%		2%	
	Deglintch time	Not tested in production		4		6	ms
$V_{OFFSET}$	AC/USB UVLO offset	$V_{BAT} < V_{UVLO}$ ; Device shuts down when $V_{AC}$ , $V_{USB}$ drop below $V_{UVLO} + V_{OFFSET}$			200		mV
$I_{OFF}$	OFF current, Total current into VSYS, VINDCDCx, VINLDO	All rails disabled, $T_A = 27^\circ\text{C}$			6		$\mu\text{A}$
$I_{SLEEP}$	Sleep current, Total current into VSYS, VINDCDCx, VINLDO	LDO1 and LDO2 enabled, no load. All other rails disabled. $V_{SYS} = 4\text{ V}$ , $T_A = 0.105^\circ\text{C}$			80	106	$\mu\text{A}$
<b>POWER PATH USB/AC DETECTION LIMITS</b>							
$V_{IN(DT)}$	AC/USB voltage detection threshold	$V_{BAT} > V_{UVLO}$	AC/USB valid when $V_{AC/USB} - V_{BAT} > V_{IN(DT)}$	190			mV
		$V_{BAT} < V_{UVLO}$	AC/USB valid when $V_{AC/USB} > V_{IN(DT)}$	4.3			V
$V_{IN(NDT)}$	AC/USB voltage removal detection threshold	$V_{BAT} > V_{UVLO}$	AC/USB invalid when $V_{AC/USB} - V_{BAT} < V_{IN(NDT)}$			125	mV
		$V_{BAT} < V_{UVLO}$	AC/USB invalid when $V_{AC/USB} < V_{IN(NDT)}$		$V_{UVLO} + V_{OFFSET}$		V
$T_{RISE}$	$V_{AC}$ , $V_{USB}$ rise time	Voltage rising from 100 mV to 4.5 V. If rise time is exceeded, device may not power-up.				50	ms
$T_{DG(DT)}$	Power detected deglitch	AC or USB voltage increasing; Not tested in production			22.5		ms
$V_{IN(OVP)}$	Input over voltage detection threshold	USB and AC input		5.8	6	6.4	V
<b>POWER PATH TIMING</b>							
$T_{SW(PSEL)}$	Switching from AC to USB	Not tested in production				150	$\mu\text{s}$
<b>POWER PATH MOSFET CHARACTERISTICS</b>							
$V_{DO, AC}$	AC input switch dropout voltage	$I_{AC}[1:0] = 11$ (2.5 A), $I_{SYS} = 1\text{ A}$			150		mV
$V_{DO, USB}$	USB input switch dropout voltage	$I_{USB}[1:0] = 01$ (500 mA), $I_{SYS} = 500\text{ mA}$			100		mV
		$I_{USB}[1:0] = 10$ (1300 mA), $I_{SYS} = 800\text{ mA}$			160		
$V_{DO, BAT}$	Battery switch dropout voltage	$V_{BAT} = 3\text{ V}$ , $I_{BAT} = 1\text{ A}$			60		mV

**Electrical Characteristics (continued)**
 $V_{BAT} = 3.6\text{ V} \pm 5\%$ ,  $T_J = 27^\circ\text{C}$  (unless otherwise noted)

PARAMETER		TEST CONDITIONS	MIN	TYP	MAX	UNIT
<b>POWER PATH INPUT CURRENT LIMITS</b>						
$I_{ACLMT}$	Input current limit; AC pin	IAC[1:0] = 00	90		130	mA
		IAC[1:0] = 01	480		580	
		IAC[1:0] = 10	1000	1500		
		IAC[1:0] = 11	2000	2500		
$I_{USBLMT}$	Input current limit; USB pin	IUSB[1:0] = 00	90		100	mA
		IUSB[1:0] = 01	460		500	
		IUSB[1:0] = 10	1000	1300		
		IUSB[1:0] = 11	1500	1800		
$I_{BAT}$	Battery load current	Not tested in production			2	A
<b>POWER PATH BATTERY SUPPLEMENT DETECTION</b>						
$V_{BSUP}$	Battery supplement threshold	$V_{SYS} \leq V_{BAT} - V_{BSUP1}$ , $V_{SYS}$ falling IUSB[1:0] = 10		40		mV
	Hysteresis	$V_{SYS}$ rising		20		
<b>POWER PATH BATTERY PROTECTION</b>						
$V_{BAT(SC)}$	BAT pin short-circuit detection threshold		1.3	1.5	1.7	V
$I_{BAT(SC)}$	Source current for BAT pin short-circuit detection			7.5		mA
<b>INPUT BASED DYNAMIC POWER MANAGEMENT</b>						
$V_{DPM}$	Threshold at which DPPM loop is enabled	$I^2C$ selectable	3.5		4.25	V
<b>BATTERY CHARGER</b>						
$V_{OREG}$	Battery charger voltage	$I^2C$ selectable	4.10		4.25	V
	Accuracy		-2%		1%	
$V_{LOWV}$	Pre-charge to fast-charge transition threshold	VPRECHG = 0		2.9		V
		VPRECHG = 1		2.5		
$t_{DGL1(LOWV)}$	Deglintch time on pre-charge to fast-charge transition	Not tested in production		25		ms
$t_{DGL2(LOWV)}$	Deglintch time on fast-charge to pre-charge transition	Not tested in production		25		ms
$I_{CHG}$	Battery fast charge current range $V_{OREG} > V_{BAT} > V_{LOWV}$ , $V_{IN} = V_{USB} = 5\text{ V}$	ICHRG[1:0] = 00		300		mA
		ICHRG[1:0] = 01		400		
		ICHRG[1:0] = 10	450	500	550	
		ICHRG[1:0] = 11		700		
$I_{PRECHG}$	Pre-charge current	ICHRG[1:0] = 00		30		mA
		ICHRG[1:0] = 01		40		
		ICHRG[1:0] = 10	25	50	75	
		ICHRG[1:0] = 11		70		
$I_{TERM}$	Charge current value for termination detection threshold (fraction of $I_{CHG}$ )	TERMIF[1:0] = 00		2.5%		
		TERMIF[1:0] = 01	3%	7.5%	10%	
		TERMIF[1:0] = 10		15%		
		TERMIF[1:0] = 11		18%		
$t_{DGL(TERM)}$	Deglintch time, termination detected	Not tested in production		125		ms
$V_{RCH}$	Recharge detection threshold	Voltage below $V_{OREG}$	150	100	70	mV
$t_{DGL(RCH)}$	Deglintch time, recharge threshold detected	Not tested in production		125		ms
$I_{BAT(DET)}$	Sink current for battery detection	$T_J = 27^\circ\text{C}$	3	7.5	10	mA
$t_{DET}$	Battery detection timer. $I_{BAT(DET)}$ is pulled from the battery for $t_{DET}$ . If BAT voltage remains above $V_{RCH}$ threshold the battery is connected.	$V_{BAT} < V_{RCH}$ ; Not tested in production		250		ms



## Electrical Characteristics (continued)

 $V_{BAT} = 3.6\text{ V} \pm 5\%$ ,  $T_J = 27^\circ\text{C}$  (unless otherwise noted)

PARAMETER		TEST CONDITIONS	MIN	TYP	MAX	UNIT
$T_{CHG}$	Charge safety timer	Safety timer range, thermal and DPM not active, selectable by I <sup>2</sup> C; Not tested in production	4		8	h
$T_{PRECHG}$	Precharge timer	Pre charge timer, thermal and DPM/DPPM loops not active, selectable by I <sup>2</sup> C; Not tested in production	PCHRG = 0	30	60	min
			PCHRG = 1	60		
<b>BATTERY NTC MONITOR</b>						
$T_{THON}$	Thermistor power on time at charger off, sampling mode on			10		ms
$T_{THOFF}$	Thermistor power sampling period at charger off, sampling mode on			1		s
$R_{NTC\_PULL}$	Pull-up resistor from thermistor to Internal LDO . I2C selectable	NTC_TYPE = 1 (10k NTC)		7.35		k $\Omega$
		NTC_TYPE = 0 (100K NTC)		60.5		
	Accuracy	$T_A = 27^\circ\text{C}$	-3%		3%	
$V_{LTF}$	Low temp failure threshold	Temperature falling		1660		mV
		Temperature rising		1610		
$V_{HTF}$	High temp failure threshold	Temperature falling	TRANGE = 0	910		mV
		Temperature rising		860		
		Temperature falling	TRANGE = 1	667		
		Temperature rising		622		
$V_{DET}$	Thermistor detection threshold		1750		1850	mV
$t_{BATDET}$	Thermistor not detected. Battery not present deglitch.	Not tested in production		26		ms
<b>THERMAL REGULATION</b>						
$T_{J(REG)}$	Temperature regulation limit	Temperature at which charge current is reduced	111		123	$^\circ\text{C}$
<b>DCDC1 (BUCK)</b>						
$V_{IN}$	Input voltage range	VIN_DCDC1 pin	2.7		$V_{SYS}$	V
$I_{Q,SLEEP}$	Quiescent current in SLEEP mode	No load, $V_{SYS} = 4\text{ V}$ , $T_A = 25^\circ\text{C}$		30		$\mu\text{A}$
$V_{OUT}$	Output voltage range	External resistor divider (XADJ1 = 1)	0.6		$V_{IN}$	V
		I <sup>2</sup> C selectable in 25-mV steps (XADJ1 = 0)	0.9		1.8 <sup>(1)</sup>	
	DC output voltage accuracy	$V_{IN} = V_{OUT} + 0.3\text{ V}$ to 5.8 V; $0\text{ mA} \leq I_{OUT} \leq 1.2\text{ A}$	-2%		3%	
	Power save mode (PSM) ripple voltage	$I_{OUT} = 1\text{ mA}$ , PFM mode $L = 2.2\text{ }\mu\text{H}$ , $C_{OUT} = 20\text{ }\mu\text{F}$		40		mV <sub>pp</sub>
$I_{OUT}$	Output current range		0		1.2	A
$R_{DS(ON)}$	High side MOSFET on-resistance	$V_{IN} = 2.7\text{ V}$		170		m $\Omega$
	Low side MOSFET on-resistance	$V_{IN} = 2.7\text{ V}$		120		
$I_{LEAK}$	High side MOSFET leakage current	$V_{IN} = 5.8\text{ V}$			2	$\mu\text{A}$
	Low side MOSFET leakage current	$V_{DS} = 5.8\text{ V}$			1	
$I_{LIMIT}$	Current limit (high and low side MOSFET).	$2.7\text{ V} < V_{IN} < 5.8\text{ V}$		1.6		A
$f_{SW}$	Switching frequency		1.95	2.25	2.55	MHz
$V_{FB}$	Feedback voltage	XADJ = 1		600		mV
$t_{SS}$	Soft-start time	Time to ramp $V_{OUT}$ from 5% to 95%, no load		750		$\mu\text{s}$
$R_{DIS}$	Internal discharge resistor at L1 <sup>(2)</sup>			250		$\Omega$
L	Inductor		1.5	2.2		$\mu\text{H}$
$C_{OUT}$	Output capacitor	Ceramic	10	22		$\mu\text{F}$
	ESR of output capacitor			20		m $\Omega$

(1) Contact factory for 3.3-V option.

(2) Can be factory disabled.

**Electrical Characteristics (continued)**
 $V_{BAT} = 3.6\text{ V} \pm 5\%$ ,  $T_J = 27^\circ\text{C}$  (unless otherwise noted)

PARAMETER		TEST CONDITIONS	MIN	TYP	MAX	UNIT
<b>DCDC2 (BUCK)</b>						
$V_{IN}$	Input voltage range	VIN_DCDC2 pin	2.7		$V_{SYS}$	V
$I_{Q,SLEEP}$	Quiescent current in SLEEP mode	No load, $V_{SYS} = 4\text{ V}$ , $T_A = 25^\circ\text{C}$		30		$\mu\text{A}$
$V_{OUT}$	Output voltage range	External resistor divider (XADJ2 = 1)	0.6		$V_{IN}$	V
		$I^2\text{C}$ selectable in 25-mV steps (XADJ2 = 0)	0.9		3.3	
	DC output voltage accuracy	$V_{IN} = V_{OUT} + 0.3\text{ V}$ to 5.8 V; $0\text{ mA} \leq I_{OUT} \leq 1.2\text{ A}$	-2%		3%	
	Power save mode (PSM) ripple voltage	$I_{OUT} = 1\text{ mA}$ , PFM mode $L = 2.2\text{ }\mu\text{H}$ , $C_{OUT} = 20\text{ }\mu\text{F}$		40		mV <sub>pp</sub>
$I_{OUT}$	Output current range		0		1.2	A
$R_{DS(ON)}$	High side MOSFET on-resistance	$V_{IN} = 2.7\text{ V}$		170		m $\Omega$
	Low side MOSFET on-resistance	$V_{IN} = 2.7\text{ V}$		120		
$I_{LEAK}$	High side MOSFET leakage current	$V_{IN} = 5.8\text{ V}$			2	$\mu\text{A}$
	Low side MOSFET leakage current	$V_{DS} = 5.8\text{ V}$			1	
$I_{LIMIT}$	Current limit (high and low side MOSFET).	$2.7\text{ V} < V_{IN} < 5.8\text{ V}$		1.6		A
$f_{SW}$	Switching frequency		1.95	2.25	2.55	MHz
$V_{FB}$	Feedback voltage	XADJ = 1		600		mV
$t_{SS}$	Soft-start time	Time to ramp $V_{OUT}$ from 5% to 95%, no load		750		$\mu\text{s}$
$R_{DIS}$	Internal discharge resistor at L2			250		$\Omega$
L	Inductor		1.5	2.2		$\mu\text{H}$
$C_{OUT}$	Output capacitor	Ceramic	10	22		$\mu\text{F}$
	ESR of output capacitor			20		m $\Omega$
<b>DCDC3 (BUCK)</b>						
$V_{IN}$	Input voltage range	VIN_DCDC3 pin	2.7		$V_{SYS}$	V
$I_{Q,SLEEP}$	Quiescent current in SLEEP mode	No load, $V_{SYS} = 4\text{ V}$ , $T_A = 25^\circ\text{C}$		30		$\mu\text{A}$
$V_{OUT}$	Output voltage range	External resistor divider (XADJ3 = 1)	0.6		$V_{IN}$	V
		$I^2\text{C}$ selectable in 25-mV steps (XADJ3 = 0)	0.9		1.5 <sup>(1)</sup>	
	DC output voltage accuracy	$V_{IN} = V_{OUT} + 0.3\text{ V}$ to 5.8 V; $0\text{ mA} \leq I_{OUT} \leq 1.2\text{ A}$	-2%		3%	
	Power save mode (PSM) ripple voltage	$I_{OUT} = 1\text{ mA}$ , PFM mode $L = 2.2\text{ }\mu\text{H}$ , $C_{OUT} = 20\text{ }\mu\text{F}$		40		mV <sub>pp</sub>
$I_{OUT}$	Output current range		0		1.2	A
$R_{DS(ON)}$	High side MOSFET on-resistance	$V_{IN} = 2.7\text{ V}$		170		m $\Omega$
	Low side MOSFET on-resistance	$V_{IN} = 2.7\text{ V}$		120		
$I_{LEAK}$	High side MOSFET leakage current	$V_{IN} = 5.8\text{ V}$			2	$\mu\text{A}$
	Low side MOSFET leakage current	$V_{DS} = 5.8\text{ V}$			1	
$I_{LIMIT}$	Current limit (high and low side MOSFET).	$2.7\text{ V} < V_{IN} < 5.8\text{ V}$		1.6		A
$f_{SW}$	Switching frequency		1.95	2.25	2.55	MHz
$V_{FB}$	Feedback voltage	XADJ = 1		600		mV
$t_{SS}$	Soft-start time	Time to ramp $V_{OUT}$ from 5% to 95%, no load		750		$\mu\text{s}$
$R_{DIS}$	Internal discharge resistor at L1, L2			250		$\Omega$
L	Inductor		1.5	2.2		$\mu\text{H}$
$C_{OUT}$	Output capacitor	Ceramic	10	22		$\mu\text{F}$
	ESR of output capacitor			20		m $\Omega$

**Electrical Characteristics (continued)**
 $V_{BAT} = 3.6\text{ V} \pm 5\%$ ,  $T_J = 27^\circ\text{C}$  (unless otherwise noted)

PARAMETER		TEST CONDITIONS	MIN	TYP	MAX	UNIT
<b>LDO1, LDO2</b>						
$V_{IN}$	Input voltage range		1.8		5.8	V
$I_{Q,SLEEP}$	Quiescent current in SLEEP mode	No load, $V_{SYS} = 4\text{ V}$ , $T_A = 25^\circ\text{C}$		5		$\mu\text{A}$
$V_{OUT}$	Output voltage range	LDO1, I <sup>2</sup> C selectable	1.0		3.3	V
		LDO2, I <sup>2</sup> C selectable	0.9		3.3	
	DC output voltage accuracy	$I_{OUT} = 10\text{ mA}$ , $V_{IN} > V_{OUT} + 200\text{ mV}$ , $V_{OUT} > 0.9\text{ V}$	-2%		2%	
	Line regulation	$V_{IN} = 2.7\text{ V} - 5.5\text{ V}$ , $V_{OUT} = 1.2\text{ V}$ , $I_{OUT} = 100\text{ mA}$	-1%		1%	
	Load regulation	$I_{OUT} = 1\text{ mA} - 100\text{ mA}$ , $V_{OUT} = 1.2\text{ V}$ , $V_{IN} = 3.3\text{ V}$	-1%		1%	
$I_{OUT} = 0\text{ mA} - 1\text{ mA}$ , $V_{OUT} = 1.2\text{ V}$ , $V_{IN} = 3.3\text{ V}$		-2.5%		2.5%		
$I_{OUT}$	Output current range	Sleep state	0		1	mA
		Active state	0		100	
$I_{SC}$	Short circuit current limit	Output shorted to GND	100	250		mA
$V_{DO}$	Dropout voltage	$I_{OUT} = 100\text{ mA}$ , $V_{IN} = 3.3\text{ V}$			200	mV
$R_{DIS}$	Internal discharge resistor at output			430		$\Omega$
$C_{OUT}$	Output capacitor	Ceramic		2.2		$\mu\text{F}$
	ESR of output capacitor			20		m $\Omega$
<b>LS1/LDO3 AND LS2/LDO4, CONFIGURED AS LDOs</b>						
$V_{IN}$	Input voltage range		2.7		5.8	V
$I_{Q,SLEEP}$	Quiescent current in SLEEP mode	No load, $V_{SYS} = 4\text{ V}$ , $T_A = 25^\circ\text{C}$		30		$\mu\text{A}$
$V_{OUT}$	Output voltage range	LS1LDO3 = 1, LS2LDO4 = 1 I <sup>2</sup> C selectable	1.5		3.3	V
		DC output voltage accuracy	$I_{OUT} = 10\text{ mA}$ , $V_{IN} > V_{OUT} + 200\text{ mV}$ , $V_{OUT} > 1.8\text{ V}$	-2%		
	Line regulation	$V_{IN} = 2.7\text{ V} - 5.5\text{ V}$ , $V_{OUT} = 1.8\text{ V}$ , $I_{OUT} = 200\text{ mA}$	-1%		1%	
	Load regulation	$I_{OUT} = 1\text{ mA} - 200\text{ mA}$ , $V_{OUT} = 1.8\text{ V}$ , $V_{IN} = 3.3\text{ V}$	-1%		1%	
$I_{OUT}$	Output current range	TPS65217A	0		200	mA
		TPS65217B	0		200	
		TPS65217C	0		400	
		TPS65217D	0		400	
$I_{SC}$	Short circuit current limit	Output shorted to GND	TPS65217A	200	280	mA
			TPS65217B	200	280	
			TPS65217C	400	480	
			TPS65217D	400	480	
$V_{DO}$	Dropout voltage	$I_{OUT} = 200\text{ mA}$ , $V_{IN} = 3.3\text{ V}$			200	mV
$R_{DIS}$	Internal discharge resistor at output <sup>(2)</sup>			375		$\Omega$
$C_{OUT}$	Output capacitor	Ceramic	8	10	12	$\mu\text{F}$
	ESR of output capacitor			20		m $\Omega$
<b>LS1/LDO3 AND LS2/LDO4, CONFIGURED AS LOAD SWITCHES</b>						
$V_{IN}$	Input voltage range	LS1_VIN, LS2_VIN pins	1.8		5.8	V
$R_{DS(ON)}$	P-channel MOSFET on-resistance	$V_{IN} = 1.8\text{ V}$ , over full temperature range		300	650	m $\Omega$
$I_{SC}$	Short circuit current limit	Output shorted to GND	200	280		mA
$R_{DIS}$	Internal discharge resistor at output			375		$\Omega$
$C_{OUT}$	Output capacitor	Ceramic	1	10	12	$\mu\text{F}$
	ESR of output capacitor			20		m $\Omega$
<b>WLED BOOST</b>						
$V_{IN}$	Input voltage range		2.7		5.8	V

**Electrical Characteristics (continued)**
 $V_{BAT} = 3.6\text{ V} \pm 5\%$ ,  $T_J = 27^\circ\text{C}$  (unless otherwise noted)

PARAMETER		TEST CONDITIONS	MIN	TYP	MAX	UNIT	
$V_{OUT}$	Max output voltage	$I_{SINK} = 20\text{ mA}$	32			V	
$V_{OVP}$	Output over-voltage protection		37	38	39	V	
$R_{DS(ON)}$	N-channel MOSFET on-resistance	$V_{IN} = 3.6\text{ V}$		0.6		$\Omega$	
$I_{LEAK}$	N-channel leakage current	$V_{DS} = 25\text{ V}$ , $T_A = 25^\circ\text{C}$		2		$\mu\text{A}$	
$I_{LIMIT}$	N-channel MOSFET current limit			1.6	1.9	A	
$f_{SW}$	Switching frequency			1.125		MHz	
$I_{INRUSH}$	Inrush current on start-up	$V_{IN} = 3.6\text{ V}$ , 1% duty cycle setting		1.1		A	
		$V_{IN} = 3.6\text{ V}$ , 100% duty cycle setting		2.1			
L	Inductor			18		$\mu\text{H}$	
$C_{OUT}$	Output capacitor	Ceramic		4.7		$\mu\text{F}$	
	ESR of output capacitor			20		m $\Omega$	
<b>WLED CURRENT SINK1, SINK2</b>							
$V_{SINK1,2}$	Over-voltage protection threshold at ISINK1, ISINK2 pins				19	V	
$V_{DO, SINK1,2}$	Current sink drop-out voltage	Measured from ISINK to GND		400		mV	
$V_{ISET1,2}$	ISET1, ISET2 pin voltage			1.24		V	
$I_{SINK1,2}$	WLED current range (ISINK1, ISINK2)		1		25	mA	
		WLED sink current	$R_{ISET} = 130.0\text{ k}\Omega$		10		
	$R_{ISET} = 86.6\text{ k}\Omega$			15			
	$R_{ISET} = 64.9\text{ k}\Omega$			20			
	$R_{ISET} = 52.3\text{ k}\Omega$			25			
	DC current set accuracy	$I_{SINK} = 5\text{ mA to } 25\text{ mA}$ , 100% duty cycle		-5%			5%
DC current matching		$R_{SET1} = 52.3\text{ k}\Omega$ , $I_{SINK} = 25\text{ mA}$ , $V_{BAT} = 3.6\text{ V}$ , 100% duty cycle		-5%		5%	
		$R_{SET1} = 130\text{ k}\Omega$ , $I_{SINK} = 10\text{ mA}$ , $V_{BAT} = 3.6\text{ V}$ , 100% duty cycle		-5%		5%	
$f_{PWM}$	PWM dimming frequency	FDIM[1:0] = 00		100		Hz	
		FDIM[1:0] = 01		200			
		FDIM[1:0] = 10		500			
		FDIM[1:0] = 11		1000			
<b>ANALOG MULTIPLEXER</b>							
g	Gain, VBAT, VSYS	$V_{BAT}/V_{OUT,MUX}$ ; $V_{SYS}/V_{OUT,MUX}$		3		V/V	
	Gain, VTS, MUX_IN	$V_{TS}/V_{OUT,MUX}$ ; $V_{MUX\_IN}/V_{MUX\_OUT}$		1			
	Gain, VICHARGE	$V_{OUT,MUX}/V_{ICHARGE}$	ICHRG[1:0] = 00b		7.575		V/A
			ICHRG[1:0] = 01b		5.625		
			ICHRG[1:0] = 10b		4.500		
ICHRG[1:0] = 11b		3.214					
$V_{OUT}$	Buffer headroom	$V_{SYS} - V_{MUX\_OUT}$ , $V_{SYS} = 3.6\text{ V}$ , MUX[2:0] = 101 ( $V_{MUX\_IN} - V_{MUX\_OUT}$ )/ $V_{MUX\_IN} > 1\%$		0.7	1	V	
$R_{OUT}$	Output Impedance			180		$\Omega$	
$I_{LEAK}$	Leakage current	MUX[2:0] = 000 (HiZ), $V_{MUX} = 2.25\text{ V}$			1	$\mu\text{A}$	
<b>LOGIC LEVELS AND TIMING CHARACTERISTICS (SCL, SDA, PB_IN, PGOOD, LDO_PGOOD, PWR_EN, nINT, nWAKEUP, nRESET)</b>							
$P_{GTH}$	PGOOD comparator threshold, All DCDC converters and LDOs	Output voltage falling, % of set voltage (not tested in production)		90%			
		Output voltage rising, % of set voltage (not production tested)		95%			
$P_{GDG}$	PGOOD deglitch time	Output voltage falling, DCDC1, 2, 3		2	4	ms	
		Output voltage falling, LDO1, 2, 3, 4		1	2		

**Electrical Characteristics (continued)**
 $V_{BAT} = 3.6\text{ V} \pm 5\%$ ,  $T_J = 27^\circ\text{C}$  (unless otherwise noted)

PARAMETER		TEST CONDITIONS		MIN	TYP	MAX	UNIT
$P_{GDLY}$	PGOOD delay time	PGDLY[1:0] = 00			20		ms
		PGDLY[1:0] = 01			100		
		PGDLY[1:0] = 10			200		
		PGDLY[1:0] = 11			400		
$t_{HRST}$	PB-IN "Hard Reset Detect" time	Not tested in production			8		s
$t_{DG}$	PB_IN pin deglitch time	Not tested in production			50		ms
	PWR_EN pin deglitch time	Not tested in production			50		
	nRESET pin deglitch time	Not tested in production			30		
$R_{PULLUP}$	PB_IN internal pull-up resistor				100		k $\Omega$
	nRESET internal pull-up resistor				100		
$V_{IH}$	High level input voltage PB_IN, SCL, SDA, PWR_EN, nRESET			1.2		$V_{IN}$	V
$V_{IL}$	Low level input voltage PB_IN, SCL, SDA, PWR_EN, nRESET			0		0.4	V
$I_{BIAS}$	Input bias current PB_IN, SCL, SDA				0.01	1	$\mu\text{A}$
$V_{OL}$	Output low voltage	nINT, nWAKEUP	$I_O = 1\text{ mA}$			0.3	V
		PGOOD, LDO_PGOOD	$I_O = 1\text{ mA}$			0.3	
$V_{OH}$	Output high voltage	PGOOD, LDO_PGOOD	$I_O = 1\text{ mA}$	$V_{IO} - 0.3$			V
$I_{LEAK}$	Pin leakage current nINT, nWAKEUP	Pin pulled up to 3.3-V supply				0.2	$\mu\text{A}$
	I <sup>2</sup> C slave address				0x24h		
<b>OSCILLATOR</b>							
$f_{OSC}$	Oscillator frequency				9		MHz
	Frequency accuracy	$T_A = -40^\circ\text{C}$ to $105^\circ\text{C}$		-10%		10%	
<b>OVER TEMPERATURE SHUTDOWN</b>							
$T_{OTS}$	Over temperature shutdown	Increasing junction temperature			150		$^\circ\text{C}$
	Hysteresis	Decreasing junction temperature			20		$^\circ\text{C}$

## 8.5 Timing Requirements

 $V_{BAT} = 3.6 V \pm 5\%$ ,  $T_A = 25^\circ C$ ,  $C_L = 100 pF$  (unless otherwise noted)

		MIN	NOM	MAX	UNIT
$f_{SCL}$	Serial clock frequency	100		400	kHz
$t_{HD;STA}$	Hold time (repeated) START condition. After this period, the first clock pulse is generated	SCL = 100 KHz	4		$\mu s$
		SCL = 400 KHz	600		ns
$t_{LOW}$	LOW period of the SCL clock	SCL = 100 KHz	4.7		$\mu s$
		SCL = 400 KHz	1.3		
$t_{HIGH}$	HIGH period of the SCL clock	SCL = 100 KHz	4		$\mu s$
		SCL = 400 KHz	600		ns
$t_{SU;STA}$	Set-up time for a repeated START condition	SCL = 100 KHz	4.7		$\mu s$
		SCL = 400 KHz	600		ns
$t_{HD;DAT}$	Data hold time	SCL = 100 KHz	0	3.45	$\mu s$
		SCL = 400 KHz	0	900	ns
$t_{SU;DAT}$	Data set-up time	SCL = 100 KHz	250		ns
		SCL = 400 KHz	100		
$t_r$	Rise time of both SDA and SCL signals	SCL = 100 KHz		1000	ns
		SCL = 400 KHz		300	
$t_f$	Fall time of both SDA and SCL signals	SCL = 100 KHz		300	ns
		SCL = 400 KHz		300	
$t_{SU;STO}$	Set-up time for STOP condition	SCL = 100 KHz	4		$\mu s$
		SCL = 400 KHz	600		ns
$t_{BUF}$	Bus free time between stop and start condition	SCL = 100 KHz	4.7		$\mu s$
		SCL = 400 KHz	1.3		
$t_{SP}$	Pulse width of spikes which must be suppressed by the input filter	SCL = 100 KHz	N/A	N/A	ns
		SCL = 400 KHz	0	50	
$C_b$	Capacitive load for each bus line	SCL = 100 KHz		400	pF
		SCL = 400 KHz		400	

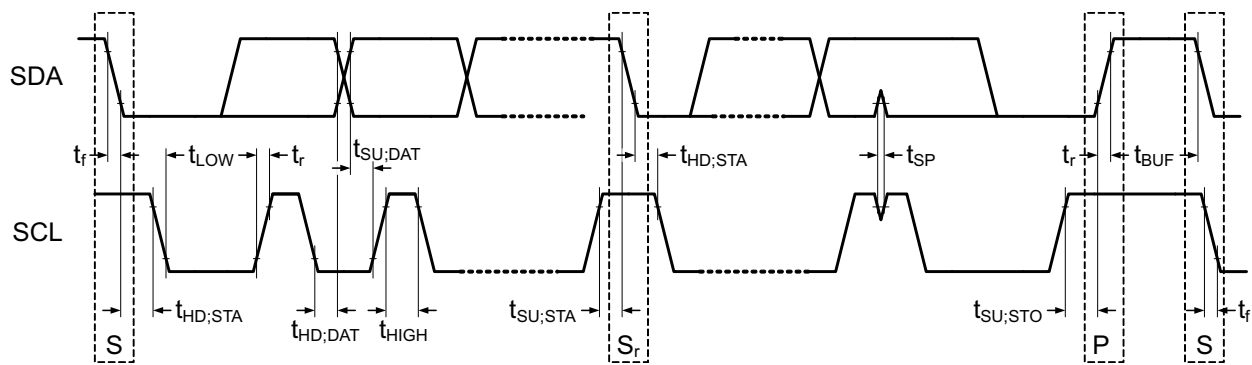
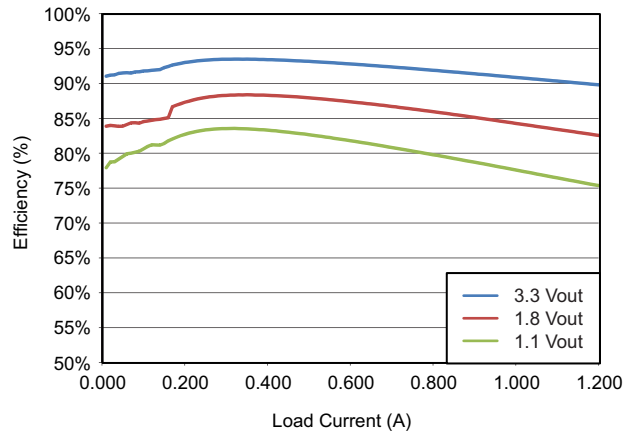

Figure 1. I<sup>2</sup>C Data Transmission Timing

### 8.6 Typical Characteristics



**Figure 2. TPS65217 DC-DC Efficiency 5 V in and LQM2HPN2R2MG0L Inductor**

## 9 Detailed Description

### 9.1 Overview

The TPS65217 provides three step-down converters, two LDOs, two load switches, a linear battery charger, white LED driver, and power path. The system can be supplied by any combination of USB port, 5-V AC adaptor, or Li-Ion battery. The device is characterized across a -40°C to 105°C temperature range, making it suitable for portable and non-portable 5-V industrial applications.

The I<sup>2</sup>C interface provides comprehensive features for using the TPS65217. All rails, load switches, and LDOs can be enabled or disabled. Power-up and power-down sequences can also be programmed through the I<sup>2</sup>C interface, as well as overtemperature and overcurrent thresholds. Charging and dimming parameters can also be monitored by the I<sup>2</sup>C interface.

The three 2.25-MHz step-down converters can each supply up to 1.2 A of current. The default output voltages for each converter can be adjusted through the I<sup>2</sup>C interface. All three converters feature dynamic voltage positioning to reduce the voltage undershoots and overshoots. Typically, the converters work at a fixed-frequency pulse width modulation (PWM) at moderate to heavy load currents. At light load currents the converters automatically enter power save mode and operate in PFM (Pulse Frequency Modulation); however, for low-noise application the device can be forced into fixed-frequency PWM using the I<sup>2</sup>C interface.

There are two traditional LDOs: LDO1 and LDO2. There are also two load switches, which can also be configured as LDOs: LDO3 and LDO4. LDO1 and LDO2 can support up to 100 mA each, but in SLEEP mode they are limited to 1 mA to reduce quiescent current. LDO3 and LDO4 can support up to 200 mA (TPS65217B), or 400 mA (TPS65217C/D). LDO1 is always ON, but any rail can be configured to remain up in SLEEP state.

Two power-good logic signals are provided; the main power-good, which monitors DCDC1, DCDC2, DCDC3, LS1/LDO3, and LS2/LDO4; if the load switches are configured as LDOs. The main power-good signal can be configured to monitor LDO1 and LDO2. This signal is high in ACTIVE state, but low in SLEEP, RESET, and OFF state. The LDO\_power-good monitors LDO1, and LDO2; the signal is high in ACTIVE and SLEEP state, but low in RESET or OFF state. The signals are both pulled low when all the monitored rails are pulled low or when one or more of the monitored rails are enabled and have encountered a fault, typically output short or overcurrent condition.

The highly-efficient boost converter has two current sinks capable of driving two strings of up to 10 LEDs 25 mA each, or a single sting of 20 LEDs at 50 mA. Brightness and dimming is supported by an internal PWM signal and I<sup>2</sup>C control; both current sources are controlled together and cannot operate independently.

The triple system power path allows for simultaneous and independent charging from the linear battery charger for single-cell Li-ion and Li-Polymer batteries, and powering of the system. The AC input is prioritized over USB as the power source for charging the battery and powering the system. Both these sources are prioritized over the battery for powering the system to reduce the number of charge and discharge cycles on the battery.



## 9.2 Functional Block Diagram

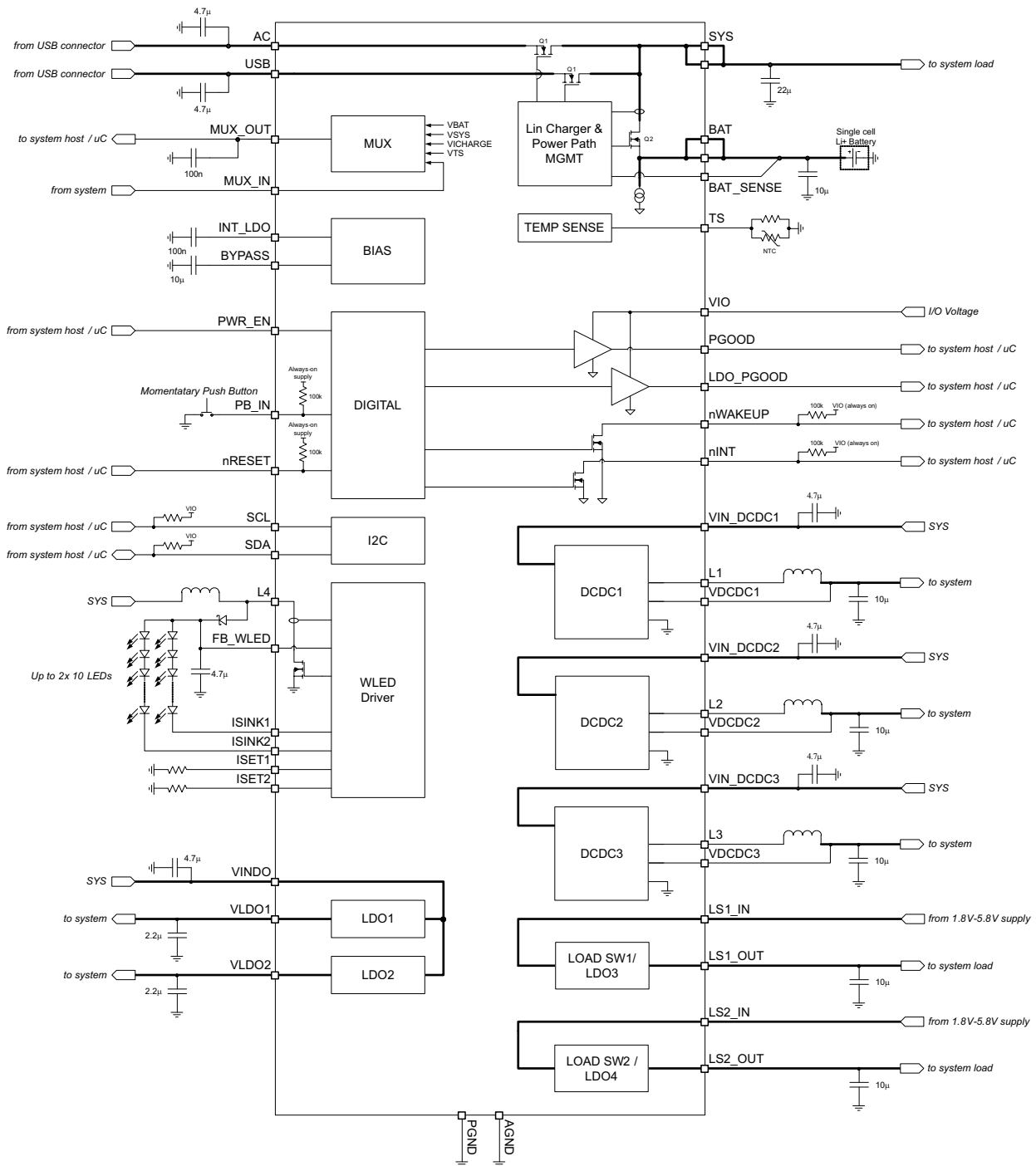

### 9.3 Feature Description

#### 9.3.1 Wake-Up and Power-Up Sequencing

The TPS65217 has a pre-defined power-up / power-down sequence which in a typical application does not need to be changed. However, it is possible to define custom sequences under I<sup>2</sup>C control. The power-up sequence is defined by strobes and delay times. Each output rail is assigned to a strobe to determine the order in which the rails are enabled and the delay times between strobes are selectable in a range from 1 ms to 10 ms.

**NOTE**

Although the user can modify the power-up and power-down sequence through the SEQx registers, those registers are reset to default values when the device enters SLEEP, OFF or RESET state. In practice this means that the power-up sequence is fixed and a other-than-default power-down sequence has to be written every time the device is powered up.

Custom power-up/down sequences can be checked out in ACTIVE mode (PWR\_EN pin high) by using the SEQUP and SEQDWN bits. To change the power-up default values, please contact the factory.

##### 9.3.1.1 Power-Up Sequencing

When the main power-up sequence is initiated, STROBE1 occurs and any rail assigned to this strobe will be enabled. After a delay time of DLY1 STROBE2 occurs and the rail assigned to this strobe is powered up. The sequence continues until all strobes have occurred and all DLYx times have been executed.

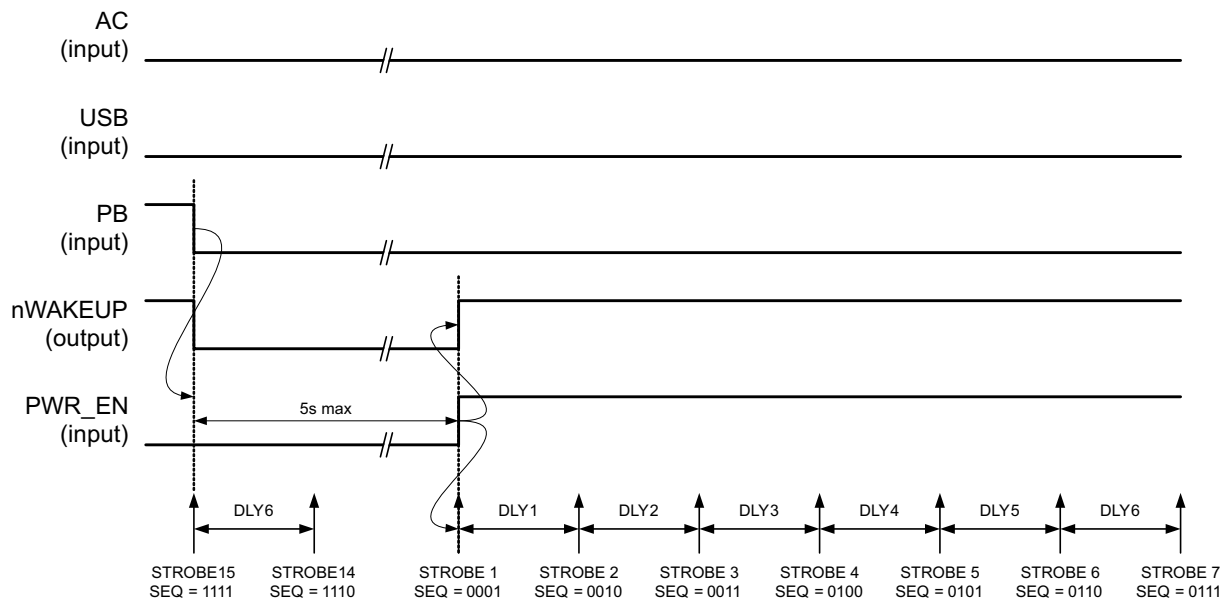

Power-Up Sequence is Defined by Strobes and Delay Times. In This Example, Push-Button Low is the Power-Up Event.

**Figure 3. Power-Up Sequence**

The default power-up sequence can be changed by writing to the SEQ1-6 registers. Strobes are assigned to rails by writing to the SEQ1-4 registers. A rail can be assigned to only one strobe but multiple rails can be assigned to the same strobe. Delays between strobes are defined in registers SEQ5 and SEQ6.

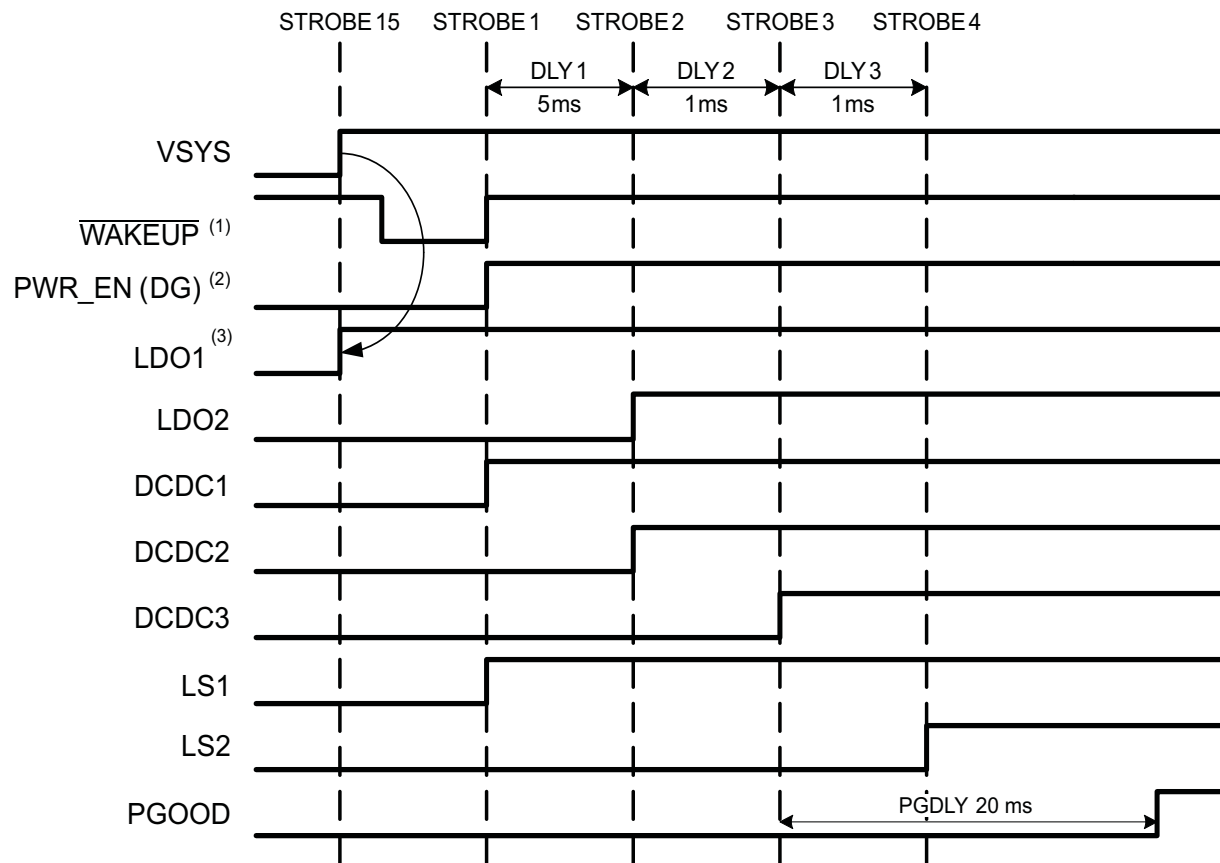
**Feature Description (continued)**

See [SLVU551](#) for the other TPS65217x family default power-up sequences.

**Figure 4. Default Power-Up Sequence for TPS65217A**

The power up sequence is executed if one of the following events occurs:

**From OFF State:**

- Push-button is pressed (falling edge on PB\_IN) OR
- USB voltage is asserted (rising edge on USB) OR
- AC adaptor is inserted (rising edge on AC) AND
- PWR\_EN pin is asserted (pulled high) AND
- Device is not in Under Voltage Lockout (UVLO) or Over Temperature Shutdown (OTS).

The PWR\_EN pin is level sensitive (opposed to edge sensitive) and it makes no difference if it is asserted before or after the above power-up events. However, it must be asserted within 5 seconds of the power-up event otherwise the power-down sequence will be triggered and the device enters either OFF state.

**From SLEEP State:**

- Push-button is pressed (falling edge on PB\_IN) OR
- USB voltage is asserted (rising edge on USB) OR
- AC adaptor is inserted (rising edge on AC) AND
- Device is not in Under Voltage Lockout (UVLO) or Over Temperature Shutdown (OTS) OR
- PWR\_EN pin is asserted (pulled high).

In SLEEP state the power-up sequence can be triggered by asserting the PWR\_EN pin only and the push-button press or USB/AC assertion are not required.

## Feature Description (continued)

### From ACTIVE State:

The sequencer can be triggered any time by setting the SEQUP bit of the SEQ6 register high. The SEQUP bit is automatically cleared after the sequencer is done.

Rails that are not assigned to a strobe (SEQ=0000b) are not affected by power-up and power-down sequencing and will remain in their current ON/OFF state regardless of the sequencer. Any rail can be enabled/disabled at any time by setting the corresponding enable bit in the ENABLE register with the only exception that the ENABLE register cannot be accessed while the sequencer is active. Enable bits always reflect the current enable state of the rail, i.e. the sequencer will set/reset the enable bits for the rails under its control. Also, whenever faults occur that shut-down the power-rails, the corresponding enable bits will be reset.

### 9.3.1.2 Power-Down Sequencing

By default, power-down sequencing follows the reverse power-up sequence. When the power-down sequence is triggered, STROBE7 occurs first and any rail assigned to STROBE7 will be shut down. After a delay time of DLY6, STROBE6 occurs and any rail assigned to it will be shut down. The sequence continues until all strobes have occurred and all DLYx times have been executed.

In some applications it is desired to shut down all rails simultaneously with no delay between rails. Set the INSTDWN bit in the SEQ6 register to bypass all delay times and shut-down all rails simultaneously when the power-down sequence is triggered.

A power-down sequence is executed if one of the following events occurs:

- The SEQDWN bit is set.
- The PWR\_EN pin is pulled low.
- The push-button is pressed for > 8 s.
- The nRESET pin is pulled low.
- A fault occurs in the IC (OTS, UVLO, PGOOD failure).
- The PWR\_EN pin is not asserted (pulled high) within 5 seconds of a power-up event and the OFF bit is set to 1.

When transitioning from ACTIVE to OFF state, any rail not controlled by the sequencer is shut down after the power-down sequencer has finished. When transitioning from ACTIVE to SLEEP state any rail not controlled by the power-down sequencer will maintain state. This allows keeping selected power rails up in SLEEP state.

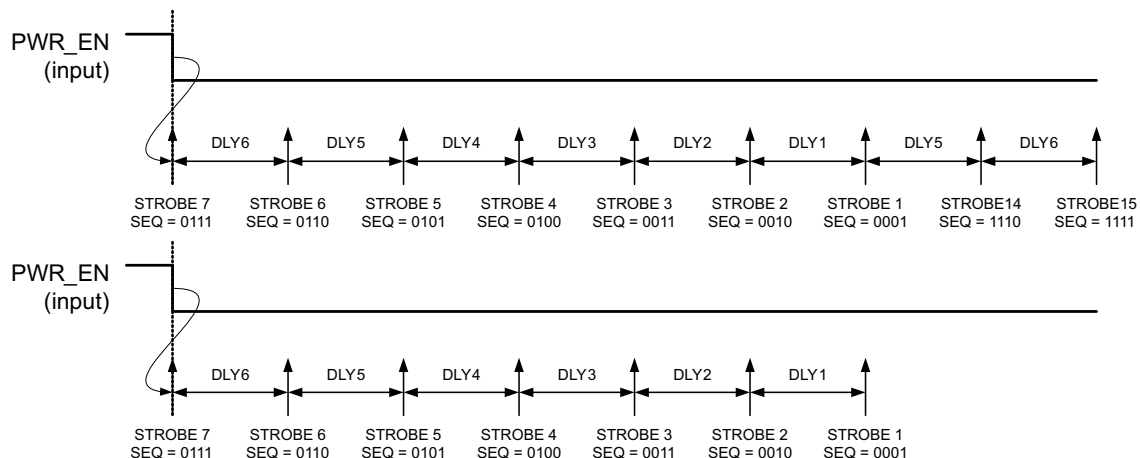

Power-Down Sequence Follows Reverse Power-Up Sequence. TOP: Power-Down sequence from ON state to OFF state (all rails are turned OFF). BOTTOM: Power-Down sequence from ON state to SLEEP state. STROBE14 and STROBE15 are omitted to allow LDO1/2 to remain ON.

**Figure 5. Power-Down Sequence**

## Feature Description (continued)

### 9.3.1.3 Special Strobes (STROBE 14 and 15)

STROBE 14 and STROBE 15 are not assigned to the main sequencer but used to control rails that are 'always-on', i.e. are powered up as soon as the device exits OFF state and remain ON in SLEEP state. STROBE 14/15 options are available only for LDO1 and LDO2 and not for any of the other rails.

STROBE 14 occurs as soon as the push-button is pressed or the USB or AC adaptor is connected to the device. After a delay time of DLY6 STROBE 15 occurs. LDO1 and LDO2 can be assigned to either strobe and therefore can be powered up in any order (contact factory for details - default settings must be factory programmed since all registers are reset in SLEEP mode).

When a power-down sequence is initiated, STROBE 15 and STROBE 14 will occur only if the OFF bit is set. Otherwise both strobes are omitted and LDO1 and LDO2 will maintain state.

### 9.3.2 Power Good

Power-good is a signal used to indicate if an output rail is in regulation or at fault. Internally, all power-good signals of the enabled rails are monitored at all times and if any of the signals goes low, a fault is declared. All PGOOD signals are internally deglitched. When a fault occurs, all output rails are powered down and the device enters OFF state.

The TPS65217 has two PGOOD outputs, one dedicated to LDO1 and 2 (LDO\_PGOOD), and one programmable output (PGOOD). The following rules apply to both outputs:

- The power-up default state for PGOOD/LDO\_PGOOD is low. When all rails are disabled, PGOOD and LDO\_PGOOD outputs are both low.
- Only enabled rails are monitored. Disabled rails are ignored.
- Power-good monitoring of a particular rail starts 5ms after the rail has been enabled. It is continuously monitored thereafter. This allows the rail to power-up.
- PGOOD and LDO\_PGOOD outputs are delayed by the PGDLY (20 ms default) after the sequencer is done.
- If an enabled rail goes down due to a fault (output shorted, OTS, UVLO), PGOOD and/or LDO\_PGOOD is declared low, and all rails are shut-down.
- If the user disables a rail (either manually or through sequencer), it has no effect on the PGOOD or LDO\_PGOOD pin.
- If the user disables all rails (either manually or through sequencer) PGOOD and/or LDO\_PGOOD will be pulled low.

#### 9.3.2.1 LDO1, LDO2 PGOOD (LDO\_PGOOD)

LDO\_PGOOD is a push-pull output which is driven to high-level whenever LDO1 and/or LDO2 are enabled and in regulation. It is pulled low when both LDOs are disabled or at least one is enabled but has encountered a fault. A typical fault is an output short or over-current condition. In normal operation LDO\_PGOOD is high in ACTIVE and SLEEP state and low in RESET or OFF state.

#### 9.3.2.2 Main PGOOD (PGOOD)

The main PGOOD pin has similar functionality to the LDO\_PGOOD pin except that it monitors DCDC1, DCDC2, DCDC3, and LS1/LDO3, LS2/LDO4 if they are configured as LDOs. If LS1/LDO3 and/or LS2/LDO4 are configured as load switches, their respective PGOOD status is ignored. In addition, the user can choose to also monitor LDO1 and LDO2 by setting the LDO1PGM and LDO2PGM bits in the DEFPG register low. By default, LDO1 and LDO2 PGOOD status does not affect the PGOOD pin (mask bits are set to 1 by default). In normal operation PGOOD is high in ACTIVE state but low in SLEEP, RESET or OFF state.

In SLEEP mode and WAIT PWR\_EN state, PGOOD pin is forced low. PGOOD is pulled high after entering ACTIVE mode, the power sequencer done, and the PGDLY expired. This function can be disabled by the factory.

#### 9.3.2.3 Load Switch PGOOD

If either LS1/LDO3 or LS2/LDO4 are configured as load switches their respective PGOOD signal is ignored by the system. An over-current or short condition will not affect the PGOOD pin or any of the power rails unless the power dissipation leads to thermal shut-down.

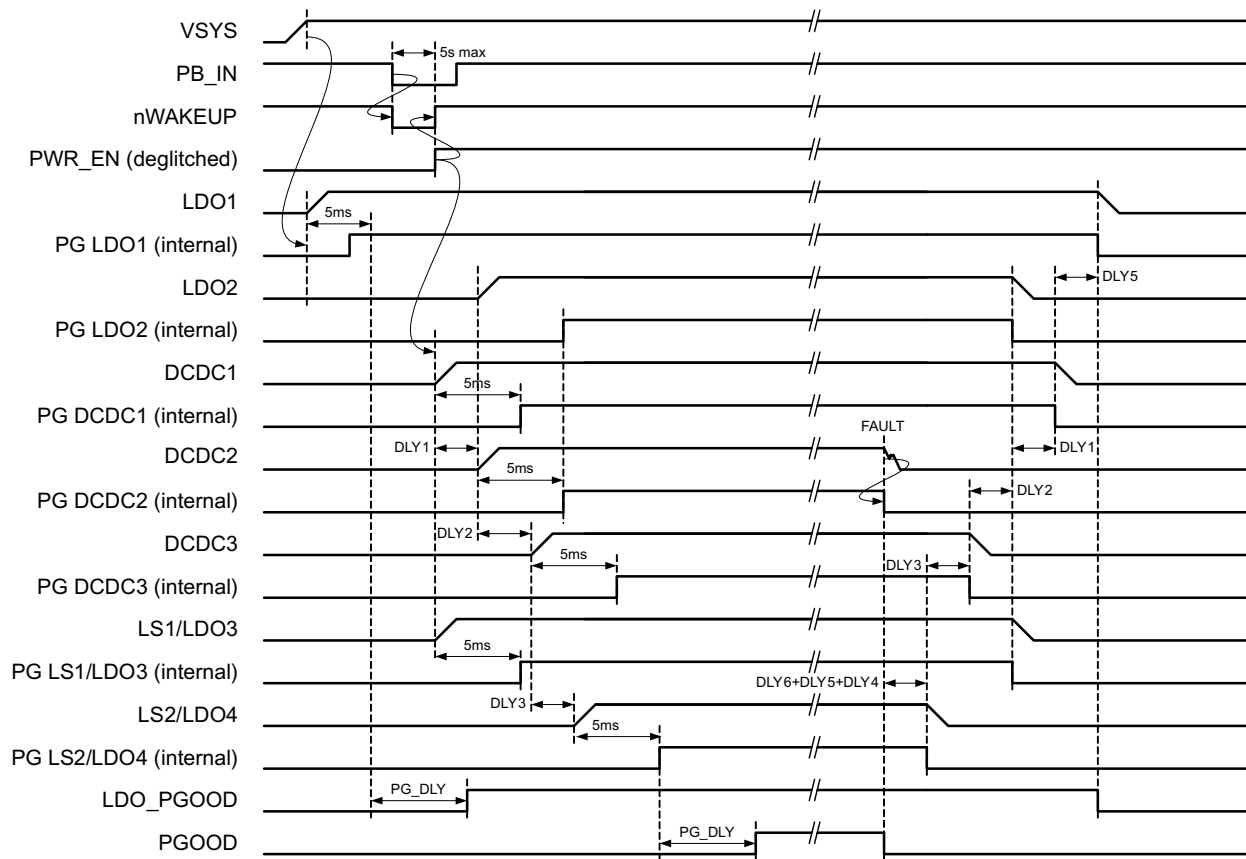
**Feature Description (continued)**

Also shown is the Power-Down sequence for the case of a short on DCDC2 output.

**Figure 6. Default Power-Up Sequence**

**9.3.3 Push Button Monitor (PB\_IN)**

The TPS65217 has an active-low push-button input which is typically connected to a momentary switch to ground. The PB\_IN input has a 50ms deglitch time and an internal pull-up resistor to an always-on supply. The push button monitor is used to:

- Power-up the device from OFF or SLEEP mode upon detecting a falling edge on PB\_IN.
- Power cycle the device when PB\_IN is held low for > 8 s.

Both functions are described in the Modes of Operation section. A change in push-button status (PB\_IN transitions high to low or low to high) is signaled to the host through the PBI interrupt bit in the INT register. The current status of the interrupt can be checked by reading the PB status bit in the STATUS register. A timing diagram for the push-button monitor is shown in .

Feature Description (continued)

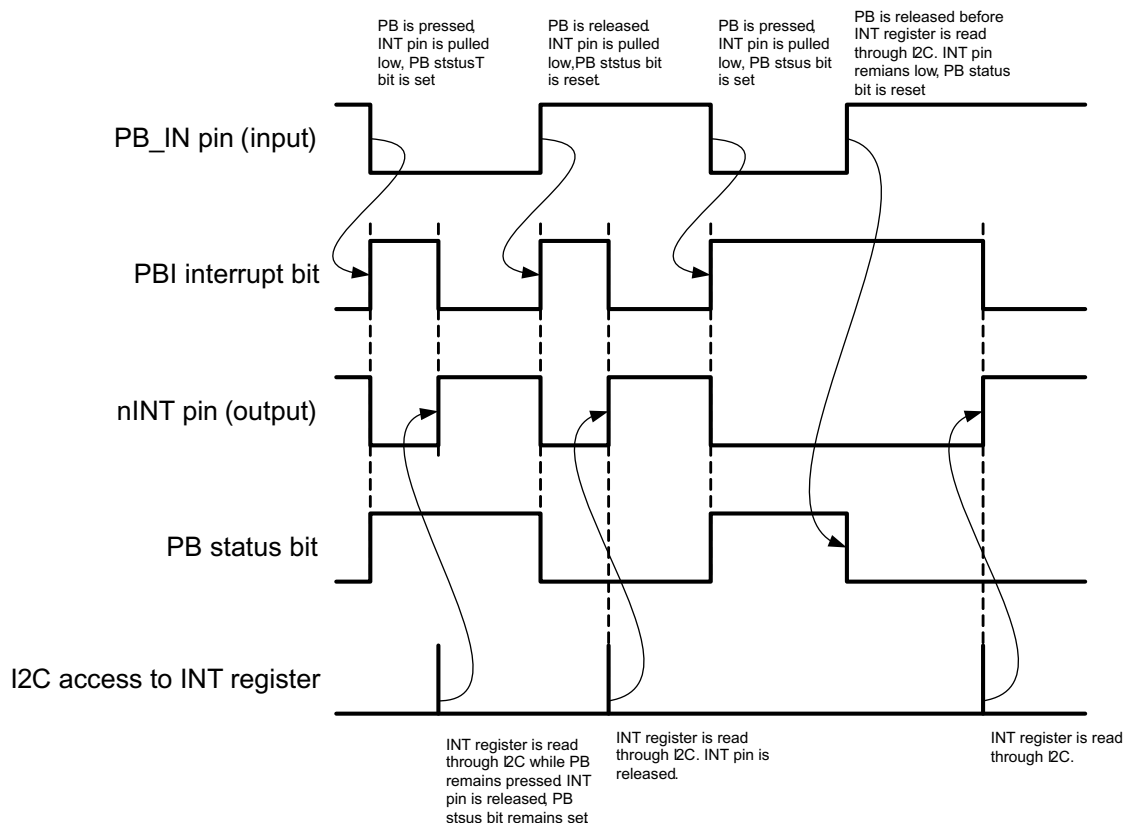

Figure 7. Timing Diagram of the Push-Button Monitor Circuit

9.3.4 nWAKEUP Pin (nWAKEUP)

The nWAKEUP pin is an open drain, active-low output that is used to signal a wakeup event to the system host. This pin is pulled low whenever the device is in OFF or SLEEP state and detects a wakeup event as described in the Modes of Operation section. The nWAKEUP pin is delayed 50 ms over the power-up event and will remain low for 50 ms after the PWR\_EN pin has been asserted. If the PWR\_EN pin is not asserted within 5 seconds of the power-up event, the device will shut down and enter OFF state. In ACTIVE mode the nWAKEUP pin is always high. The timing diagram for the nWAKEUP pin is shown in Figure 8.

9.3.5 Power Enable Pin (PWR\_EN)

The PWR\_EN pin is used to keep the unit in ACTIVE mode once it has detected a wakeup event as described in the Modes of Operation section. If the PWR\_EN pin is not asserted within 5 seconds of the nWAKEUP pin being pulled low, the device will shut down the power and enter either OFF or SLEEP mode, depending on the OFF bit in the STATUS register. The PWR\_EN pin is level sensitive, meaning that it may be pulled high before the wakeup event.

The PWR\_EN pin may also be used to toggle between ACTIVE and SLEEP mode. See SLEEP mode description for details.

## Feature Description (continued)

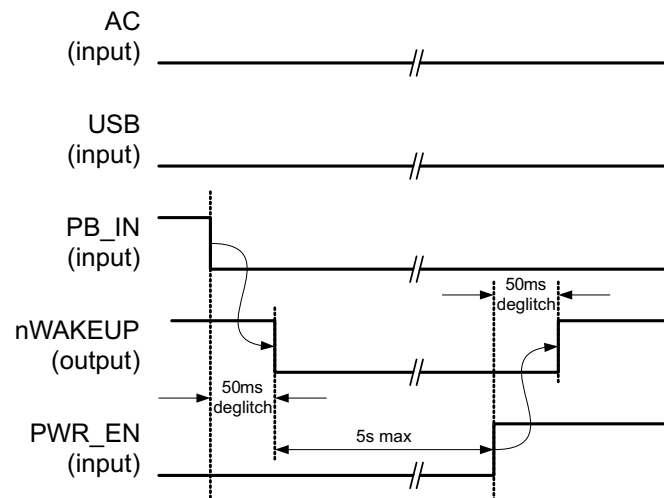

NOTE: If PWR\_EN pin is not asserted within 5s of the WAKEUP pin being pulled low, device will enter OFF or SLEEP mode.

In the example shown, the wakeup event is a falling edge on the PB\_IN.

**Figure 8. nWAKEUP Timing Diagram**

### 9.3.6 Reset Pin (nRESET)

When the nRESET pin is pulled low, all power rails, including LDO1 and LDO2 are powered down and default register settings are restored. The device will remain powered down as long as the nRESET pin is held low but for a minimum of 1 second. Once the nRESET pin is pulled high the device enters ACTIVE mode and the default power-up sequence will execute. See RESET section for more information.

### 9.3.7 Interrupt Pin (nINT)

The interrupt pin is used to signal any event or fault condition to the host processor. Whenever a fault or event occurs in the IC the corresponding interrupt bit is set in the INT register, and the open-drain output is pulled low. The nINT pin is released (returns to Hi-Z state) and fault bits are cleared when the INT register is read by the host. However, if a failure persists, the corresponding INT bit remains set and the nINT pin is pulled low again after a maximum of 32  $\mu$ s.

Interrupt events include pushbutton pressed/released, USB and AC voltage status change.

The MASK bits in the INT register are used to mask events from generating interrupts. The MASK settings affect the nINT pin only and have no impact on protection and monitor circuits themselves. Note that persisting event conditions such as ISINK enabled shutdown can cause the nINT pin to be pulled low for an extended period of time which can keep the host in a loop trying to resolve the interrupt. If this behavior is not desired, set the corresponding mask bit after receiving the interrupt and keep polling the INT register to see when the event condition has disappeared. Then unmask the interrupt bit again.

### 9.3.8 Analog Multiplexer

The TPS65217 provides an analog multiplexer that allow access to critical system voltages such as:

- Battery voltage (VBAT)
- System voltage (VSYS)
- Temperature sense voltage (VTS), and
- VICHARGE, a voltage proportional to the charging current.

In addition one external input is available to monitor an additional system voltage. VBAT and VSYS are divided down by a factor of 1:3 to be compatible with input voltage range of the ADC that resides on the system host side. The output of the MUX is buffered and can drive a maximum of 1-mA load current.



Feature Description (continued)

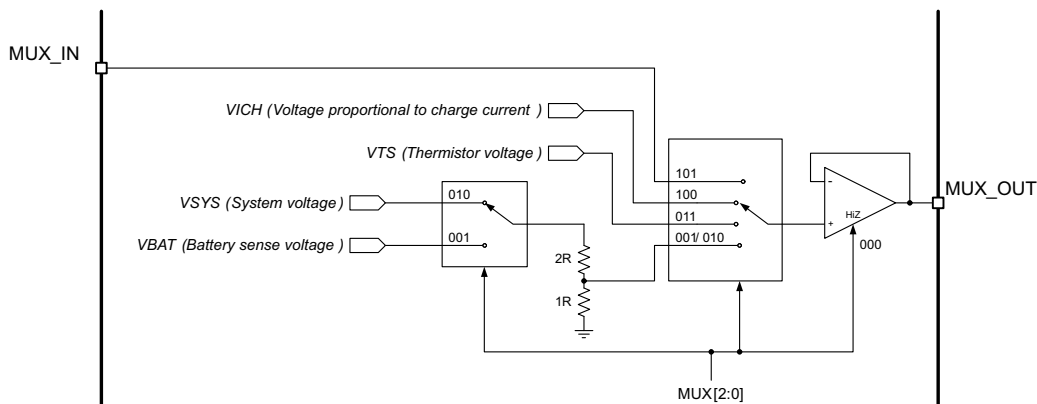

Figure 9. Analog Multiplexer

9.3.9 Battery Charger and Power Path

TPS65217 provides a linear charger for Li+ batteries and a triple system-power path targeted at space-limited portable applications. The power path allows simultaneous and independent charging of the battery and powering of the system. This feature enables the system to run with a defective or absent battery pack and allows instant system turn-on even with a totally discharged battery. The input power source for charging the battery and running the system can be either an AC adapter or a USB port. The power path prioritizes the AC input over the USB and both over battery input to reduce the number of charge and discharge cycles on the battery. Charging current is automatically reduced when system load increases and if the system load exceeds the maximum current of the USB or AC adapter supply, the battery will supplement, meaning that the battery will be discharged to supply the remaining current. A block diagram of the power path is shown in [Figure 10](#) and an example of the power path management function is shown in [Figure 11](#).

Feature Description (continued)

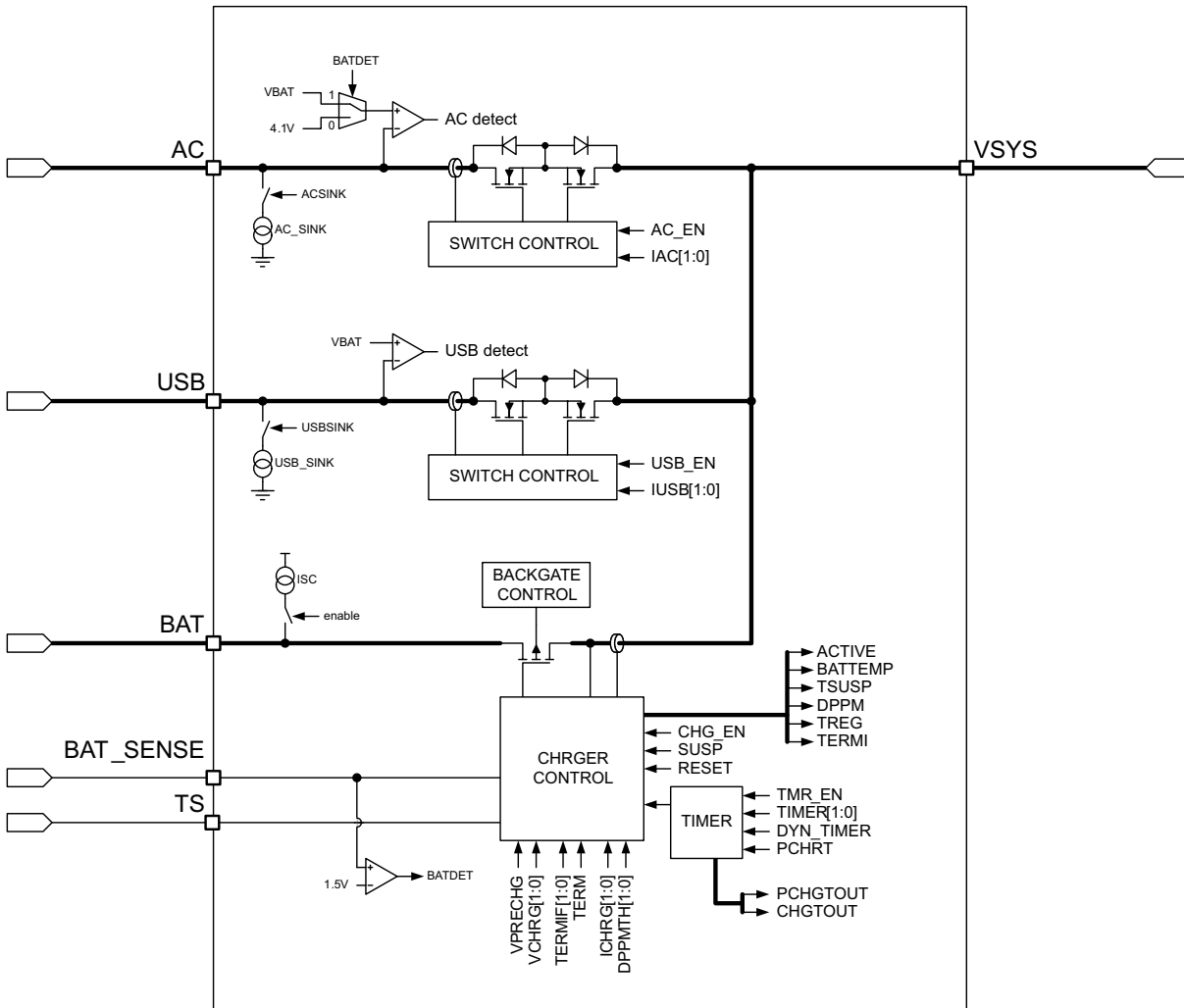
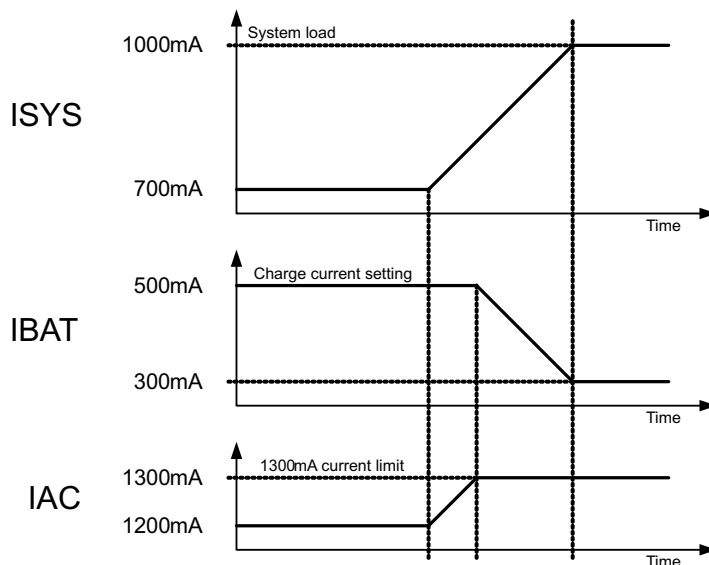

Figure 10. Block Diagram of the Power Path and Battery Charger

Feature Description (continued)



In this example, the AC input current limit is set to 1300 mA, battery charge current is 500 mA, and system load is 700 mA. As the system load increases to 1000 mA, battery charging current is reduced to 300 mA to maintain AC input current of 1300 mA.

Figure 11. Power Path Management

Detection thresholds for AC and USB inputs are a function of the battery voltage and three basic use-cases must be considered:

9.3.9.1 Shorted or Absent Battery ( $V_{BAT} < 1.5 V$ )

AC or USB inputs are valid and the chip powers up if  $V_{AC}$  or  $V_{USB}$  rises above 4.3 V. Once powered up, the input voltage can drop to the  $V_{UVLO} + V_{OFFSET}$  level (e.g. 3.3 V + 200 mV) before the chip powers down.

AC input is prioritized over USB input, i.e. if both inputs are valid, current is pulled from the AC input and not USB. If both, AC and USB supplies are available, the power-path switches to USB input if  $V_{AC}$  drops below 4.1 V (fixed threshold).

Note that the rise time of  $V_{AC}$  and  $V_{USB}$  must be less than 50 ms for the detection circuits to operate properly. If the rise time is longer than 50 ms, the IC may fail to power up.

The linear charger periodically applies a 10-mA current source to the BAT pin to check for the presence of a battery. This will cause the BAT terminal to float up to > 3 V which may interfere with AC removal detection and the ability to switch from AC to USB input. For this reason, it is not recommended to use both AC and USB inputs when the battery is absent.

9.3.9.2 Dead Battery ( $1.5 V < V_{BAT} < V_{UVLO}$ )

Functionality is the same as for the shorted battery case. The only difference is that once AC is selected as the input and the power-path does not switch back to USB as  $V_{AC}$  falls below 4.1 V.

9.3.9.3 Good Battery ( $V_{BAT} > V_{UVLO}$ )

AC and USB supplies are detected when the input is 190 mV above the battery voltage and are considered absent when the voltage difference to the battery is less than 125 mV. This feature ensures that AC and USB supplies are used whenever possible to save battery life. USB and AC inputs are both current limited and controlled through the PPATH register.

In case AC or USB is not present or blocked by the power path control logic (e.g. in OFF state), the battery voltage always supplies the system (SYS pin).

## Feature Description (continued)

### 9.3.9.4 AC and USB Input Discharge

AC and USB inputs have 90- $\mu$ A internal current sinks which are used to discharge the input pins to avoid false detection of an input source. The AC sink is enabled when USB is a valid supply and  $V_{AC}$  is below the detection threshold. Likewise, the USB sink is enabled when AC is a valid supply and  $V_{USB}$  is below the detection limit. Both current sinks can be forced OFF by setting the [ACSINK, USBSINK] bits to 11b. Both bits are located in register 0x01 (PPATH).

#### NOTE

[ACSINK, USBSINK] = 01b and 10b combinations are not recommended as these may lead to unexpected enabling and disabling of the current sinks.

### 9.3.10 Battery Charging

When the charger is enabled (CH\_EN bit set to 1) it first checks for a short-circuit on the BAT pin by sourcing a small current and monitoring the BAT voltage. If the voltage on the BAT pin rises above  $V_{BAT(SC)}$ , a battery is present and charging can begin. The battery is charged in three phases: pre-charge, constant current fast charge (current regulation) and a constant voltage charge (voltage regulation). In all charge phases, an internal control loop monitors the IC junction temperature and reduces the charge current if an internal temperature threshold is exceeded. Figure 12 shows a typical charging profile.

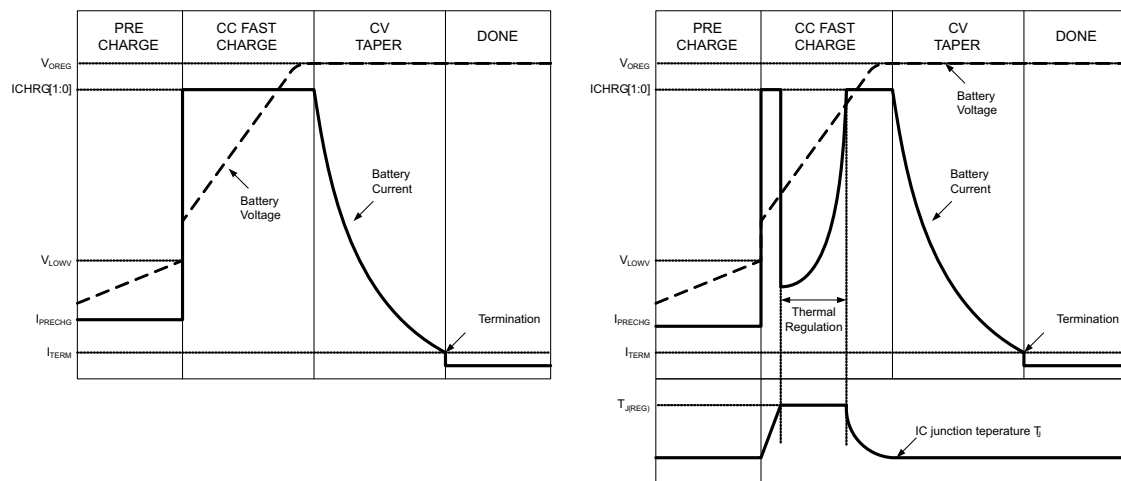

LEFT: Typical charge current profile with termination enabled.

RIGHT: Modified charging profile with thermal regulation loop active and termination enabled.

**Figure 12. Charging Profiles**

In the pre-charge phase, the battery is charged at a current of  $I_{PRECHG}$  which is typically 10% of the fast-charge current rate. The battery voltage starts rising. Once the battery voltage crosses the  $V_{LOWV}$  threshold, the battery is charged at a current of  $I_{CHG}$ . The battery voltage continues to rise. When the battery voltage reaches  $V_{OREG}$ , the battery is held at a constant value of  $V_{OREG}$ . The battery current now decreases as the battery approaches full charge. When the battery current reaches  $I_{TERM}$ , the  $TERMI$  flag in register  $CHGCONFIG0$  is set to 1. To avoid false termination when the DPM or thermal loop kicks in, termination is disabled when either loop is active.

The charge current cannot exceed the input current limit of the power path minus the load current on the SYS pin because the power-path manager will reduce the charge current to support the system load if the input current limit is exceeded. Whenever the nominal charge current is reduced by action of the power path manager, the DPM loop, or the thermal loop the safety timer is clocked with half the nominal frequency to extend the charging time by a factor of 2.

## Feature Description (continued)

### 9.3.11 Precharge

The pre-charge current is pre-set to a factor of 10% of the fast-charge current I<sub>CHRG</sub>[1:0] and cannot be changed by the user.

### 9.3.12 Charge Termination

When the charging current drops below the termination current threshold, the charger is turned off. The value of the termination current threshold can be set in register CHGCONFIG3 using bits TERMIF[1:0]. The termination current has a default setting of 7.5% of the I<sub>CHRG</sub>[1:0] setting.

Charge termination is enabled by default and can be disabled by setting the TERM bit or the CHGCONFIG1 register to 1. When termination is disabled, the device goes through the pre-charge, fast-charge and CV phases, then remains in the CV phase. The charger behaves like an LDO with an output voltage equal to V<sub>OREG</sub>, able to source current up to I<sub>CHG</sub> or I<sub>IN-MAX</sub>, whichever is less. Battery detection is not performed.

---

#### NOTE

Termination current threshold is not a tightly controlled parameter. Using the lowest setting (2.5% of nominal charge current) is not recommended because the minimum termination current can be very close to 0. Any leakage on the battery-side may cause the termination not to trigger and charging to time-out eventually.

---

### 9.3.13 Battery Detection and Recharge

Whenever the battery voltage falls below V<sub>RCH</sub>, I<sub>BAT(DET)</sub> is pulled from the battery for a duration t<sub>DET</sub> to determine if the battery has been removed. If the voltage on the BAT pin remains above V<sub>LOWV</sub>, it indicates that the battery is still connected. If the charger is enabled (CH\_EN = 1), a new battery charging cycle begins.

If the BAT pin voltage falls below V<sub>LOWV</sub> in the battery detection test, it indicates that the battery has been removed. The device then checks for battery insertion: it turns on the charging path and sources I<sub>PRECHG</sub> out of the BAT pin for duration t<sub>DET</sub>. If the voltage does not rise above V<sub>RCH</sub>, it indicates that a battery has been inserted, and a new charge cycle can begin. If, however, the voltage does rise above V<sub>RCH</sub>, it is possible that a fully charged battery has been inserted. To check for this, I<sub>BAT(DET)</sub> is pulled from the battery for t<sub>DET</sub> and if the voltage falls below V<sub>LOWV</sub>, no battery is present. The battery detection cycle continues until the device detects a battery or the charger is disabled.

When the battery is removed from the system the charger will also flag a BATTEMP error indicating that the TS input is not connected to a thermistor.

### 9.3.14 Safety Timer

The TPS65217 hosts internal safety timer for the pre-charge and fast-charge phases to prevent potential damage to either the battery or the system. The default fast-charge time can be changed in register CHGCONFIG1 and the precharge time in CHGCONFIG3. The timer functions can be disabled by resetting the TMR\_EN bit of the CHGCONFIG1 register to 0. Note that both timers are disabled when charge termination is disabled (TERM = 0).

#### 9.3.14.1 Dynamic Timer Function

Under some circumstances the charger current is reduced to react to changes in the system load or junction temperature. The two events that can reduce the charging current are:

- The system load current increases, and the DPM loop reduces the available charging current.
- The device has entered thermal regulation because the IC junction temperature has exceeded T<sub>J(REG)</sub>.

In each of these events, the timer is clocked with half frequency to extend the charger time by a factor of 2 and charger termination is disabled. Normal operation resumes after IC junction temperature has cooled off and/or the system load drops to a level where enough current is available to charge the battery at the desired charge rate. This feature is enabled by default and can be disabled by resetting the DYNTMR bit in the CHGCONFIG2 register to 0. A modified charge cycle with the thermal loop active is shown in [Figure 12](#).

## Feature Description (continued)

### 9.3.14.2 Timer Fault

A timer fault occurs if:

- If the battery voltage does not exceed  $V_{LOWV}$  in time  $t_{PRECHG}$  during pre-charging.
- If the battery current does not reach  $I_{TERM}$  in fast charge before the safetimer expires. Fast-charge time is measured from the beginning of the fast charge cycle.

The fault status is indicated by CHTOUT and PCHTOUT bits in CHGCONFIG0 register. Timeout faults are cleared and a new charge cycle is started when either USB or AC supplies are connected (rising edge of  $V_{USB}$  or  $V_{AC}$ ), the charger RESET bit is set to 1 in the CHGCONFIG1 register, or the battery voltage drops below the recharge threshold  $V_{RCH}$ .

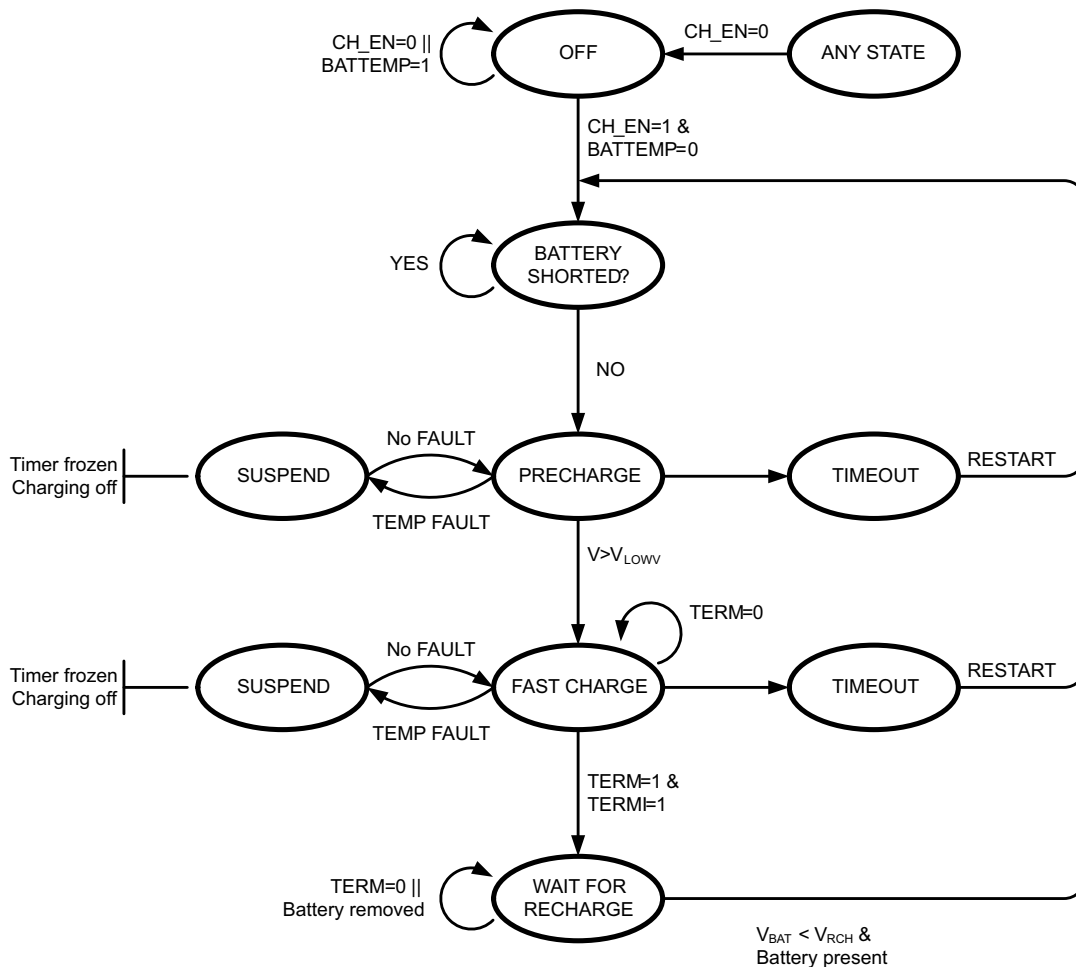

NOTES:  
 TEMP FAULT = Battery HOT || Battery cold || Thermal shutdown  
 RESTART =  $V_{USB}$  (↑) ||  $V_{AC}$  (↑) || Charger RESET bit (↑) ||  $V_{BAT} < V_{RCH}$

Figure 13. State Diagram of Battery Charger

### 9.3.15 Battery Pack Temperature Monitoring

The TS pin of the TPS65217 connects to the NTC resistor in the battery pack. During charging, if the resistance of the NTC indicates that the battery is operating outside the limits of safe operation, charging is suspended and the safety timer value is frozen. When the battery pack temperature returns to a safe value, charging resumes with the current timer setting.

**Feature Description (continued)**

By default, the device is setup to support a 10 kΩ the NTC with a B-value of 3480. The NTC is biased through a 7.35-kΩ internal resistor connected to the BYPASS rail (2.25 V) and requires an external 75-kΩ resistor parallel to the NTC to linearize the temperature response curve.

TPS65217 supports two different temperature ranges for charging, 0°C to 45°C and 0°C to 60°C which can be selected through the TRANGE bit in register CHCONFIG3.

**NOTE**

The device can be configured to support a 100-kΩ NTC (B = 3960) by setting the the NTC\_TYPE bit in register CHGCONFIG1 to 1. However it is not recommended to do so. In sleep mode, the charger continues charging the battery, but all register values are reset to default values. Therefore, the charger would get the wrong temperature information. If 100-kΩ NTC setting is required, please contact the factory.

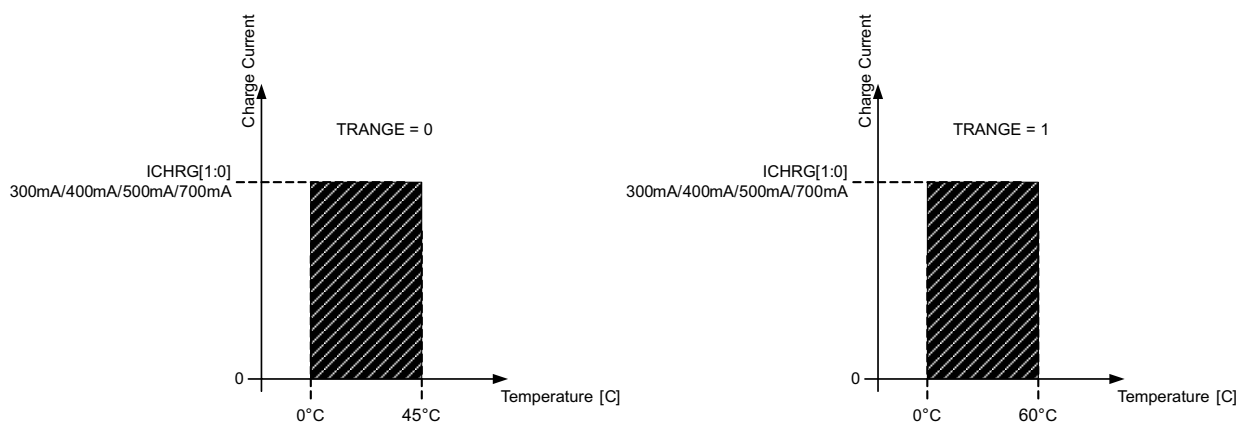

**Figure 14. Charge Current as a Function of Battery Temperature**

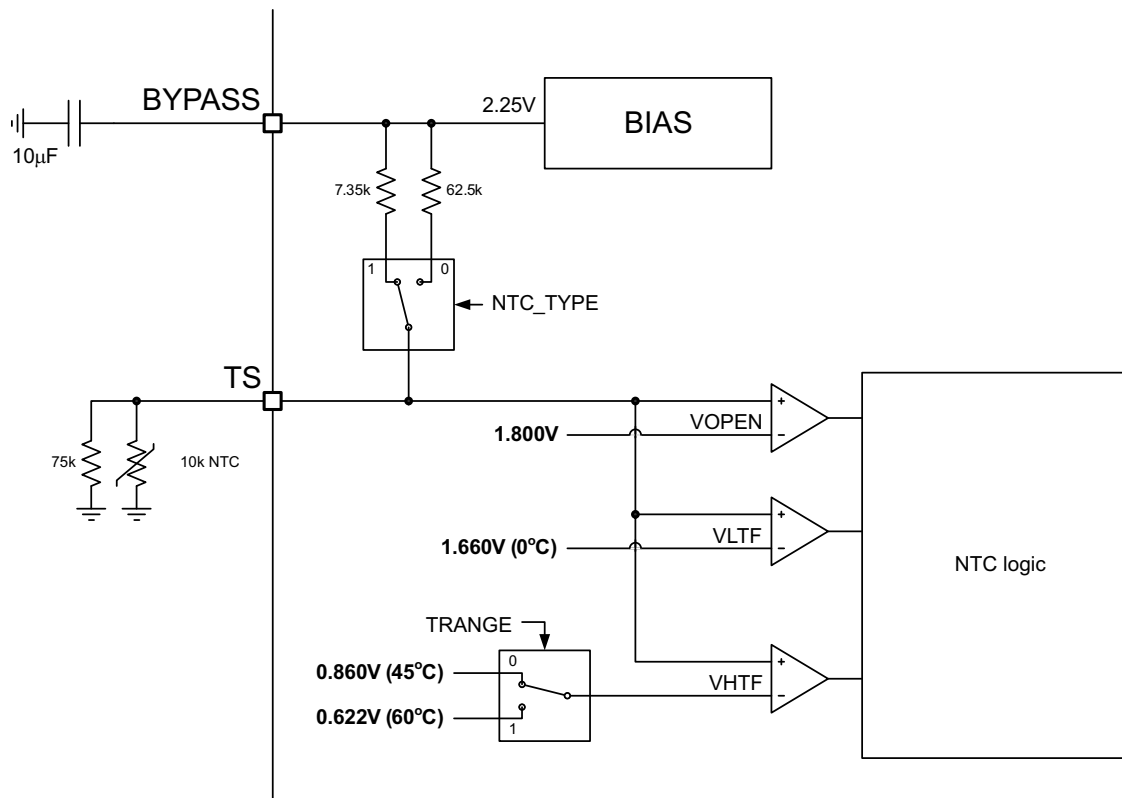
**Feature Description (continued)**

**Figure 15. NTC Bias Circuit**
**9.3.16 DC-DC Converters**
**9.3.16.1 Operation**

The TPS65217 step down converters typically operate with 2.25-MHz fixed frequency pulse width modulation (PWM) at moderate to heavy load currents. At light load currents the converter automatically enters Power Save Mode and operates in PFM (Pulse Frequency Modulation).

During PWM operation the converter use a unique fast response voltage mode controller scheme with input voltage feed-forward to achieve good line and load regulation allowing the use of small ceramic input and output capacitors. At the beginning of each clock cycle the high-side MOSFET is turned on. The current flows from the input capacitor via the high-side MOSFET through the inductor to the output capacitor and load. During this phase, the current ramps up until the PWM comparator trips and the control logic turns off the switch. The current limit comparator will also turn off the switch in case the current limit of the high-side MOSFET switch is exceeded. After a dead time preventing shoot through current, the low-side MOSFET rectifier is turned on and the inductor current ramps down. The current flows now from the inductor to the output capacitor and to the load. It returns back to the inductor through the low-side MOSFET rectifier.

The next cycle turns off the low-side MOSFET rectifier and turns on the on the high-side MOSFET.

The DC-DC converters operate synchronized to each other, with converter 1 as the master. A 120° phase shift between DCDC1/DCDC2 and DCDC2/DCDC3 decreases the combined input RMS current at the VIN\_DCDCx pins. Therefore smaller input capacitors can be used.

**9.3.16.2 Output Voltage Setting**

The output voltage of the DCDCs can be set in two different ways:

- As a fixed voltage converter where the voltage is defined in register DEFDCDCx.
- An external resistor network. Set the XADJx bit in register DEFDCDCx register and calculate the output



## Feature Description (continued)

voltage with the following formula:

$$V_{OUT} = V_{REF} \times \left(1 + \frac{R_1}{R_2}\right) \quad (1)$$

Where  $V_{REF}$  is the feedback voltage of 0.6 V. It is recommended to set the total resistance of  $R_1 + R_2$  to less than 1 M $\Omega$ . Shield the VDCDC1, VDCDC2, and VDCDC3 lines from switching nodes and inductor L1, L2, and L3 to prevent coupling of noise into the feedback pins.

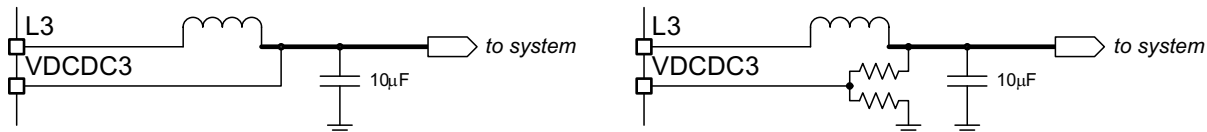

DCDC1, 2, and 3 Offer Two Methods to Adjust the Output Voltage.  
LEFT: Fixed Voltage Options Programmable Through I<sup>2</sup>C (XADJ3 = 0, default).  
RIGHT: Voltage is Set by External Feedback Resistor Network (XADJ3 = 1).

**Figure 16. Example for DCDC3**

### 9.3.16.3 Power Save Mode and Pulse Frequency Modulation (PFM)

By default, all three DC-DC converters enter Pulse Frequency Modulation (PFM) mode at light loads and fixed-frequency Pulse Width Modulation (PWM) mode at heavy loads. In some applications, it is desirable to force PWM operation even at light loads, which can be accomplished by setting the PFM\_ENx bits in the DEFSLEW registers to 0 (default setting is 1). In PFM mode, the converter skips switching cycles and operates with reduced frequency with a minimum quiescent current to maintain high efficiency. The converter will position the output voltage typically +1% above the nominal output voltage. This voltage positioning feature minimizes voltage drops caused by a sudden load step.

The transition from PWM to PFM mode occurs once the inductor current in the low-side MOSFET switch becomes 0.

During the power save mode, the output voltage is monitored with a PFM comparator. As the output voltage falls below the PFM comparator threshold of  $V_{OUT} - 1\%$ , the device starts a PFM current pulse. For this, the high-side MOSFET will turn on and the inductor current ramps up. Then, it is turned off and the low-side MOSFET switch turns on until the inductor current becomes 0 again.

The converter effectively delivers a current to the output capacitor and the load. If the load is below the delivered current, the output voltage will rise. If the output voltage is equal or higher than the PFM comparator threshold, the device stops switching and enters a sleep mode with typically 15- $\mu$ A current consumption. In case the output voltage is still below the PFM comparator threshold, further PFM current pulses will be generated until the PFM comparator threshold is reached. The converter starts switching again once the output voltage drops below the PFM comparator threshold.

With a single threshold comparator, the output voltage ripple during PFM mode operation can be kept very small. The ripple voltage depends on the PFM comparator delay, the size of the output capacitor, and the inductor value. Increasing output capacitor values and/or inductor values will minimize the output ripple.

The PFM mode is left and PWM mode entered in case the output current can no longer be supported in PFM mode or if the output voltage falls below a second threshold, called PFM comparator low threshold. This PFM comparator low threshold is set to -1% below nominal  $V_{OUT}$ , and enables a fast transition from power save mode to PWM mode during a load step.

The power save mode can be disabled through the I<sup>2</sup>C interface for each of the step-down converters independent from each other. If power save mode is disabled, the converter will then operate in fixed PWM mode.

## Feature Description (continued)

### 9.3.16.4 Dynamic Voltage Positioning

This feature reduces the voltage undershoots and overshoots at load steps from light to heavy load and vice versa. It is active in power save mode. It provides more headroom for both the voltage drop at a load step, and the voltage increase at a load throw-off. This improves load transient behavior. At light loads, in which the converter operates in PFM mode, the output voltage is regulated typically 1% higher than the nominal value. In case of a load transient from light load to heavy load, the output voltage drops until it reaches the PFM comparator low threshold set to  $-1\%$  below the nominal value and enters PWM mode. During a load throw off from heavy load to light load, the voltage overshoot is also minimized due to active regulation turning on the low-side MOSFET.

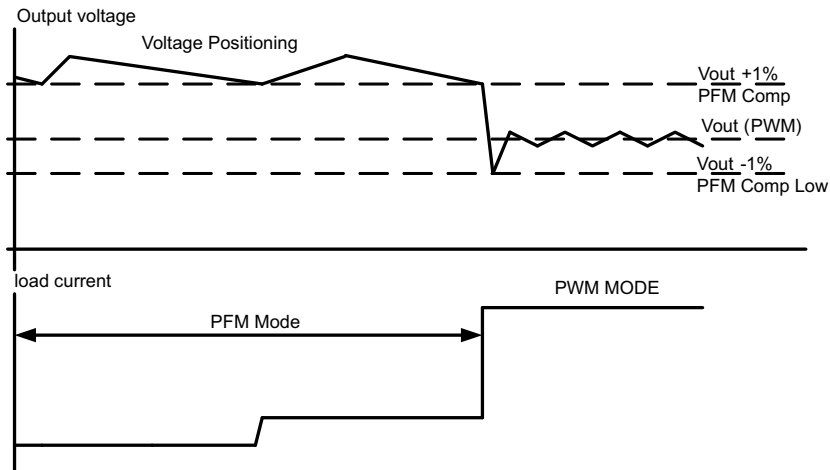

**Figure 17. Dynamic Voltage Positioning in Power Save Mode**

### 9.3.16.5 100% Duty Cycle Low Dropout Operation

The device starts to enter 100% duty cycle mode once the input voltage comes close the nominal output voltage. In order to maintain the output voltage, the high-side MOSFET is turned on 100% for one or more cycles. As  $V_{IN}$  decreases further, the high-side MOSFET is turned on completely. In this case the converter offers a low input-to-output voltage difference. This is particularly useful in battery-powered applications to achieve longest operation time by taking full advantage of the whole battery voltage range.

The minimum input voltage to maintain regulation depends on the load current and output voltage, and can be calculated as:

$$V_{IN,MIN} = V_{OUT,MAX} + I_{OUT,MAX} \cdot (R_{DS(on),MAX} + R_L)$$

where

- $I_{OUT,MAX}$  = Maximum output current plus inductor ripple current
  - $R_{DS(on),MAX}$  = Maximum upper MOSFET switch  $R_{DS(on)}$
  - $R_L$  = DC resistance of the inductor
  - $V_{OUT,MAX}$  = Nominal output voltage plus maximum output voltage tolerance
- (2)

### 9.3.16.6 Short-Circuit Protection

High-side and low-side MOSFET switches are short-circuit protected. Once the high-side MOSFET switch reaches its current limit, it is turned off and the low-side MOSFET switch is turned ON. The high-side MOSFET switch can only turn on again, once the current in the low-side MOSFET switch decreases below its current limit.

## Feature Description (continued)

### 9.3.16.7 Soft Start

The three step-down converters in TPS65217 have an internal soft start circuit that controls the ramp up of the output voltage. The output voltage ramps up from 5% to 95% of its nominal value within 750  $\mu$ s. This limits the inrush current in the converter during start up and prevents possible input voltage drops when a battery or high impedance power source is used. The soft start circuit is enabled after the start up time  $t_{Start}$  has expired.

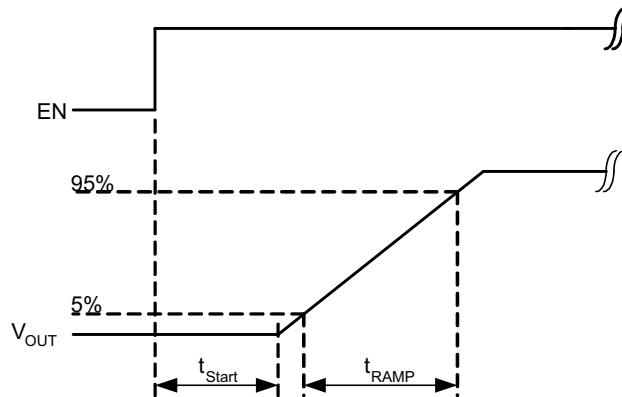

**Figure 18. Output of the DC-DC Converters is Ramped Up Within 750  $\mu$ s**

### 9.3.17 Standby LDOS (LDO1, LDO2)

LDO1 and LDO2 support up to 100 mA each, are internally current limited, and have a maximum drop-out voltage of 200 mV at rated output current. In SLEEP mode, however, output current is limited to 1 mA each. When disabled, both outputs are discharged to ground through a 430- $\Omega$  resistor.

LDO1 supports an output voltage range of 1.0 V - 1.8 V, which is controlled through the DEFLDO1 register. LDO2 supports an output voltage range from 0.9 V - 1.5 V, and is controlled through the DEFLDO2 register. By default, LDO1 is enabled immediately after a power-up event as described in the Modes of Operation section and remains ON in SLEEP mode to support system standby. Each LDO has low standby-current of < 15  $\mu$ A typical.

LDO2 can be configured to track the output voltage of DCDC3 (core voltage). When the TRACK bit is set in the DEFLDO2 register, the output is determined by the DCDC3[5:0] bits of the DEFDCDC3 register and the LDO2[5:0] bits of the DEFLDO2 register are ignored.

LDO1 and LDO2 can be controlled through STROBE 1-6, special STROBES 14 and 15, or through the corresponding enable bits in the ENABLE register. By default, LDO1 are controlled through STROBE15, which keeps it alive in SLEEP mode. The STROBE assignments can be changed by the user while in ACTIVE mode, but be aware that all register settings are reset to default values in SLEEP or OFF mode. This can cause the LDO to power up automatically when leaving SLEEP mode, even though they have been disabled in SLEEP mode previously by assigning them to a different strobe or resetting the corresponding enable bit. If this is not desired, new default values must be programmed into non-volatile memory by the factory. Contact TI for details.

### 9.3.18 Load Switches/LDOS (LS1/LDO3, LS2/LDO4)

TPS65217 provides two general-purpose load switches that can also be configured as LDOs. As LDOs they support up to 200 mA each, are internally current limited, and have a maximum drop-out voltage of 200 mV at rated output current. LDO3 and LDO4 of the TPS65217C and TPS65217D devices support up to 400-mA of current. In either mode ON/OFF state can be controlled either through the sequencer or the LS1\_EN and LS2\_EN bits of the ENABLE register. When disabled, both outputs are discharged to ground through a 375- $\Omega$  resistor.

As load switches LS1 and LS2 have a max impedance of 650 m $\Omega$ . Different from LDO operation, load switches can remain in current limit indefinitely without affecting the internal power-good signal or affecting the other rails. Please note, however, that excessive power dissipation in the switches may cause thermal shutdown of the IC.

### Feature Description (continued)

Load switch and LDO mode are controlled by LS1LDO3 and LS2LDO4 bits of the DEFLS1 and DEFLS2 registers.

#### 9.3.19 White LED Driver

TPS65217 contains a boost converter and two current sinks capable of driving up to 2 x 10 LEDs at 25 mA or a single string at 50 mA of current. The current per current sink is approximated by the following equation:

$$I_{LED} = 1048 \times \frac{1.24V}{R_{SET}} \tag{3}$$

Two different current levels can be programmed using two external  $R_{SET}$  resistors. Only one current setting is active at any given time and both current sinks are always regulated to the same current. The active current setting is selected through the ISEL bit of the WLEDCTRL1 register.

Brightness dimming is supported by an internal PWM signal and I<sup>2</sup>C control. Both current sources are controlled together and cannot operate independently. By default, the PWM frequency is set to 200 Hz, but can be changed to 100 Hz, 500 Hz, and 1000 Hz. The PWM duty cycle can be adjusted from 1% (default) to 100% in 1% steps through the WLEDCTRL2 register.

When the ISINK\_EN bit of WLEDCTRL1 register is set to 1, both current sinks are enabled and the boost output voltage at the FB\_WLED pin is regulated to support the same  $I_{SINK}$  current through each current sink. The boost output voltage, however, is internally limited to 39 V.

If only a single WLED string is required, short ISINK1 and ISINK2 pins together and connect them to the Cathode of the diode string. Note that the LED current in this case is 2 x  $I_{SINK}$ . See Table 32 and Table 33 for recommended inductors and output capacitors for WLED boost converters.

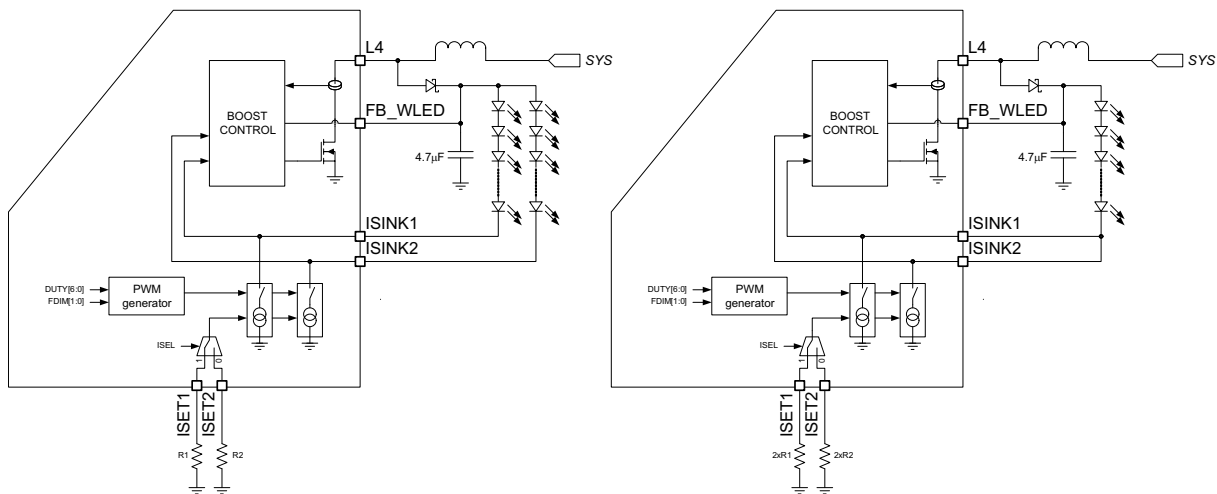

LEFT: Dual string operation.

RIGHT: Single string operation (same LED current as dual string). Note that for single string operation, both ISINK pins are shorted together and RSET values are doubled.

**Figure 19. Block Diagram of WLED Driver**

## 9.4 Device Functional Modes

### 9.4.1 Modes of Operation

- OFF** In OFF mode, the PMIC is completely shut down with the exception of a few circuits to monitor the AC, USB, and push-button input. All power rails are turned off and the registers are reset to their default values. The I<sup>2</sup>C communication interface is turned off. This is the lowest-power mode of operation. To exit OFF mode one of the following wake-up events has to occur:
- The push button input is pulled low.
  - The USB supply is connected (positive edge).
  - The AC adapter is connected (positive edge).
- To enter OFF state, set the OFF bit in the STATUS register to '1', and then pull the PWR\_EN pin low. Please note that in normal operation, OFF state can only be entered from ACTIVE state. Whenever a fault occurs during operation such as thermal shutdown, power-good fail, undervoltage lockout, or PWR\_EN pin timeout, all power rails are shut down and the device goes to OFF state. The device will remain in OFF state until the fault has been removed and a new power-up event has occurred.
- ACTIVE** This is the typical mode of operation when the system is up and running. All DC-DC converters, LDOs, load switches, WLED driver, and battery charger are operational and can be controlled through the I<sup>2</sup>C interface.
- After a wake-up event, the PMIC enables all rails not controlled by the sequencer and pulls the nWAKEUP pin low to signal the event to the host processor. The device will enter ACTIVE state only if the host asserts the PWR\_EN pin within 5 seconds after the wake-up event. Otherwise, it will enter OFF state. In ACTIVE state, the sequencer is triggered to bring up the remaining power rails. The nWAKEUP pin returns to Hi-Z mode after PWR\_EN pin has been asserted. A timing diagram is shown in [Figure 3](#). ACTIVE state can also be entered from SLEEP state directly by pulling the PWR\_EN pin high. See SLEEP state description for details.
- To exit ACTIVE mode the PWR\_EN pin needs to be pulled low.
- SLEEP** SLEEP state is a low-power mode of operation intended to support system standby. Typically, all power rails are turned off with the exception of LDO1 and the registers are reset to their default values. LDO1 remains operational but can support only limited amount of current (1 mA typical).
- To enter SLEEP state, set the OFF bit in the STATUS register to '0' (default), and then pull the PWR\_EN pin low. All power rails controlled by the power-down sequencer will be shut down and after 1s the device enters SLEEP state. If LDO1 was enabled in ACTIVE state, it will remain enabled in SLEEP state. All rails not controlled by the power-down sequencer will also maintain state. The battery charger will remain active for as long as either USB or AC supply is connected to the device. Please note that all register values are reset as the device enters in SLEEP state, including charger parameters.
- The device enters ACTIVE state after it detects a wake-up event as described in the sections above. In addition, the device transitions from SLEEP to ACTIVE state when the PWR\_EN pin is pulled high. This allows the system host to switch the PMIC between ACTIVE to SLEEP state by control of the PWR\_EN pin only.
- RESET** The TPS65217 can be reset by either pulling the nRESET pin low or holding the PB\_IN pin low for more than 8 seconds. All rails will be shut down by the sequencer and all register values are reset to their default values. Rails not controlled by the sequencer are shut down immediately. The device remains in this state for as long as the reset pin is held low and the nRESET pin must be high to exit RESET state. However, the device will remain in RESET state for a minimum of 1 second before it returns to ACTIVE state. As described in the ACTIVE section, the PWR\_EN pin must be asserted within 5 seconds of nWAKEUP-pin-low to enter ACTIVE state. Please note that the RESET function power-cycles the device and only shuts down the output rails temporarily. Resetting the device does not lead to OFF state.
- If the PB\_IN pin is kept low for an extended amount of time, the device will continue to cycle between ACTIVE and RESET state, entering RESET every 8 seconds.

Device Functional Modes (continued)

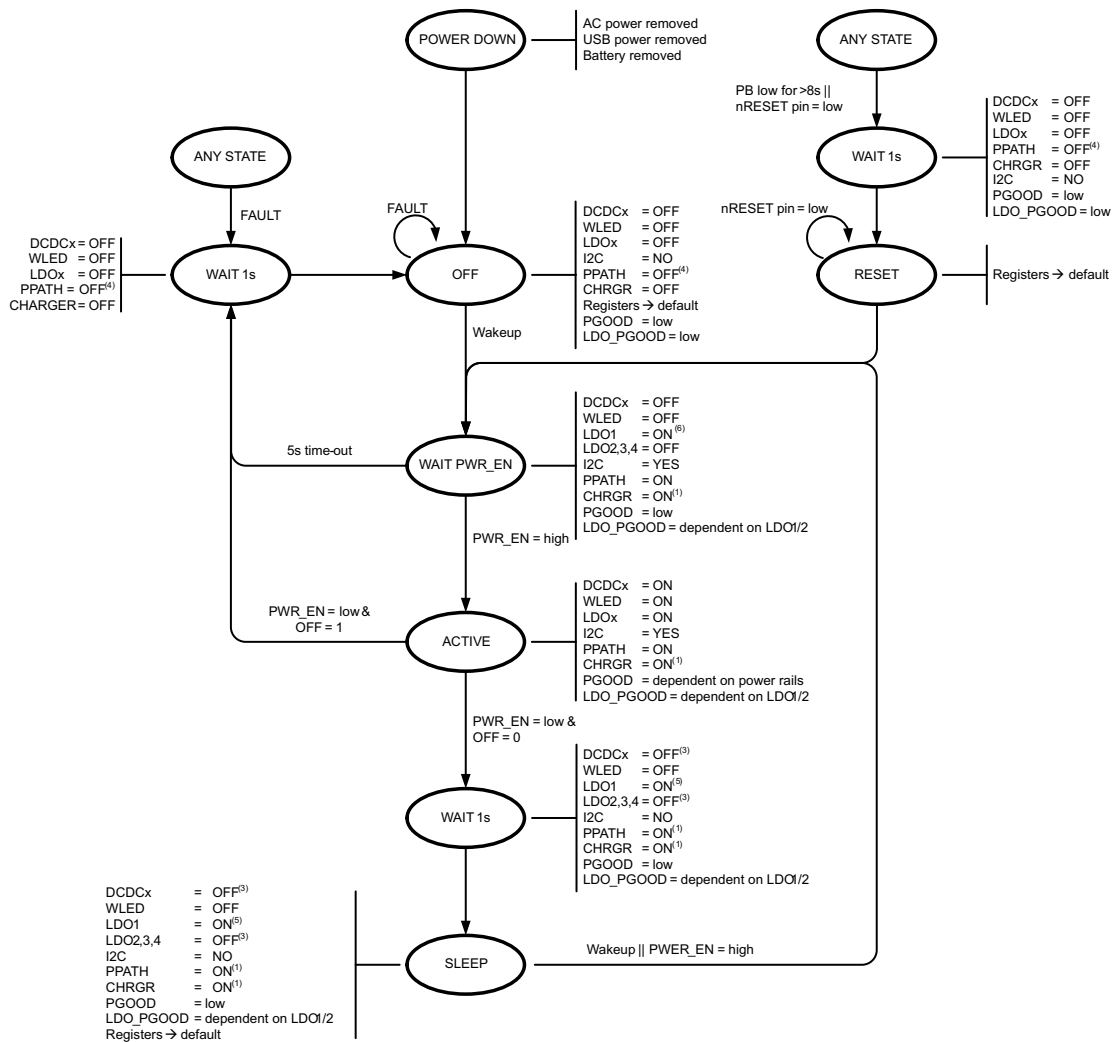

**NOTES:**  
 Wakeup =  $V_{USB}(\uparrow) \parallel V_{AC}(\uparrow) \parallel PB(\downarrow) \parallel$  Returning from RESET state| SEQUP bit= 1  
 FAULT =  $LVL0 \parallel OTS \parallel PGOOD \text{ low} \parallel PWR\_EN \text{ pin not asserted within } 5s \text{ of Wakeup event}$   
 If no battery is present OVP on AC input also leads to OFF mode. With battery present device switches automatically from AC to BAT if AC is >6.5V and back to AC when voltage recovers to >6.5V.  
 Device will remain in RESET state for at least 1s.  
 Sequencer is triggered when entering ACTIVE state

(1) Only if USB or AC supply is present  
 (2) All rails not controlled by the sequencer maintain state when entering SLEEP mode, i.e. they will not be powered down when entering SLEEP mode  
 (3) Battery voltage always supplies the system (SYS pin)  
 (4) LDO1/2 are not powered down when entering SLEEP mode if assigned to STROBE 14/15 or not under sequencer control. In SLEEP mode, LDO1 and 2 can source 1 mA only. By default LDO1 is assigned to STROBE15 and LDO2 to STROBE2.  
 (5) LDO1 and/or LDO2 are powered up if assigned to STROBE 14/15. By default LDO1 is assigned to STROBE15 and LDO2 to STROBE2.

Figure 20. Global State Diagram

## 9.5 Programming

### 9.5.1 I<sup>2</sup>C Bus Operation

The TPS65217 hosts a slave I<sup>2</sup>C interface that supports data rates up to 400 kbit/s and auto-increment addressing and is compliant to I<sup>2</sup>C standard 3.0.

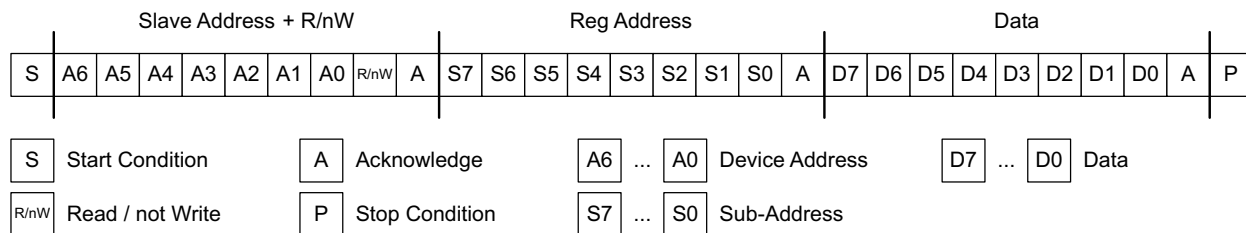
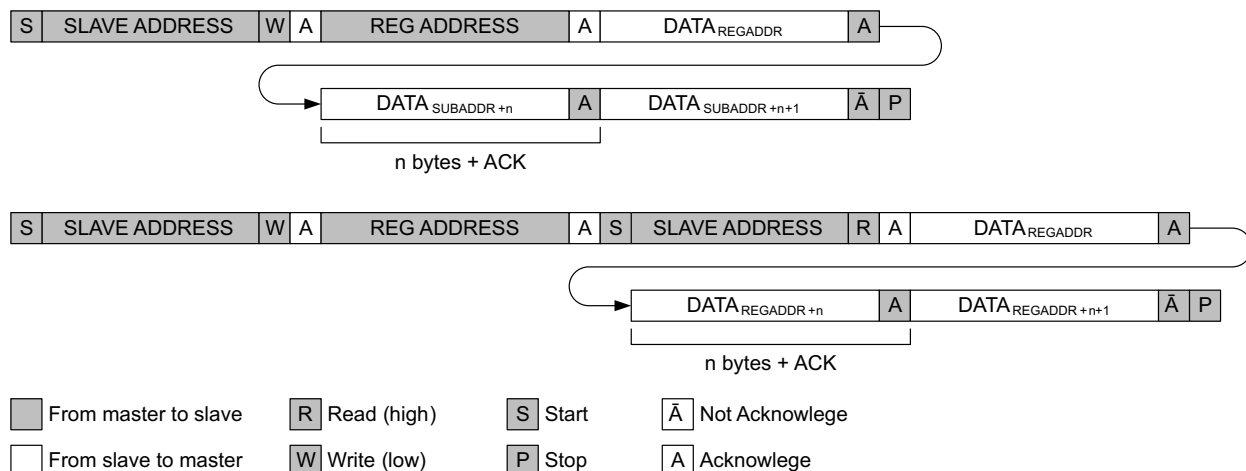

Figure 21. Sub-Address in I<sup>2</sup>C Transmission

The I<sup>2</sup>C Bus is a communications link between a controller and a series of slave terminals. The link is established using a two-wired bus consisting of a serial clock signal (SCL) and a serial data signal (SDA). The serial clock is sourced from the controller in all cases where the serial data line is bi-directional for data communication between the controller and the slave terminals. Each device has an open Drain output to transmit data on the serial data line. An external pull-up resistor must be placed on the serial data line to pull the drain output high during data transmission.

Data transmission is initiated with a start bit from the controller as shown in Figure 23. The start condition is recognized when the SDA line transitions from high to low during the high portion of the SCL signal. Upon reception of a start bit, the device will receive serial data on the SDA input and check for valid address and control information. If the appropriate group and address bits are set for the device, then the device will issue an acknowledge pulse and prepare the receive of sub-address data. Sub-address data is decoded and responded to as per Register Maps. Data transmission is completed by either the reception of a stop condition or the reception of the data word sent to the device. A stop condition is recognized as a low to high transition of the SDA input during the high portion of the SCL signal. All other transitions of the SDA line must occur during the low portion of the SCL signal. An acknowledge is issued after the reception of valid address, sub-address and data words. The I<sup>2</sup>C interfaces will auto-sequence through register addresses, so that multiple data words can be sent for a given I<sup>2</sup>C transmission. Reference Figure 22 and Figure 23 for detail.



TOP: Master writes data to slave. BOTTOM: Master reads data from slave.

Figure 22. I<sup>2</sup>C Data Protocol



## Programming (continued)

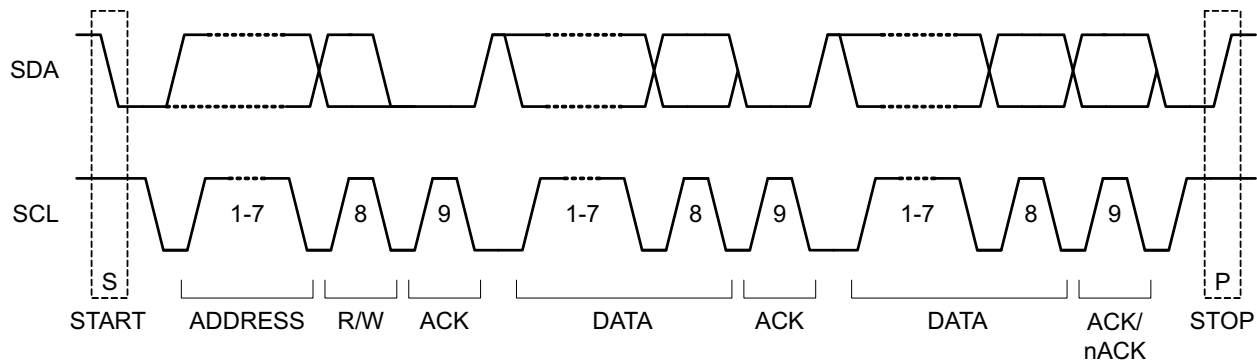

**Figure 23. I<sup>2</sup>C Start/Stop/Acknowledge Protocol**

### 9.5.2 Password Protection

Registers 0x0B through 0x1F with exception of the password register are protected against accidental write by a 8-bit password. The password needs to be written prior to writing to a protected register and is automatically reset to 0x00h after the following I<sup>2</sup>C transaction, regardless of the register that was accessed and regardless of the transaction type (read or write). The password is required for write access only and is not required for read access.

#### 9.5.2.1 Level1 Protection

To write to a Level1 protected register:

1. Write the address of the destination register, XORed with the protection password (0x7Dh) to the PASSWORD register.
2. Write data to the password protected register.
3. Only if the content of the PASSWORD register XORed with the address send in step 2 matches 0x7Dh, the data will be transferred to the protected register. Otherwise, the transaction will be ignored. In any case, the PASSWORD register is reset to 0x00 after the transaction.

The cycle needs to be repeated for any other register that is Level1 write protected.

#### 9.5.2.2 Level2 Protection

To write to a Level2 protected register:

1. Write the address of the destination register, XORed with the protection password (0x7Dh) to the PASSWORD register.
2. Write to the password protected register. The register value will not change at this point but the data will be temporarily stored if the content of the PASSWORD register XORed with the address send in step 2 matches 0x7Dh. In any case, the PASSWORD register is reset to 0x00 after the transaction.
3. Write the address of the destination register, XORed with the protection password (0x7Dh) to the PASSWORD register.
4. Write the same data as in step 2 to the password protected register. Again, the content of the PASSWORD register XORed with the address send in step 4 must match 0x7Dh for the data to be valid.
5. The register will be updated only if both data transfers 2, and 4 were valid, and the transferred data matched.

Note that no other I<sup>2</sup>C transaction is allowed between step 2 and 4 and the register will not be updated if any other transaction occurs in-between. The cycle needs to be repeated for any other register that is Level2 write protected.

### 9.5.3 Reset to Default Values

All registers are reset to default values when one or more of the following conditions occur:

- The device transitions from ACTIVE state to SLEEP or OFF state.



## Programming (continued)

- VBAT or VUSB is applied from power-less state (Power-On-Reset).
- Push-button input is pulled high for > 8 s.
- nRESET pin is pulled low.
- A fault occurs.

## 9.6 Register Maps

### 9.6.1 Register Address Map

**Figure 24. Register Address Map**

REGISTER	ADDRESS (HEX)	NAME	PROTECTION	DEFAULT VALUE	DESCRIPTION
0	0	CHIPID	None	N/A	Chip ID
1	1	PPATH	None	N/A	Power path control
2	2	INT	None	N/A	Interrupt flags and masks
3	3	CHGCONFIG0	None	N/A	Charger control register 0
4	4	CHGCONFIG1	None	N/A	Charger control register 1
5	5	CHGCONFIG2	None	N/A	Charger control register 2
6	6	CHGCONFIG3	None	N/A	Charger control register 3
7	7	WLEDCTRL1	None	N/A	WLED control register
8	8	WLEDCTRL2	None	N/A	WLED PWM duty cycle
9	9	MUXCTRL	None	N/A	Analog Multiplexer control register
10	0A	STATUS	None	N/A	Status register
11	0B	PASSWORD	None	N/A	Write password
12	0C	PGOOD	None	N/A	Power good (PG) flags
13	0D	DEFPG	Level1	N/A	Power good (PG) delay
14	0E	DEFDCDC1	Level2	N/A	DCDC1 voltage adjustment
15	0F	DEFDCDC2	Level2	N/A	DCDC2 voltage adjustment
16	10	DEFDCDC3	Level2	N/A	DCDC3 voltage adjustment
17	11	DEFSLEW	Level2	N/A	Slew control DCDC1-3/PFM mode enable
18	12	DEFLDO1	Level2	N/A	LDO1 voltage adjustment
19	13	DEFLDO2	Level2	N/A	LDO2 voltage adjustment
20	14	DEFLS1	Level2	N/A	LS1/LDO3 voltage adjustment
21	15	DEFLS2	Level2	N/A	LS2/LDO4 voltage adjustment
22	16	ENABLE	Level1	N/A	Enable register
23	18	DEFUVLO	Level1	N/A	UVLO control register
24	19	SEQ1	Level1	N/A	Power-up STROBE definition
25	1A	SEQ2	Level1	N/A	Power-up STROBE definition
26	1B	SEQ3	Level1	N/A	Power-up STROBE definition
27	1C	SEQ4	Level1	N/A	Power-up STROBE definition
28	1D	SEQ5	Level1	N/A	Power-up delay times
29	1E	SEQ6	Level1	N/A	Power-up delay times

LEGEND: R/W = Read/Write; R = Read only; -n = value after reset

**9.6.2 Chip ID Register (CHIPID)**
**Figure 25. Chip ID Register (CHIPID)  
Address – 0x00h**

DATA BIT		D7	D6	D5	D4	D3	D2	D1	D0
FIELD NAME		CHIP[3:0]				REV[3:0]			
READ/WRITE		R	R	R	R	R	R	R	R
RESET VALUE	TPS65217A	0	1	1	1	0	0	1	0
	TPS65217B	1	1	1	1	0	0	1	0
	TPS65217C	1	1	1	0	0	0	1	0
	TPS65217D	0	1	1	0	0	0	1	0

**Table 1. Chip ID Register (CHIPID) Field Descriptions**

Bit	Field	Type	Reset	Description
D7-D4	CHIP[3:0]	R	TPS65217A: 0111 TPS65217B: 1111 TPS65217C: 1110 TPS65217D: 0110	Chip ID 0000 – Future use 0001 – Future use 0110 – TPS65217D 0111 – TPS65217A 1000 – Future use ... 1110 – TPS65217C 1111 – TPS65217B
D3-D0	REV[3:0]	R	0010	Revision code 0000 – revision 1.0 0001 – revision 1.1 0010 – revision 1.2 ... 1111 – future use

### 9.6.3 Power Path Control Register (PPATH)

**Figure 26. Power Path Control Register (PPATH)  
Address – 0x01h**

DATA BIT	D7	D6	D5	D4	D3	D2	D1	D0
FIELD NAME	ACSINK	USBSINK	AC_EN	USB_EN	IAC[1:0]		IUSB[1:0]	
READ/WRITE	R/W	R/W	R/W	R/W	R/W	R/W	R/W	R/W
RESET VALUE	0	0	1	1	1	1	0	1

**Table 2. Power Path Control Register (PPATH) Field Descriptions**

Bit	Field	Type	Reset	Description
D7	ACSINK	R/W	0	AC current sink control 0 – AC sink is enabled when USB is valid supply and $V_{AC}$ is below detection threshold 1 – Set [ACSINK, USBSINK] = 11 to force both (AC and USB) current sinks OFF NOTE: [ACSINK, USBSINK] = 01b and 10b combinations are not recommended as these may lead to unexpected enabling and disabling of the current sinks.
D6	USBSINK	R/W	1	USB current sink control 0 – USB sink is enabled when AC is valid supply and $V_{USB}$ is below detection threshold 1 – Set [ACSINK, USBSINK] = 11 to force both (AC and USB) current sinks OFF NOTE: [ACSINK, USBSINK] = 01b and 10b combinations are not recommended as these may lead to unexpected enabling and disabling of the current sinks.
D5	AC_EN	R/W	1	AC power path enable 0 – AC power input is turned off 1 – AC power input is turned on
D4	USB_EN	R/W	1	USB power path enable 0 – USB power input is turned off (USB suspend mode) 1 – USB power input is turned on
D3-D2	IAC[1:0]	R/W	1	AC input current limit 00 – 100 mA 01 – 500 mA 10 – 1300 mA 11 – 2500 mA
D1-D0	IUSB[1:0]	R/W	1	USB input current limit 00 – 100 mA 01 – 500 mA 10 – 1300 mA 11 – 1800 mA

### 9.6.4 Interrupt Register (INT)

**Figure 27. Interrupt Register (INT)  
Address – 0x02h**

DATA BIT	D7	D6	D5	D4	D3	D2	D1	D0
FIELD NAME	not used	PBM	ACM	USBM	not used	PBI	ACI	USBI
READ/WRITE	R/W	R/W	R/W	R/W	R	R	R	R
RESET VALUE	1	0	0	0	0	0	0	0

**Table 3. Interrupt Register (INT) Field Descriptions**

Bit	Field	Type	Reset	Description
D7	Reserved	R/W	1	
D6	PBM	R/W	0	Pushbutton status change interrupt mask 0 – interrupt is issued when PB status changes 1 – no interrupt is issued when PB status changes
D5	ACM	R/W	0	AC interrupt mask 0 – interrupt is issued when power to AC input is applied or removed 1 – no interrupt is issued when power to AC input is applied or removed
D4	USBM	R/W	0	USB power status change interrupt mask 0 – interrupt is issued when power to USB input is applied or removed 1 – no interrupt is issued when power to USB input is applied or removed
D3	Reserved	R	0	
D2	PBI	R	0	Push-button status change interrupt 0 – no change in status 1 – pushbutton status change (PB_IN changed high to low or low to high) NOTE: Status information is available in STATUS register
D1	ACI	R	0	AC power status change interrupt 0 – no change in status 1 – AC power status change (power to AC pin has either been applied or removed) NOTE: Status information is available in STATUS register
D0	USBI	R	0	USB power status change interrupt 0 – no change in status 1 – USB power status change (power to USB pin has either been applied or removed) NOTE: Status information is available in STATUS register

### 9.6.5 Charger Configuration Register 0 (CHGCONFIG0)

**Figure 28. Charger Configuration Register 0 (CHGCONFIG0)  
Address – 0x03h**

DATA BIT	D7	D6	D5	D4	D3	D2	D1	D0
FIELD NAME	TREG	DPPM	TSUSP	TERMI	ACTIVE	CHGTOUT	PCHGTOUT	BATTEMP
READ/WRITE	R	R	R	R	R	R	R	R
RESET VALUE	0	0	0	0	0	0	0	0

**Table 4. Charger Configuration Register 0 (CHGCONFIG0) Field Descriptions**

Bit	Field	Type	Reset	Description
D7	TREG	R	0	Thermal regulation 0 – charger is in normal operation 1 – charge current is reduced due to high chip temperature
D6	DPPM	R	0	DPPM active 0 – DPPM loop is not active 1 – DPPM loop is active; charge current is reduced to support the load with the current required
D5	TSUSP	R	0	Thermal suspend 0 – charging is allowed 1 – charging is momentarily suspended because battery temperature is out of range
D4	TERMI	R	0	Termination current detect 0 – charging, charge termination current threshold has not been crossed 1 – charge termination current threshold has been crossed and charging has been stopped. This can be due to a battery reaching full capacity or to a battery removal condition.
D3	ACTIVE	R	0	Charger active bit 0 – charger is not charging 1 – charger is charging (DPPM or thermal regulation may be active)
D2	CHGTOUT	R	0	Charge timer time-out 0 – charging, timers did not time out 1 – one of the timers has timed out and charging has been terminated
D1	PCHGTOUT	R	0	Pre-charge timer time-out 0 – charging, pre-charge timer did not time out 1 – pre-charge timer has timed out and charging has been terminated
D0	BATTEMP	R	0	BAT TEMP/NTC ERROR 0 – battery temperature is in the allowed range for charging 1 – no temperature sensor detected or battery temperature outside valid charging range NOTE: This bit does not indicate that the battery temperature is within the valid range for charging.

**9.6.6 Charger Configuration Register 1 (CHGCONFIG1)**
**Figure 29. Charger Configuration Register 1 (CHGCONFIG1)  
Address – 0x04h**

DATA BIT	D7	D6	D5	D4	D3	D2	D1	D0
FIELD NAME	TIMER[1:0]		TMR_EN	NTC_TYPE	RESET	TERM	SUSP	CHG_EN
READ/WRITE	R/W	R/W	R/W	R/W	R/W	R/W	R/W	R/W
RESET VALUE	1	0	1	1	0	0	0	1

**Table 5. Charger Configuration Register 1 (CHGCONFIG1) Field Descriptions**

Bit	Field	Type	Reset	Description
D7-D6	TIMER[1:0]	R/W	10	Charge safety timer setting (fast charge timer) 00 – 4h 01 – 5h 10 – 6h 11 – 8h
D5	TMR_EN	R/W	1	Safety timer enable 0 – pre-charge timer and fast charge timer are disabled 1 – pre-charge timer and fast charge time are enabled
D4	NTC_TYPE	R/W	1	NTC TYPE (for battery temperature measurement) 0 – 100k (curve 1, B = 3960) 1 – 10k (curve 2, B = 3480)
D3	RESET	R/W	0	Charger reset 0 – inactive 1 – Reset active. This Bit must be set and then reset via the serial interface to restart the charge algorithm.
D2	TERM	R/W	0	Charge termination on/off 0 – charge termination enabled, based on timers and termination current 1 – current-based charge termination will not occur and the charger will always be on
D1	SUSP	R/W	0	Suspend charge 0 – Safety Timer and Pre-Charge timers are not suspended 1 – Safety Timer and Pre-Charge timers are suspended
D0	CHG_EN	R/W	1	Charger enable 0 – charger is disabled 1 – charger is enabled

**9.6.7 Charger Configuration Register 2 (CHGCONFIG2)**

**Figure 30. Charger Configuration Register 2 (CHGCONFIG2)  
Address – 0x05h**

DATA BIT	D7	D6	D5	D4	D3	D2	D1	D0
FIELD NAME	DYNTMR	VPRECHG	VOREG[1:0]		reserved	reserved	reserved	reserved
READ/WRITE	R/W	R/W	R/W	R/W	R/W	R/W	R/W	R/W
RESET VALUE	1	0	0	0	0	0	0	0

**Table 6. Charger Configuration Register 2 (CHGCONFIG2) Field Descriptions**

Bit	Field	Type	Reset	Description
D7	DYNTMR	R/W	1	Dynamic timer function 0 – safety timers run with their nominal clock speed 1 – clock speed is divided by 2 if thermal loop or DPPM loop is active
D6	VPRECHG	R/W	0	Precharge voltage 0 – pre-charge to fast charge transition voltage is 2.9 V 1 – pre-charge to fast charge transition voltage is 2.5 V
D5-D4	VOREG[1:0]	R/W	0	Charge voltage selection 00 – 4.10 V 01 – 4.15 V 10 – 4.20 V 11 – 4.25 V
D3-D0	Reserved	R	0	

**9.6.8 Charger Configuration Register 3 (CHGCONFIG3)**
**Figure 31. Charger Configuration Register 3 (CHGCONFIG3)  
Address – 0x06h**

DATA BIT	D7	D6	D5	D4	D3	D2	D1	D0
FIELD NAME	ICHRG[1:0]		DPPMTH[1:0]		PCHRG	TERMIF[1:0]		TRANGE
READ/WRITE	R/W	R/W	R/W	R/W	R/W	R/W	R/W	R/W
RESET VALUE	1	0	1	1	0	0	1	0

**Table 7. Charger Configuration Register 3 (CHGCONFIG3) Field Descriptions**

Bit	Field	Type	Reset	Description
D7-D6	ICHRG[1:0]	R/W	10	Charge current setting 00 – 300 mA 01 – 400 mA 10 – 500 mA 11 – 700 mA
D5-D4	DPPMTH[1:0]	R/W	11	Power path DPPM threshold 00 – 3.5 V 01 – 3.75 V 10 – 4.0 V 11 – 4.25 V
D3	PCHRG	R/W	0	Pre-charge time 0 – 30 min 1 – 60 min
D2-D1	TERMIF[1:0]	R/W	01	Termination current factor 00 – 2.5% 01 – 7.5% 10 – 15% 11 – 18% NOTE: Termination current = TERMIF x ICHRG
D0	TRANGE	R/W	0	Temperature range for charging 0 – 0°C-45°C 1 – 0°C-60°C



**9.6.9 WLED Control Register 1 (WLEDCTRL1)**

**Figure 32. WLED Control Register 1 (WLEDCTRL1)  
Address – 0x07h**

DATA BIT	D7	D6	D5	D4	D3	D2	D1	D0
FIELD NAME	not used	not used	not used	not used	ISINK_EN	ISEL	FDIM[1:0]	
READ/WRITE	R/W	R/W	R/W	R/W	R/W	R/W	R/W	R/W
RESET VALUE	0	0	0	0	0	0	0	1

**Table 8. WLED Control Register 1 (WLEDCTRL1) Field Descriptions**

Bit	Field	Type	Reset	Description
D7-D4	Reserved	R/W	0	
D3	ISINK_EN	R/W	0	Current sink enable 0 – current sink is disabled (OFF) 1 – current sink is enabled (ON) NOTE: This bit enables both current sinks
D2	ISEL	R/W	0	ISET selection bit 0 – low-level (define by ISET1 pin) 1 – high-level (defined by ISET2 pin)
D1-D0	FDIM[1:0]	R/W	1	PWM dimming frequency 00 – 100 Hz 01 – 200 Hz 10 – 500 Hz 11 – 1000 Hz

**9.6.10 WLED Control Register 2 (WLEDCTRL2)**
**Figure 33. WLED Control Register 2 (WLEDCTRL2)  
Address – 0x08h**

DATA BIT	D7	D6	D5	D4	D3	D2	D1	D0
FIELD NAME	not used	DUTY[6:0]						
READ/WRITE	R/W	R/W	R/W	R/W	R/W	R/W	R/W	R/W
RESET VALUE	0	0	0	0	0	0	0	0

**Table 9. WLED Control Register 2 (WLEDCTRL2) Field Descriptions**

Bit	Field	Type	Reset	Description
D7	Reserved	R/W	0	
D6-D0	DUTY[6:0]	R/W	0	000 0000 – 1% 000 0001 – 2% ... 110 0010 – 99% 110 0011 – 100% 110 0100 – 0% ... 111 1110 – 0% 111 1111 – 0%

**9.6.11 MUX Control Register (MUXCTRL)**

**Figure 34. MUX Control Register (MUXCTRL)  
Address – 0x09h**

DATA BIT	D7	D6	D5	D4	D3	D2	D1	D0
<b>FIELD NAME</b>	not used	not used	not used	not used	not used	MUX[2:0]		
<b>READ/WRITE</b>	R/W	R/W	R/W	R/W	R/W	R/W	R/W	R/W
<b>RESET VALUE</b>	0	0	0	0	0	0	0	0

**Table 10. MUX Control Register (MUXCTRL) Field Descriptions**

Bit	Field	Type	Reset	Description
D7-D3	Reserved	R/W	0	
D2-D0	MUX[2:0]	R/W	0	Analog multiplexer selection 000 – MUX is disabled, output is HiZ 001 – VBAT 010 – VSYS 011 – VTS 100 – VICHARGE 101 – MUX_IN (external input) 110 – MUX is disabled, output is HiZ 111 – MUX is disabled, output is HiZ

**9.6.12 Status Register (STATUS)**
**Figure 35. Status Register (STATUS)  
Address – 0x0Ah**

DATA BIT	D7	D6	D5	D4	D3	D2	D1	D0
FIELD NAME	OFF	not used	not used	not used	ACPWR	USBPWR	not used	PB
READ/WRITE	R/W	R/W	R/W	R/W	R	R	R	R
RESET VALUE	0	0	0	0	0	0	0	0

**Table 11. Status Register (STATUS) Field Descriptions**

Bit	Field	Type	Reset	Description
D7	OFF	R/W	0	OFF bit. Set this bit to 1 to enter OFF state when PWR_EN pin is pulled low. Bit is automatically reset to 0.
D6-D4	Reserved	R/W	0	
D3	ACPWR	R	0	AC power status bit 0 – AC power is not present and/or not in the range valid for charging 1 – AC source is present and in the range valid for charging
D2	USBPWR	R	0	USB power 0 – USB power is not present and/or not in the range valid for charging 1 – USB source is present and in the range valid for charging
D1	Reserved	R	0	
D0	PB	R	0	Push Button status bit 0 – Push Button is inactive (PB_IN is pulled high) 1 – Push Button is active (PB_IN is pulled low)

**9.6.13 Password Register (PASSWORD)**
**Figure 36. Password Register (PASSWORD)  
Address – 0x0Bh**

DATA BIT	D7	D6	D5	D4	D3	D2	D1	D0
FIELD NAME	PWRD[7:0]							
READ/WRITE	R/W	R/W	R/W	R/W	R/W	R/W	R/W	R/W
RESET VALUE	0	0	0	0	0	0	0	0

**Table 12. Password Register (PASSWORD) Field Descriptions**

Bit	Field	Type	Reset	Description
D7-D0	PWRD[7:0]	R/W	0	0000 0000 – Password protected registers are locked for write access ... 0111 1100 – Password protected registers are locked for write access 0111 1101 – Allows writing to a password protected register in the next write cycle 0111 1110 – Password protected registers are locked for write access ... 1111 1111 – Password protected registers are locked for write access NOTE: Register is automatically reset to 0x00h after following I <sup>2</sup> C transaction. See PASSWORD PROTECTION section for details.

**9.6.14 Power Good Register (PGOOD)**
**Figure 37. Power Good Register (PGOOD)  
Address – 0x0Ch**

DATA BIT	D7	D6	D5	D4	D3	D2	D1	D0
FIELD NAME	not used	LDO3_PG	LDO4_PG	DC1_PG	DC2_PG	DC3_PG	LDO1_PG	LDO2_PG
READ/WRITE	R/W	R	R	R	R	R	R	R
RESET VALUE	0	0	0	0	0	0	0	0

**Table 13. Power Good Register (PGOOD) Field Descriptions**

Bit	Field	Type	Reset	Description
D7	Reserved	R/W	0	
D6	LDO3_PG	R	0	LDO3 power-good 0 – LDO is either disabled or not in regulation 1 – LDO is in regulation or LS1/LDO3 is configured as switch
D5	LDO4_PG	R	0	LDO4 power-good 0 – LDO is either disabled or not in regulation 1 – LDO is in regulation or LS2/LDO4 is configured as switch
D4	DC1_PG	R	0	DCDC1 power-good 0 – DCDC is either disabled or not in regulation 1 – DCDC is in regulation
D3	DC2_PG	R	0	DCDC2 power-good 0 – DCDC is either disabled or not in regulation 1 – DCDC is in regulation
D2	DC3_PG	R	0	DCDC3 power-good 0 – DCDC is either disabled or not in regulation 1 – DCDC is in regulation
D1	LDO1_PG	R	0	LDO1 power-good 0 – LDO is either disabled or not in regulation 1 – LDO is in regulation
D0	LDO2_PG	R	0	LDO2 power-good 0 – LDO is either disabled or not in regulation 1 – LDO is in regulation

**9.6.15 Power Good Control Register (DEFG)**

**Figure 38. Power Good Control Register (DEFG)  
Address – 0x0Dh (Password Protected)**

DATA BIT	D7	D6	D5	D4	D3	D2	D1	D0
FIELD NAME	not used	not used	not used	not used	LDO1PGM	LDO2PGM	PGDLY[1:0]	
READ/WRITE	R/W	R/W	R/W	R/W	R/W	R/W	R/W	R/W
RESET VALUE	0	0	0	0	1	1	0	0

**Table 14. Power Good Control Register (DEFG) Field Descriptions**

Bit	Field	Type	Reset	Description
D7-D4	Reserved	R/W	0	
D3	LDO1PGM	R/W	1	LDO1 power-good masking bit 0 – PGOOD pin is pulled low if LDO1_PG is low 1 – LDO1_PG status does not affect the status of the PGOOD output pin
D2	LDO2PGM	R/W	1	LDO2 power-good masking bit 0 – PGOOD pin is pulled low if LDO2_PG is low 1 – LDO2_PG status does not affect the status of the PGOOD output pin
D1-D0	PGDLY[1:0]	R/W	0	Power Good delay 00 – 20 ms 01 – 100 ms 10 – 200 ms 11 – 400 ms Note: PGDLY applies to PGOOD pin.

**9.6.16 DCDC1 Control Register (DEFDCDC1)**
**Figure 39. DCDC1 Control Register (DEFDCDC1)  
Address – 0x0Eh (Password Protected)**

DATA BIT		D7	D6	D5	D4	D3	D2	D1	D0
FIELD NAME		XADJ1	not used	DCDC1[5:0]					
READ/WRITE		R/W	R/W	R/W	R/W	R/W	R/W	R/W	R/W
RESET VALUE	TPS65217A	0	0	0	1	1	1	1	0
	TPS65217B	0	0	0	1	1	1	1	0
	TPS65217C	0	0	0	1	1	0	0	0
	TPS65217D	0	0	0	1	0	0	1	0

**Table 15. DCDC1 Control Register (DEFDCDC1) Field Descriptions**

Bit	Field	Type	Reset	Description																																																																
D7	XADJ1	R/W	0	DCDC1 voltage adjustment option 0 – Output voltage is adjusted through register setting 1 – Output voltage is externally adjusted																																																																
D6	Reserved	R/W	0																																																																	
D5-D0	DCDC1[5:0]	R/W	TPS65217A: 0111 TPS65217B: 0111 TPS65217C: 0110 TPS65217D: 0100	DCDC1 output voltage setting <table border="1" style="width: 100%; border-collapse: collapse;"> <tr> <td>00 0000 – 0.900 V</td> <td>01 0000 – 1.300 V</td> <td>10 0000 – 1.900 V</td> <td>11 0000 – 2.700 V</td> </tr> <tr> <td>00 0001 – 0.925 V</td> <td>01 0001 – 1.325 V</td> <td>10 0001 – 1.950 V</td> <td>11 0001 – 2.750 V</td> </tr> <tr> <td>00 0010 – 0.950 V</td> <td>01 0010 – 1.350 V</td> <td>10 0010 – 2.000 V</td> <td>11 0010 – 2.800 V</td> </tr> <tr> <td>00 0011 – 0.975 V</td> <td>01 0011 – 1.375 V</td> <td>10 0011 – 2.050 V</td> <td>11 0011 – 2.850 V</td> </tr> <tr> <td>00 0100 – 1.000 V</td> <td>01 0100 – 1.400 V</td> <td>10 0100 – 2.100 V</td> <td>11 0100 – 2.900 V</td> </tr> <tr> <td>00 0101 – 1.025 V</td> <td>01 0101 – 1.425 V</td> <td>10 0101 – 2.150 V</td> <td>11 0101 – 3.000 V</td> </tr> <tr> <td>00 0110 – 1.050 V</td> <td>01 0110 – 1.450 V</td> <td>10 0110 – 2.200 V</td> <td>11 0110 – 3.100 V</td> </tr> <tr> <td>00 0111 – 1.075 V</td> <td>01 0111 – 1.475 V</td> <td>10 0111 – 2.250 V</td> <td>11 0111 – 3.200 V</td> </tr> <tr> <td>00 1000 – 1.100 V</td> <td>01 1000 – 1.500 V</td> <td>10 1000 – 2.300 V</td> <td>11 1000 – 3.300 V</td> </tr> <tr> <td>00 1001 – 1.125 V</td> <td>01 1001 – 1.550 V</td> <td>10 1001 – 2.350 V</td> <td>11 1001 – 3.300 V</td> </tr> <tr> <td>00 1010 – 1.150 V</td> <td>01 1010 – 1.600 V</td> <td>10 1010 – 2.400 V</td> <td>11 1010 – 3.300 V</td> </tr> <tr> <td>00 1011 – 1.175 V</td> <td>01 1011 – 1.650 V</td> <td>10 1011 – 2.450 V</td> <td>11 1011 – 3.300 V</td> </tr> <tr> <td>00 1100 – 1.200 V</td> <td>01 1100 – 1.700 V</td> <td>10 1100 – 2.500 V</td> <td>11 1100 – 3.300 V</td> </tr> <tr> <td>00 1101 – 1.225 V</td> <td>01 1101 – 1.750 V</td> <td>10 1101 – 2.550 V</td> <td>11 1101 – 3.300 V</td> </tr> <tr> <td>00 1110 – 1.250 V</td> <td>01 1110 – 1.800 V</td> <td>10 1110 – 2.600 V</td> <td>11 1110 – 3.300 V</td> </tr> <tr> <td>00 1111 – 1.275 V</td> <td>01 1111 – 1.850 V</td> <td>10 1111 – 2.650 V</td> <td>11 1111 – 3.300 V</td> </tr> </table>	00 0000 – 0.900 V	01 0000 – 1.300 V	10 0000 – 1.900 V	11 0000 – 2.700 V	00 0001 – 0.925 V	01 0001 – 1.325 V	10 0001 – 1.950 V	11 0001 – 2.750 V	00 0010 – 0.950 V	01 0010 – 1.350 V	10 0010 – 2.000 V	11 0010 – 2.800 V	00 0011 – 0.975 V	01 0011 – 1.375 V	10 0011 – 2.050 V	11 0011 – 2.850 V	00 0100 – 1.000 V	01 0100 – 1.400 V	10 0100 – 2.100 V	11 0100 – 2.900 V	00 0101 – 1.025 V	01 0101 – 1.425 V	10 0101 – 2.150 V	11 0101 – 3.000 V	00 0110 – 1.050 V	01 0110 – 1.450 V	10 0110 – 2.200 V	11 0110 – 3.100 V	00 0111 – 1.075 V	01 0111 – 1.475 V	10 0111 – 2.250 V	11 0111 – 3.200 V	00 1000 – 1.100 V	01 1000 – 1.500 V	10 1000 – 2.300 V	11 1000 – 3.300 V	00 1001 – 1.125 V	01 1001 – 1.550 V	10 1001 – 2.350 V	11 1001 – 3.300 V	00 1010 – 1.150 V	01 1010 – 1.600 V	10 1010 – 2.400 V	11 1010 – 3.300 V	00 1011 – 1.175 V	01 1011 – 1.650 V	10 1011 – 2.450 V	11 1011 – 3.300 V	00 1100 – 1.200 V	01 1100 – 1.700 V	10 1100 – 2.500 V	11 1100 – 3.300 V	00 1101 – 1.225 V	01 1101 – 1.750 V	10 1101 – 2.550 V	11 1101 – 3.300 V	00 1110 – 1.250 V	01 1110 – 1.800 V	10 1110 – 2.600 V	11 1110 – 3.300 V	00 1111 – 1.275 V	01 1111 – 1.850 V	10 1111 – 2.650 V	11 1111 – 3.300 V
00 0000 – 0.900 V	01 0000 – 1.300 V	10 0000 – 1.900 V	11 0000 – 2.700 V																																																																	
00 0001 – 0.925 V	01 0001 – 1.325 V	10 0001 – 1.950 V	11 0001 – 2.750 V																																																																	
00 0010 – 0.950 V	01 0010 – 1.350 V	10 0010 – 2.000 V	11 0010 – 2.800 V																																																																	
00 0011 – 0.975 V	01 0011 – 1.375 V	10 0011 – 2.050 V	11 0011 – 2.850 V																																																																	
00 0100 – 1.000 V	01 0100 – 1.400 V	10 0100 – 2.100 V	11 0100 – 2.900 V																																																																	
00 0101 – 1.025 V	01 0101 – 1.425 V	10 0101 – 2.150 V	11 0101 – 3.000 V																																																																	
00 0110 – 1.050 V	01 0110 – 1.450 V	10 0110 – 2.200 V	11 0110 – 3.100 V																																																																	
00 0111 – 1.075 V	01 0111 – 1.475 V	10 0111 – 2.250 V	11 0111 – 3.200 V																																																																	
00 1000 – 1.100 V	01 1000 – 1.500 V	10 1000 – 2.300 V	11 1000 – 3.300 V																																																																	
00 1001 – 1.125 V	01 1001 – 1.550 V	10 1001 – 2.350 V	11 1001 – 3.300 V																																																																	
00 1010 – 1.150 V	01 1010 – 1.600 V	10 1010 – 2.400 V	11 1010 – 3.300 V																																																																	
00 1011 – 1.175 V	01 1011 – 1.650 V	10 1011 – 2.450 V	11 1011 – 3.300 V																																																																	
00 1100 – 1.200 V	01 1100 – 1.700 V	10 1100 – 2.500 V	11 1100 – 3.300 V																																																																	
00 1101 – 1.225 V	01 1101 – 1.750 V	10 1101 – 2.550 V	11 1101 – 3.300 V																																																																	
00 1110 – 1.250 V	01 1110 – 1.800 V	10 1110 – 2.600 V	11 1110 – 3.300 V																																																																	
00 1111 – 1.275 V	01 1111 – 1.850 V	10 1111 – 2.650 V	11 1111 – 3.300 V																																																																	



**9.6.17 DCDC2 Control Register (DEFDCDC2)**
**Figure 40. DCDC2 Control Register (DEFDCDC2)  
Address – 0x0Fh (Password Protected)**

DATA BIT		D7	D6	D5	D4	D3	D2	D1	D0
FIELD NAME		XADJ2	not used	DCDC2[5:0]					
READ/WRITE		R/W	R/W	R/W	R/W	R/W	R/W	R/W	R/W
RESET VALUE	TPS65217A	0	0	1	1	1	0	0	0
	TPS65217B	0	0	0	0	1	0	0	0
	TPS65217C	0	0	0	0	1	0	0	0
	TPS65217D	0	0	0	0	1	0	0	0

**Table 16. DCDC2 Control Register (DEFDCDC2) Field Descriptions**

Bit	Field	Type	Reset	Description																																																																
D7	XADJ2	R/W	0	DCDC2 voltage adjustment option 0 – Output voltage is adjusted through register setting 1 – Output voltage is externally adjusted																																																																
D6	Reserved	R/W	0																																																																	
D5-D0	DCDC2[5:0]	R/W	TPS65217A: 1110 TPS65217B: 0010 TPS65217C: 0010 TPS65217D: 0010	DCDC2 output voltage setting <table border="1" style="width: 100%; border-collapse: collapse;"> <tr> <td>00 0000 – 0.900 V</td> <td>01 0000 – 1.300 V</td> <td>10 0000 – 1.900 V</td> <td>11 0000 – 2.700 V</td> </tr> <tr> <td>00 0001 – 0.925 V</td> <td>01 0001 – 1.325 V</td> <td>10 0001 – 1.950 V</td> <td>11 0001 – 2.750 V</td> </tr> <tr> <td>00 0010 – 0.950 V</td> <td>01 0010 – 1.350 V</td> <td>10 0010 – 2.000 V</td> <td>11 0010 – 2.800 V</td> </tr> <tr> <td>00 0011 – 0.975 V</td> <td>01 0011 – 1.375 V</td> <td>10 0011 – 2.050 V</td> <td>11 0011 – 2.850 V</td> </tr> <tr> <td>00 0100 – 1.000 V</td> <td>01 0100 – 1.400 V</td> <td>10 0100 – 2.100 V</td> <td>11 0100 – 2.900 V</td> </tr> <tr> <td>00 0101 – 1.025 V</td> <td>01 0101 – 1.425 V</td> <td>10 0101 – 2.150 V</td> <td>11 0101 – 3.000 V</td> </tr> <tr> <td>00 0110 – 1.050 V</td> <td>01 0110 – 1.450 V</td> <td>10 0110 – 2.200 V</td> <td>11 0110 – 3.100 V</td> </tr> <tr> <td>00 0111 – 1.075 V</td> <td>01 0111 – 1.475 V</td> <td>10 0111 – 2.250 V</td> <td>11 0111 – 3.200 V</td> </tr> <tr> <td>00 1000 – 1.100 V</td> <td>01 1000 – 1.500 V</td> <td>10 1000 – 2.300 V</td> <td>11 1000 – 3.300 V</td> </tr> <tr> <td>00 1001 – 1.125 V</td> <td>01 1001 – 1.550 V</td> <td>10 1001 – 2.350 V</td> <td>11 1001 – 3.300 V</td> </tr> <tr> <td>00 1010 – 1.150 V</td> <td>01 1010 – 1.600 V</td> <td>10 1010 – 2.400 V</td> <td>11 1010 – 3.300 V</td> </tr> <tr> <td>00 1011 – 1.175 V</td> <td>01 1011 – 1.650 V</td> <td>10 1011 – 2.450 V</td> <td>11 1011 – 3.300 V</td> </tr> <tr> <td>00 1100 – 1.200 V</td> <td>01 1100 – 1.700 V</td> <td>10 1100 – 2.500 V</td> <td>11 1100 – 3.300 V</td> </tr> <tr> <td>00 1101 – 1.225 V</td> <td>01 1101 – 1.750 V</td> <td>10 1101 – 2.550 V</td> <td>11 1101 – 3.300 V</td> </tr> <tr> <td>00 1110 – 1.250 V</td> <td>01 1110 – 1.800 V</td> <td>10 1110 – 2.600 V</td> <td>11 1110 – 3.300 V</td> </tr> <tr> <td>00 1111 – 1.275 V</td> <td>01 1111 – 1.850 V</td> <td>10 1111 – 2.650 V</td> <td>11 1111 – 3.300 V</td> </tr> </table>	00 0000 – 0.900 V	01 0000 – 1.300 V	10 0000 – 1.900 V	11 0000 – 2.700 V	00 0001 – 0.925 V	01 0001 – 1.325 V	10 0001 – 1.950 V	11 0001 – 2.750 V	00 0010 – 0.950 V	01 0010 – 1.350 V	10 0010 – 2.000 V	11 0010 – 2.800 V	00 0011 – 0.975 V	01 0011 – 1.375 V	10 0011 – 2.050 V	11 0011 – 2.850 V	00 0100 – 1.000 V	01 0100 – 1.400 V	10 0100 – 2.100 V	11 0100 – 2.900 V	00 0101 – 1.025 V	01 0101 – 1.425 V	10 0101 – 2.150 V	11 0101 – 3.000 V	00 0110 – 1.050 V	01 0110 – 1.450 V	10 0110 – 2.200 V	11 0110 – 3.100 V	00 0111 – 1.075 V	01 0111 – 1.475 V	10 0111 – 2.250 V	11 0111 – 3.200 V	00 1000 – 1.100 V	01 1000 – 1.500 V	10 1000 – 2.300 V	11 1000 – 3.300 V	00 1001 – 1.125 V	01 1001 – 1.550 V	10 1001 – 2.350 V	11 1001 – 3.300 V	00 1010 – 1.150 V	01 1010 – 1.600 V	10 1010 – 2.400 V	11 1010 – 3.300 V	00 1011 – 1.175 V	01 1011 – 1.650 V	10 1011 – 2.450 V	11 1011 – 3.300 V	00 1100 – 1.200 V	01 1100 – 1.700 V	10 1100 – 2.500 V	11 1100 – 3.300 V	00 1101 – 1.225 V	01 1101 – 1.750 V	10 1101 – 2.550 V	11 1101 – 3.300 V	00 1110 – 1.250 V	01 1110 – 1.800 V	10 1110 – 2.600 V	11 1110 – 3.300 V	00 1111 – 1.275 V	01 1111 – 1.850 V	10 1111 – 2.650 V	11 1111 – 3.300 V
00 0000 – 0.900 V	01 0000 – 1.300 V	10 0000 – 1.900 V	11 0000 – 2.700 V																																																																	
00 0001 – 0.925 V	01 0001 – 1.325 V	10 0001 – 1.950 V	11 0001 – 2.750 V																																																																	
00 0010 – 0.950 V	01 0010 – 1.350 V	10 0010 – 2.000 V	11 0010 – 2.800 V																																																																	
00 0011 – 0.975 V	01 0011 – 1.375 V	10 0011 – 2.050 V	11 0011 – 2.850 V																																																																	
00 0100 – 1.000 V	01 0100 – 1.400 V	10 0100 – 2.100 V	11 0100 – 2.900 V																																																																	
00 0101 – 1.025 V	01 0101 – 1.425 V	10 0101 – 2.150 V	11 0101 – 3.000 V																																																																	
00 0110 – 1.050 V	01 0110 – 1.450 V	10 0110 – 2.200 V	11 0110 – 3.100 V																																																																	
00 0111 – 1.075 V	01 0111 – 1.475 V	10 0111 – 2.250 V	11 0111 – 3.200 V																																																																	
00 1000 – 1.100 V	01 1000 – 1.500 V	10 1000 – 2.300 V	11 1000 – 3.300 V																																																																	
00 1001 – 1.125 V	01 1001 – 1.550 V	10 1001 – 2.350 V	11 1001 – 3.300 V																																																																	
00 1010 – 1.150 V	01 1010 – 1.600 V	10 1010 – 2.400 V	11 1010 – 3.300 V																																																																	
00 1011 – 1.175 V	01 1011 – 1.650 V	10 1011 – 2.450 V	11 1011 – 3.300 V																																																																	
00 1100 – 1.200 V	01 1100 – 1.700 V	10 1100 – 2.500 V	11 1100 – 3.300 V																																																																	
00 1101 – 1.225 V	01 1101 – 1.750 V	10 1101 – 2.550 V	11 1101 – 3.300 V																																																																	
00 1110 – 1.250 V	01 1110 – 1.800 V	10 1110 – 2.600 V	11 1110 – 3.300 V																																																																	
00 1111 – 1.275 V	01 1111 – 1.850 V	10 1111 – 2.650 V	11 1111 – 3.300 V																																																																	

**9.6.18 DCDC3 Control Register (DEFDCDC3)**
**Figure 41. DCDC3 Control Register (DEFDCDC3)  
Address – 0x10h (Password Protected)**

DATA BIT	D7	D6	D5	D4	D3	D2	D1	D0
FIELD NAME	XADJ3	not used	DCDC3[5:0]					
READ/WRITE	R/W	R/W	R/W	R/W	R/W	R/W	R/W	R/W
RESET VALUE	0	0	0	0	1	0	0	0

**Table 17. DCDC3 Control Register (DEFDCDC3) Field Descriptions**

Bit	Field	Type	Reset	Description																																																																
D7	XADJ3	R/W	0	DCDC3 voltage adjustment option 0 – Output voltage is adjusted through register setting 1 – Output voltage is externally adjusted																																																																
D6	Reserved	R/W	0																																																																	
D5-D0	DCDC3[5:0]	R/W	1000	DCDC3 output voltage setting <table border="1" style="width: 100%; border-collapse: collapse;"> <tr> <td>00 0000 – 0.900 V</td> <td>01 0000 – 1.300 V</td> <td>10 0000 – 1.900 V</td> <td>11 0000 – 2.700 V</td> </tr> <tr> <td>00 0001 – 0.925 V</td> <td>01 0001 – 1.325 V</td> <td>10 0001 – 1.950 V</td> <td>11 0001 – 2.750 V</td> </tr> <tr> <td>00 0010 – 0.950 V</td> <td>01 0010 – 1.350 V</td> <td>10 0010 – 2.000 V</td> <td>11 0010 – 2.800 V</td> </tr> <tr> <td>00 0011 – 0.975 V</td> <td>01 0011 – 1.375 V</td> <td>10 0011 – 2.050 V</td> <td>11 0011 – 2.850 V</td> </tr> <tr> <td>00 0100 – 1.000 V</td> <td>01 0100 – 1.400 V</td> <td>10 0100 – 2.100 V</td> <td>11 0100 – 2.900 V</td> </tr> <tr> <td>00 0101 – 1.025 V</td> <td>01 0101 – 1.425 V</td> <td>10 0101 – 2.150 V</td> <td>11 0101 – 3.000 V</td> </tr> <tr> <td>00 0110 – 1.050 V</td> <td>01 0110 – 1.450 V</td> <td>10 0110 – 2.200 V</td> <td>11 0110 – 3.100 V</td> </tr> <tr> <td>00 0111 – 1.075 V</td> <td>01 0111 – 1.475 V</td> <td>10 0111 – 2.250 V</td> <td>11 0111 – 3.200 V</td> </tr> <tr> <td>00 1000 – 1.100 V</td> <td>01 1000 – 1.500 V</td> <td>10 1000 – 2.300 V</td> <td>11 1000 – 3.300 V</td> </tr> <tr> <td>00 1001 – 1.125 V</td> <td>01 1001 – 1.550 V</td> <td>10 1001 – 2.350 V</td> <td>11 1001 – 3.300 V</td> </tr> <tr> <td>00 1010 – 1.150 V</td> <td>01 1010 – 1.600 V</td> <td>10 1010 – 2.400 V</td> <td>11 1010 – 3.300 V</td> </tr> <tr> <td>00 1011 – 1.175 V</td> <td>01 1011 – 1.650 V</td> <td>10 1011 – 2.450 V</td> <td>11 1011 – 3.300 V</td> </tr> <tr> <td>00 1100 – 1.200 V</td> <td>01 1100 – 1.700 V</td> <td>10 1100 – 2.500 V</td> <td>11 1100 – 3.300 V</td> </tr> <tr> <td>00 1101 – 1.225 V</td> <td>01 1101 – 1.750 V</td> <td>10 1101 – 2.550 V</td> <td>11 1101 – 3.300 V</td> </tr> <tr> <td>00 1110 – 1.250 V</td> <td>01 1110 – 1.800 V</td> <td>10 1110 – 2.600 V</td> <td>11 1110 – 3.300 V</td> </tr> <tr> <td>00 1111 – 1.275 V</td> <td>01 1111 – 1.850 V</td> <td>10 1111 – 2.650 V</td> <td>11 1111 – 3.300 V</td> </tr> </table>	00 0000 – 0.900 V	01 0000 – 1.300 V	10 0000 – 1.900 V	11 0000 – 2.700 V	00 0001 – 0.925 V	01 0001 – 1.325 V	10 0001 – 1.950 V	11 0001 – 2.750 V	00 0010 – 0.950 V	01 0010 – 1.350 V	10 0010 – 2.000 V	11 0010 – 2.800 V	00 0011 – 0.975 V	01 0011 – 1.375 V	10 0011 – 2.050 V	11 0011 – 2.850 V	00 0100 – 1.000 V	01 0100 – 1.400 V	10 0100 – 2.100 V	11 0100 – 2.900 V	00 0101 – 1.025 V	01 0101 – 1.425 V	10 0101 – 2.150 V	11 0101 – 3.000 V	00 0110 – 1.050 V	01 0110 – 1.450 V	10 0110 – 2.200 V	11 0110 – 3.100 V	00 0111 – 1.075 V	01 0111 – 1.475 V	10 0111 – 2.250 V	11 0111 – 3.200 V	00 1000 – 1.100 V	01 1000 – 1.500 V	10 1000 – 2.300 V	11 1000 – 3.300 V	00 1001 – 1.125 V	01 1001 – 1.550 V	10 1001 – 2.350 V	11 1001 – 3.300 V	00 1010 – 1.150 V	01 1010 – 1.600 V	10 1010 – 2.400 V	11 1010 – 3.300 V	00 1011 – 1.175 V	01 1011 – 1.650 V	10 1011 – 2.450 V	11 1011 – 3.300 V	00 1100 – 1.200 V	01 1100 – 1.700 V	10 1100 – 2.500 V	11 1100 – 3.300 V	00 1101 – 1.225 V	01 1101 – 1.750 V	10 1101 – 2.550 V	11 1101 – 3.300 V	00 1110 – 1.250 V	01 1110 – 1.800 V	10 1110 – 2.600 V	11 1110 – 3.300 V	00 1111 – 1.275 V	01 1111 – 1.850 V	10 1111 – 2.650 V	11 1111 – 3.300 V
00 0000 – 0.900 V	01 0000 – 1.300 V	10 0000 – 1.900 V	11 0000 – 2.700 V																																																																	
00 0001 – 0.925 V	01 0001 – 1.325 V	10 0001 – 1.950 V	11 0001 – 2.750 V																																																																	
00 0010 – 0.950 V	01 0010 – 1.350 V	10 0010 – 2.000 V	11 0010 – 2.800 V																																																																	
00 0011 – 0.975 V	01 0011 – 1.375 V	10 0011 – 2.050 V	11 0011 – 2.850 V																																																																	
00 0100 – 1.000 V	01 0100 – 1.400 V	10 0100 – 2.100 V	11 0100 – 2.900 V																																																																	
00 0101 – 1.025 V	01 0101 – 1.425 V	10 0101 – 2.150 V	11 0101 – 3.000 V																																																																	
00 0110 – 1.050 V	01 0110 – 1.450 V	10 0110 – 2.200 V	11 0110 – 3.100 V																																																																	
00 0111 – 1.075 V	01 0111 – 1.475 V	10 0111 – 2.250 V	11 0111 – 3.200 V																																																																	
00 1000 – 1.100 V	01 1000 – 1.500 V	10 1000 – 2.300 V	11 1000 – 3.300 V																																																																	
00 1001 – 1.125 V	01 1001 – 1.550 V	10 1001 – 2.350 V	11 1001 – 3.300 V																																																																	
00 1010 – 1.150 V	01 1010 – 1.600 V	10 1010 – 2.400 V	11 1010 – 3.300 V																																																																	
00 1011 – 1.175 V	01 1011 – 1.650 V	10 1011 – 2.450 V	11 1011 – 3.300 V																																																																	
00 1100 – 1.200 V	01 1100 – 1.700 V	10 1100 – 2.500 V	11 1100 – 3.300 V																																																																	
00 1101 – 1.225 V	01 1101 – 1.750 V	10 1101 – 2.550 V	11 1101 – 3.300 V																																																																	
00 1110 – 1.250 V	01 1110 – 1.800 V	10 1110 – 2.600 V	11 1110 – 3.300 V																																																																	
00 1111 – 1.275 V	01 1111 – 1.850 V	10 1111 – 2.650 V	11 1111 – 3.300 V																																																																	

**9.6.19 Slew Rate Control Register (DEFSLEW)**
**Figure 42. Slew Rate Control Register (DEFSLEW)  
Address – 0x11h (Password Protected)**

DATA BIT	D7	D6	D5	D4	D3	D2	D1	D0
FIELD NAME	GO	GODSBL	PFM_EN1	PFM_EN2	PFM_EN3	SLEW[2:0]		
READ/WRITE	R/W	R/W	R/W	R/W	R/W	R/W	R/W	R/W
RESET VALUE	0	0	0	0	0	1	1	0

**Table 18. Slew Rate Control Register (DEFSLEW) Field Descriptions**

Bit	Field	Type	Reset	Description <sup>(1)</sup>
D7	GO	R/W	0	Go bit 0 – no change 1 – Initiates the transition from present state to the output voltage setting currently stored in DEFDCDCx register NOTE: Bit is automatically reset at the end of the voltage transition.
D6	GODSBL	R/W	0	Go disable bit 0 – enabled 1 – disabled; DCDCx output voltage changes whenever set-point is updated in DEFDCDCx register without having to write to the GO bit. SLEW[2:0] setting does apply.
D5	PFM_EN1	R/W	0	PFM enable bit, DCDC1 0 – DCDC converter operates in PWM / PFM mode, depending on load 1 – DCDC converter is forced into fixed frequency PWM mode
D4	PFM_EN2	R/W	0	PFM enable bit, DCDC2 0 – DCDC converter operates in PWM / PFM mode, depending on load 1 – DCDC converter is forced into fixed frequency PWM mode
D3	PFM_EN3	R/W	0	PFM enable bit, DCDC3 0 – DCDC converter operates in PWM / PFM mode, depending on load 1 – DCDC converter is forced into fixed frequency PWM mode
D2-D0	SLEW[2:0]	R/W	0110	Output slew rate setting 000 – 224 $\mu$ s/step (0.11 mV/ $\mu$ s at 25 mV per step) 001 – 112 $\mu$ s/step (0.22 mV/ $\mu$ s at 25 mV per step) 010 – 56 $\mu$ s/step (0.45 mV/ $\mu$ s at 25 mV per step) 011 – 28 $\mu$ s/step (0.90 mV/ $\mu$ s at 25 mV per step) 100 – 14 $\mu$ s/step (1.80 mV/ $\mu$ s at 25 mV per step) 101 – 7 $\mu$ s/step (3.60 mV/ $\mu$ s at 25 mV per step) 110 – 3.5 $\mu$ s/step (7.2 mV/ $\mu$ s at 25 mV per step) 111 – Immediate; Slew rate is only limited by control loop response time  Note: The actual slew rate depends on the voltage step per code. Please refer to DCDC1 and DCDC2 register for details.

(1) Slew-rate control applies to all three DCDC converters.

**9.6.20 LDO1 Control Register (DEFLDO1)**
**Figure 43. LDO1 Control Register (DEFLDO1)  
Address – 0x12h (Password Protected)**

DATA BIT	D7	D6	D5	D4	D3	D2	D1	D0
FIELD NAME	not used	not used	not used	not used	LDO1[3:0]			
READ/WRITE	R/W	R/W	R/W	R/W	R/W	R/W	R/W	R/W
RESET VALUE	0	0	0	0	1	0	0	1

**Table 19. LDO1 Control Register (DEFLDO1) Field Descriptions**

Bit	Field	Type	Reset	Description
D7-D4	Reserved	R/W	0	
D3-D0	LDO1[3:0]	R/W	1001	LDO1 output voltage setting 0000 – 1.00 V 0001 – 1.10 V 0010 – 1.20 V 0011 – 1.25 V 0100 – 1.30 V 0101 – 1.35 V 0110 – 1.40 V 0111 – 1.50 V 1000 – 1.60 V 1001 – 1.80 V 1010 – 2.50 V 1011 – 2.75 V 1100 – 2.80 V 1101 – 3.00 V 1110 – 3.10 V 1111 – 3.30 V

**9.6.21 LDO2 Control Register (DEFLDO2)**
**Figure 44. LDO2 Control Register (DEFLDO2)  
Address – 0x13h (Password Protected)**

DATA BIT	D7	D6	D5	D4	D3	D2	D1	D0
FIELD NAME	not used	TRACK	LDO2[5:0]					
READ/WRITE	R/W	R/W	R/W	R/W	R/W	R/W	R/W	R/W
RESET VALUE	0	0	1	1	1	0	0	0

**Table 20. LDO2 Control Register (DEFLDO2) Field Descriptions**

Bit	Field	Type	Reset	Description																																																																
D7	Reserved	R/W	0																																																																	
D6	TRACK	R/W	0	LDO2 tracking bit 0 – Output voltage is defined by LDO2[5:0] bits 1 – Output voltage follows DCDC3 voltage setting (DEFDCDC3 register)																																																																
D5-D0	LDO2[5:0]	R/W	1110	LDO2 output voltage setting <table border="0" style="width: 100%; border-collapse: collapse;"> <tr> <td style="width: 25%;">00 0000 – 0.900 V</td> <td style="width: 25%;">01 0000 – 1.300 V</td> <td style="width: 25%;">10 0000 – 1.900 V</td> <td style="width: 25%;">11 0000 – 2.700 V</td> </tr> <tr> <td>00 0001 – 0.925 V</td> <td>01 0001 – 1.325 V</td> <td>10 0001 – 1.950 V</td> <td>11 0001 – 2.750 V</td> </tr> <tr> <td>00 0010 – 0.950 V</td> <td>01 0010 – 1.350 V</td> <td>10 0010 – 2.000 V</td> <td>11 0010 – 2.800 V</td> </tr> <tr> <td>00 0011 – 0.975 V</td> <td>01 0011 – 1.375 V</td> <td>10 0011 – 2.050 V</td> <td>11 0011 – 2.850 V</td> </tr> <tr> <td>00 0100 – 1.000 V</td> <td>01 0100 – 1.400 V</td> <td>10 0100 – 2.100 V</td> <td>11 0100 – 2.900 V</td> </tr> <tr> <td>00 0101 – 1.025 V</td> <td>01 0101 – 1.425 V</td> <td>10 0101 – 2.150 V</td> <td>11 0101 – 3.000 V</td> </tr> <tr> <td>00 0110 – 1.050 V</td> <td>01 0110 – 1.450 V</td> <td>10 0110 – 2.200 V</td> <td>11 0110 – 3.100 V</td> </tr> <tr> <td>00 0111 – 1.075 V</td> <td>01 0111 – 1.475 V</td> <td>10 0111 – 2.250 V</td> <td>11 0111 – 3.200 V</td> </tr> <tr> <td>00 1000 – 1.100 V</td> <td>01 1000 – 1.500 V</td> <td>10 1000 – 2.300 V</td> <td>11 1000 – 3.300 V</td> </tr> <tr> <td>00 1001 – 1.125 V</td> <td>01 1001 – 1.550 V</td> <td>10 1001 – 2.350 V</td> <td>11 1001 – 3.300 V</td> </tr> <tr> <td>00 1010 – 1.150 V</td> <td>01 1010 – 1.600 V</td> <td>10 1010 – 2.400 V</td> <td>11 1010 – 3.300 V</td> </tr> <tr> <td>00 1011 – 1.175 V</td> <td>01 1011 – 1.650 V</td> <td>10 1011 – 2.450 V</td> <td>11 1011 – 3.300 V</td> </tr> <tr> <td>00 1100 – 1.200 V</td> <td>01 1100 – 1.700 V</td> <td>10 1100 – 2.500 V</td> <td>11 1100 – 3.300 V</td> </tr> <tr> <td>00 1101 – 1.225 V</td> <td>01 1101 – 1.750 V</td> <td>10 1101 – 2.550 V</td> <td>11 1101 – 3.300 V</td> </tr> <tr> <td>00 1110 – 1.250 V</td> <td>01 1110 – 1.800 V</td> <td>10 1110 – 2.600 V</td> <td>11 1110 – 3.300 V</td> </tr> <tr> <td>00 1111 – 1.275 V</td> <td>01 1111 – 1.850 V</td> <td>10 1111 – 2.650 V</td> <td>11 1111 – 3.300 V</td> </tr> </table>	00 0000 – 0.900 V	01 0000 – 1.300 V	10 0000 – 1.900 V	11 0000 – 2.700 V	00 0001 – 0.925 V	01 0001 – 1.325 V	10 0001 – 1.950 V	11 0001 – 2.750 V	00 0010 – 0.950 V	01 0010 – 1.350 V	10 0010 – 2.000 V	11 0010 – 2.800 V	00 0011 – 0.975 V	01 0011 – 1.375 V	10 0011 – 2.050 V	11 0011 – 2.850 V	00 0100 – 1.000 V	01 0100 – 1.400 V	10 0100 – 2.100 V	11 0100 – 2.900 V	00 0101 – 1.025 V	01 0101 – 1.425 V	10 0101 – 2.150 V	11 0101 – 3.000 V	00 0110 – 1.050 V	01 0110 – 1.450 V	10 0110 – 2.200 V	11 0110 – 3.100 V	00 0111 – 1.075 V	01 0111 – 1.475 V	10 0111 – 2.250 V	11 0111 – 3.200 V	00 1000 – 1.100 V	01 1000 – 1.500 V	10 1000 – 2.300 V	11 1000 – 3.300 V	00 1001 – 1.125 V	01 1001 – 1.550 V	10 1001 – 2.350 V	11 1001 – 3.300 V	00 1010 – 1.150 V	01 1010 – 1.600 V	10 1010 – 2.400 V	11 1010 – 3.300 V	00 1011 – 1.175 V	01 1011 – 1.650 V	10 1011 – 2.450 V	11 1011 – 3.300 V	00 1100 – 1.200 V	01 1100 – 1.700 V	10 1100 – 2.500 V	11 1100 – 3.300 V	00 1101 – 1.225 V	01 1101 – 1.750 V	10 1101 – 2.550 V	11 1101 – 3.300 V	00 1110 – 1.250 V	01 1110 – 1.800 V	10 1110 – 2.600 V	11 1110 – 3.300 V	00 1111 – 1.275 V	01 1111 – 1.850 V	10 1111 – 2.650 V	11 1111 – 3.300 V
00 0000 – 0.900 V	01 0000 – 1.300 V	10 0000 – 1.900 V	11 0000 – 2.700 V																																																																	
00 0001 – 0.925 V	01 0001 – 1.325 V	10 0001 – 1.950 V	11 0001 – 2.750 V																																																																	
00 0010 – 0.950 V	01 0010 – 1.350 V	10 0010 – 2.000 V	11 0010 – 2.800 V																																																																	
00 0011 – 0.975 V	01 0011 – 1.375 V	10 0011 – 2.050 V	11 0011 – 2.850 V																																																																	
00 0100 – 1.000 V	01 0100 – 1.400 V	10 0100 – 2.100 V	11 0100 – 2.900 V																																																																	
00 0101 – 1.025 V	01 0101 – 1.425 V	10 0101 – 2.150 V	11 0101 – 3.000 V																																																																	
00 0110 – 1.050 V	01 0110 – 1.450 V	10 0110 – 2.200 V	11 0110 – 3.100 V																																																																	
00 0111 – 1.075 V	01 0111 – 1.475 V	10 0111 – 2.250 V	11 0111 – 3.200 V																																																																	
00 1000 – 1.100 V	01 1000 – 1.500 V	10 1000 – 2.300 V	11 1000 – 3.300 V																																																																	
00 1001 – 1.125 V	01 1001 – 1.550 V	10 1001 – 2.350 V	11 1001 – 3.300 V																																																																	
00 1010 – 1.150 V	01 1010 – 1.600 V	10 1010 – 2.400 V	11 1010 – 3.300 V																																																																	
00 1011 – 1.175 V	01 1011 – 1.650 V	10 1011 – 2.450 V	11 1011 – 3.300 V																																																																	
00 1100 – 1.200 V	01 1100 – 1.700 V	10 1100 – 2.500 V	11 1100 – 3.300 V																																																																	
00 1101 – 1.225 V	01 1101 – 1.750 V	10 1101 – 2.550 V	11 1101 – 3.300 V																																																																	
00 1110 – 1.250 V	01 1110 – 1.800 V	10 1110 – 2.600 V	11 1110 – 3.300 V																																																																	
00 1111 – 1.275 V	01 1111 – 1.850 V	10 1111 – 2.650 V	11 1111 – 3.300 V																																																																	

**9.6.22 Load Switch1 / LDO3 Control Register (DEFLS1)**
**Figure 45. Load Switch1 / LDO3 Control Register (DEFLS1)  
Address – 0x14h (Password Protected)**

DATA BIT		D7	D6	D5	D4	D3	D2	D1	D0
FIELD NAME		not used	not used	LS1LDO3	LDO3[4:0]				
READ/WRITE		R/W	R/W	R/W	R/W	R/W	R/W	R/W	R/W
RESET VALUE	TPS65217A	0	0	0	0	0	1	1	0
	TPS65217B	0	0	1	1	1	1	1	1
	TPS65217C	0	0	1	0	0	1	1	0
	TPS65217D	0	0	1	0	0	1	1	0

**Table 21. Load Switch1 / LDO3 Control Register Field Descriptions**

Bit	Field	Type	Reset	Description																																
D7-D6	Reserved	R/W	0																																	
D5	LS1LDO3	R/W	TPS65217A: 0 TPS65217B: 1 TPS65217C: 1 TPS65217D: 1	LS / LDO tracking bit 0 – FET functions as load switch (LS1) 1 – FET is configured as LDO3																																
D5-D0	LDO3[5:0]	R/W	1110	LDO3 output voltage setting  <table border="0" style="width: 100%; border-collapse: collapse;"> <tr> <td style="width: 50%;">0 0000 – 1.50 V</td> <td style="width: 50%;">01 0000 – 2.55 V</td> </tr> <tr> <td>0 0001 – 1.55 V</td> <td>01 0001 – 2.60 V</td> </tr> <tr> <td>0 0010 – 1.60 V</td> <td>01 0010 – 2.65 V</td> </tr> <tr> <td>0 0011 – 1.65 V</td> <td>01 0011 – 2.70 V</td> </tr> <tr> <td>0 0100 – 1.70 V</td> <td>01 0100 – 2.75 V</td> </tr> <tr> <td>0 0101 – 1.75 V</td> <td>01 0101 – 2.80 V</td> </tr> <tr> <td>0 0110 – 1.80 V</td> <td>01 0110 – 2.85 V</td> </tr> <tr> <td>0 0111 – 1.85 V</td> <td>01 0111 – 2.90 V</td> </tr> <tr> <td>0 1000 – 1.90 V</td> <td>01 1000 – 2.95 V</td> </tr> <tr> <td>0 1001 – 2.00 V</td> <td>01 1001 – 3.00 V</td> </tr> <tr> <td>0 1010 – 2.10 V</td> <td>01 1010 – 3.05 V</td> </tr> <tr> <td>0 1011 – 2.20 V</td> <td>01 1011 – 3.10 V</td> </tr> <tr> <td>0 1100 – 2.30 V</td> <td>01 1100 – 3.15 V</td> </tr> <tr> <td>0 1101 – 2.40 V</td> <td>01 1101 – 3.20 V</td> </tr> <tr> <td>0 1110 – 2.45 V</td> <td>01 1110 – 3.25 V</td> </tr> <tr> <td>0 1111 – 2.50 V</td> <td>01 1111 – 3.30 V</td> </tr> </table>	0 0000 – 1.50 V	01 0000 – 2.55 V	0 0001 – 1.55 V	01 0001 – 2.60 V	0 0010 – 1.60 V	01 0010 – 2.65 V	0 0011 – 1.65 V	01 0011 – 2.70 V	0 0100 – 1.70 V	01 0100 – 2.75 V	0 0101 – 1.75 V	01 0101 – 2.80 V	0 0110 – 1.80 V	01 0110 – 2.85 V	0 0111 – 1.85 V	01 0111 – 2.90 V	0 1000 – 1.90 V	01 1000 – 2.95 V	0 1001 – 2.00 V	01 1001 – 3.00 V	0 1010 – 2.10 V	01 1010 – 3.05 V	0 1011 – 2.20 V	01 1011 – 3.10 V	0 1100 – 2.30 V	01 1100 – 3.15 V	0 1101 – 2.40 V	01 1101 – 3.20 V	0 1110 – 2.45 V	01 1110 – 3.25 V	0 1111 – 2.50 V	01 1111 – 3.30 V
0 0000 – 1.50 V	01 0000 – 2.55 V																																			
0 0001 – 1.55 V	01 0001 – 2.60 V																																			
0 0010 – 1.60 V	01 0010 – 2.65 V																																			
0 0011 – 1.65 V	01 0011 – 2.70 V																																			
0 0100 – 1.70 V	01 0100 – 2.75 V																																			
0 0101 – 1.75 V	01 0101 – 2.80 V																																			
0 0110 – 1.80 V	01 0110 – 2.85 V																																			
0 0111 – 1.85 V	01 0111 – 2.90 V																																			
0 1000 – 1.90 V	01 1000 – 2.95 V																																			
0 1001 – 2.00 V	01 1001 – 3.00 V																																			
0 1010 – 2.10 V	01 1010 – 3.05 V																																			
0 1011 – 2.20 V	01 1011 – 3.10 V																																			
0 1100 – 2.30 V	01 1100 – 3.15 V																																			
0 1101 – 2.40 V	01 1101 – 3.20 V																																			
0 1110 – 2.45 V	01 1110 – 3.25 V																																			
0 1111 – 2.50 V	01 1111 – 3.30 V																																			

**9.6.23 Load Switch2 / LDO4 Control Register (DEFLS2)**
**Figure 46. Load Switch2 / LDO4 Control Register (DEFLS2)  
Address – 0x15h (Password Protected)**

DATA BIT		D7	D6	D5	D4	D3	D2	D1	D0
FIELD NAME		not used	not used	LS2LDO4	LDO4[4:0]				
READ/WRITE		R/W	R/W	R/W	R/W	R/W	R/W	R/W	R/W
RESET VALUE	TPS65217A	0	0	0	1	0	1	0	1
	TPS65217B	0	0	1	1	1	1	1	1
	TPS65217C	0	0	1	1	1	1	1	1
	TPS65217D	0	0	1	1	1	1	1	1

**Table 22. Load Switch2 / LDO4 Control Register (DEFLS2) Field Descriptions**

Bit	Field	Type	Reset	Description																																
D7-D6	Reserved	R/W	0																																	
D5	LS1LDO4	R/W	TPS65217A: 0 TPS65217B: 1 TPS65217C: 1 TPS65217D: 1	LS / LDO configuration bit 0 – FET functions as load switch (LS2) 1 – FET is configured as LDO4																																
D5-D0	LDO4[5:0]	R/W	TPS65217A: 1010 TPS65217B: 1111 TPS65217C: 1111 TPS65217D: 1111	LDO4 output voltage setting (LS2LDO4 = 1)  <table style="width: 100%; border: none;"> <tr> <td style="width: 50%;">0 0000 – 1.50 V</td> <td style="width: 50%;">01 0000 – 2.55 V</td> </tr> <tr> <td>0 0001 – 1.55 V</td> <td>01 0001 – 2.60 V</td> </tr> <tr> <td>0 0010 – 1.60 V</td> <td>01 0010 – 2.65 V</td> </tr> <tr> <td>0 0011 – 1.65 V</td> <td>01 0011 – 2.70 V</td> </tr> <tr> <td>0 0100 – 1.70 V</td> <td>01 0100 – 2.75 V</td> </tr> <tr> <td>0 0101 – 1.75 V</td> <td>01 0101 – 2.80 V</td> </tr> <tr> <td>0 0110 – 1.80 V</td> <td>01 0110 – 2.85 V</td> </tr> <tr> <td>0 0111 – 1.85 V</td> <td>01 0111 – 2.90 V</td> </tr> <tr> <td>0 1000 – 1.90 V</td> <td>01 1000 – 2.95 V</td> </tr> <tr> <td>0 1001 – 2.00 V</td> <td>01 1001 – 3.00 V</td> </tr> <tr> <td>0 1010 – 2.10 V</td> <td>01 1010 – 3.05 V</td> </tr> <tr> <td>0 1011 – 2.20 V</td> <td>01 1011 – 3.10 V</td> </tr> <tr> <td>0 1100 – 2.30 V</td> <td>01 1100 – 3.15 V</td> </tr> <tr> <td>0 1101 – 2.40 V</td> <td>01 1101 – 3.20 V</td> </tr> <tr> <td>0 1110 – 2.45 V</td> <td>01 1110 – 3.25 V</td> </tr> <tr> <td>0 1111 – 2.50 V</td> <td>01 1111 – 3.30 V</td> </tr> </table>	0 0000 – 1.50 V	01 0000 – 2.55 V	0 0001 – 1.55 V	01 0001 – 2.60 V	0 0010 – 1.60 V	01 0010 – 2.65 V	0 0011 – 1.65 V	01 0011 – 2.70 V	0 0100 – 1.70 V	01 0100 – 2.75 V	0 0101 – 1.75 V	01 0101 – 2.80 V	0 0110 – 1.80 V	01 0110 – 2.85 V	0 0111 – 1.85 V	01 0111 – 2.90 V	0 1000 – 1.90 V	01 1000 – 2.95 V	0 1001 – 2.00 V	01 1001 – 3.00 V	0 1010 – 2.10 V	01 1010 – 3.05 V	0 1011 – 2.20 V	01 1011 – 3.10 V	0 1100 – 2.30 V	01 1100 – 3.15 V	0 1101 – 2.40 V	01 1101 – 3.20 V	0 1110 – 2.45 V	01 1110 – 3.25 V	0 1111 – 2.50 V	01 1111 – 3.30 V
0 0000 – 1.50 V	01 0000 – 2.55 V																																			
0 0001 – 1.55 V	01 0001 – 2.60 V																																			
0 0010 – 1.60 V	01 0010 – 2.65 V																																			
0 0011 – 1.65 V	01 0011 – 2.70 V																																			
0 0100 – 1.70 V	01 0100 – 2.75 V																																			
0 0101 – 1.75 V	01 0101 – 2.80 V																																			
0 0110 – 1.80 V	01 0110 – 2.85 V																																			
0 0111 – 1.85 V	01 0111 – 2.90 V																																			
0 1000 – 1.90 V	01 1000 – 2.95 V																																			
0 1001 – 2.00 V	01 1001 – 3.00 V																																			
0 1010 – 2.10 V	01 1010 – 3.05 V																																			
0 1011 – 2.20 V	01 1011 – 3.10 V																																			
0 1100 – 2.30 V	01 1100 – 3.15 V																																			
0 1101 – 2.40 V	01 1101 – 3.20 V																																			
0 1110 – 2.45 V	01 1110 – 3.25 V																																			
0 1111 – 2.50 V	01 1111 – 3.30 V																																			

**9.6.24 Enable Register (ENABLE)**
**Figure 47. Enable Register (ENABLE)  
Address – 0x16h (Password Protected)**

DATA BIT	D7	D6	D5	D4	D3	D2	D1	D0
FIELD NAME	not used	LS1_EN	LS2_EN	DC1_EN	DC2_EN	DC3_EN	LDO1_EN	LDO2_EN
READ/WRITE	R/W	R/W	R/W	R/W	R/W	R/W	R/W	R/W
RESET VALUE	0	0	0	0	0	0	0	0

**Table 23. Enable Register (ENABLE) Field Descriptions**

Bit	Field	Type	Reset	Description
D7	Reserved	R/W	0	
D6	LS1_EN	R/W	0	Load Switch1/LDO3 enable bit 0 – disabled 1 – enabled NOTE: PWR_EN pin must be high to enable LS1/LDO3
D5	LS2_EN	R/W	0	Load Switch2/LDO4 enable bit 0 – disabled 1 – enabled NOTE: PWR_EN pin must be high to enable LS2/LDO4
D4	DC1_EN	R/W	0	DCDC1 enable bit 0 – DCDC1 is disabled 1 – DCDC1 is enabled NOTE: PWR_EN pin must be high to enable DCDC
D3	DC2_EN	R/W	0	DCDC2 enable bit 0 – DCDC2 is disabled 1 – DCDC2 is enabled NOTE: PWR_EN pin must be high to enable DCDC
D2	DC3_EN	R/W	0	DCDC3 enable bit 0 – DCDC3 is disabled 1 – DCDC3 is enabled NOTE: PWR_EN pin must be high to enable DCDC
D1	LDO1_EN	R/W	0	LDO1 enable bit 0 – disabled 1 – enabled
D0	LDO2_EN	R/W	0	LDO2 enable bit 0 – disabled 1 – enabled



**9.6.25 UVLO Control Register (DEFUVLO)**
**Figure 48. UVLO Control Register (DEFUVLO)  
Address – 0x18h (Password Protected)**

DATA BIT	D7	D6	D5	D4	D3	D2	D1	D0
FIELD NAME	not used	not used	not used	not used	not used	not used	UVLO[1:0]	
READ/WRITE	R/W	R/W	R/W	R/W	R/W	R/W	R/W	R/W
RESET VALUE	0	0	0	0	0	0	1	1

**Table 24. UVLO Control Register (DEFUVLO) Field Descriptions**

Bit	Field	Type	Reset	Description
D7-D2	Reserved	R/W	0	
D1-D0	UVLO[1:0]	R/W	0011	Under Voltage Lock Out setting 00 – 2.73 V 01 – 2.89 V 10 – 3.18 V 11 – 3.30 V

**9.6.26 Sequencer Register 1 (SEQ1)**
**Figure 49. Sequencer Register 1 (SEQ1)  
Address – 0x19h (Password Protected)**

DATA BIT		D7	D6	D5	D4	D3	D2	D1	D0
FIELD NAME		DC1_SEQ[3:0]				DC2_SEQ[3:0]			
READ/WRITE		R	R/W	R/W	R/W	R	R/W	R/W	R/W
RESET VALUE	TPS65217A	0	0	0	1	0	0	1	0
	TPS65217B	0	0	0	1	0	1	0	1
	TPS65217C	0	0	0	1	0	1	0	1
	TPS65217D	0	0	0	1	0	1	0	1

**Table 25. Sequencer Register 1 (SEQ1) Field Descriptions**

Bit	Field	Type	Reset	Description
D7-D4	DC1_SEQ[3:0]	R/W	TPS65217A: 0001 TPS65217B: 0001 TPS65217C: 0001 TPS65217D: 0001	DCDC1 enable STROBE 0000 – rail is not controlled by sequencer 0001 – enable at STROBE1 0010 – enable at STROBE2 0011 – enable at STROBE3 0100 – enable at STROBE4 0101 – enable at STROBE5 0110 – enable at STROBE6 0111 – enable at STROBE7
D3-D0	DC2_SEQ[3:0]	R/W	TPS65217A: 0010 TPS65217B: 0101 TPS65217C: 0101 TPS65217D: 0101	DCDC2 enable STROBE 0000 – rail is not controlled by sequencer 0001 – enable at STROBE1 0010 – enable at STROBE2 0011 – enable at STROBE3 0100 – enable at STROBE4 0101 – enable at STROBE5 0110 – enable at STROBE6 0111 – enable at STROBE7

**9.6.27 Sequencer Register 2 (SEQ2)**
**Figure 50. Sequencer Register 2 (SEQ2)  
Address – 0x1Ah (Password Protected)**

DATA BIT		D7	D6	D5	D4	D3	D2	D1	D0
FIELD NAME		DC3_SEQ[3:0]				LDO1_SEQ[3:0]			
READ/WRITE		R	R/W	R/W	R/W	R/W	R/W	R/W	R/W
RESET VALUE	TPS65217A	0	0	1	1	1	0	1	1
	TPS65217B	0	1	0	1	1	1	1	1
	TPS65217C	0	1	0	1	1	1	1	1
	TPS65217D	0	1	0	1	1	1	1	1

**Table 26. Sequencer Register 2 (SEQ2) Field Descriptions**

Bit	Field	Type	Reset	Description
D7-D4	DC3_SEQ[3:0]	R/W	TPS65217A: 0011 TPS65217B: 0101 TPS65217C: 0101 TPS65217D: 0101	DCDC3 enable STROBE 0000 – rail is not controlled by sequencer 0001 – enable at STROBE1 0010 – enable at STROBE2 0011 – enable at STROBE3 0100 – enable at STROBE4 0101 – enable at STROBE5 0110 – enable at STROBE6 0111 – enable at STROBE7
D3-D0	LDO1_SEQ[3:0]	R/W	TPS65217A: 1011 TPS65217B: 1111 TPS65217C: 1111 TPS65217D: 1111	LDO1 enable state 0000 – rail is not controlled by sequencer 0001 – enable at STROBE1 0010 – enable at STROBE2 0011 – enable at STROBE3 0100 – enable at STROBE4 0101 – enable at STROBE5 0110 – enable at STROBE6 0111 – enable at STROBE7 1000 – rail is not controlled by sequencer 1001 – rail is not controlled by sequencer ... 1110 – enable at STROBE14 1111 – enabled at STROBE15 (with SYS)

**9.6.28 Sequencer Register 3 (SEQ3)**
**Figure 51. Sequencer Register 3 (SEQ3)  
Address – 0x1Bh (Password Protected)**

DATA BIT		D7	D6	D5	D4	D3	D2	D1	D0
FIELD NAME		LDO2_SEQ[3:0]				LDO3_SEQ[3:0]			
READ/WRITE		R/WR	R/W	R/W	R/W	R	R/W	R/W	R/W
RESET VALUE	TPS65217A	0	0	1	0	0	0	0	1
	TPS65217B	0	0	1	0	0	0	1	1
	TPS65217C	0	0	1	1	0	0	1	0
	TPS65217D	0	0	1	1	0	0	1	0

**Table 27. Sequencer Register 3 (SEQ3) Field Descriptions**

Bit	Field	Type	Reset	Description
D7-D4	LDO2_SEQ[3:0]	R/W	TPS65217A: 0010 TPS65217B: 0010 TPS65217C: 0011 TPS65217D: 0011	LDO2 enable STROBE 0000 – rail is not controlled by sequencer 0001 – enable at STROBE1 0010 – enable at STROBE2 0011 – enable at STROBE3 0100 – enable at STROBE4 0101 – enable at STROBE5 0110 – enable at STROBE6 0111 – enable at STROBE7 1000 – rail is not controlled by sequencer 1001 – rail is not controlled by sequencer ... 1110 – enable at STROBE14 1111 – enabled at STROBE15 (with SYS)
D3-D0	LDO3_SEQ[3:0]	R/W	TPS65217A: 0001 TPS65217B: 0011 TPS65217C: 0010 TPS65217D: 0010	LS1/LDO3 enable state 0000 – rail is not controlled by sequencer 0001 – enable at STROBE1 0010 – enable at STROBE2 0011 – enable at STROBE3 0100 – enable at STROBE4 0101 – enable at STROBE5 0110 – enable at STROBE6 0111 – enable at STROBE7

**9.6.29 Sequencer Register 4 (SEQ4)**

**Figure 52. Sequencer Register 4 (SEQ4)  
Address – 0x1Ch (Password Protected)**

DATA BIT	D7	D6	D5	D4	D3	D2	D1	D0
FIELD NAME	LDO4_SEQ[3:0]				not used	not used	not used	not used
READ/WRITE	R	R/W	R/W	R/W	R/W	R/W	R/W	R/W
RESET VALUE	0	1	0	0	0	0	0	0

**Table 28. Sequencer Register 4 (SEQ4) Field Descriptions**

Bit	Field	Type	Reset	Description
D7-D4	LDO4_SEQ[3:0]	R/W	0100	LS2/LDO4 enable state 0000 – rail is not controlled by sequencer 0001 – enable at STROBE1 0010 – enable at STROBE2 0011 – enable at STROBE3 0100 – enable at STROBE4 0101 – enable at STROBE5 0110 – enable at STROBE6 0111 – enable at STROBE7
D3-D0	Reserved	R/W	0	

**9.6.30 Sequencer Register 5 (SEQ5)**
**Figure 53. Sequencer Register 5 (SEQ5)  
Address – 0x1Dh (Password Protected)**

DATA BIT		D7	D6	D5	D4	D3	D2	D1	D0
FIELD NAME		DLY1[1:0]		DLY2[1:0]		DLY3[1:0]		DLY4[1:0]	
READ/WRITE		R/W	R/W	R/W	R/W	R/W	R/W	R/W	R/W
RESET VALUE	TPS65217A	1	0	0	0	0	0	0	0
	TPS65217B	1	0	0	0	0	0	0	0
	TPS65217C	0	0	1	0	0	0	0	0
	TPS65217D	0	0	1	0	0	0	0	0

**Table 29. Sequencer Register 5 (SEQ5) Field Descriptions**

Bit	Field	Type	Reset	Description
D7-D6	DLY1[1:0]	R/W	TPS65217A: 10 TPS65217B: 10 TPS65217C: 0 TPS65217D: 0	Delay1 time 00 – 1 ms 01 – 2 ms 10 – 5 ms 11 – 10 ms
D5-D4	DLY2[1:0]	R/W	TPS65217A: 0 TPS65217B: 0 TPS65217C: 10 TPS65217D: 10	Delay2 time 00 – 1 ms 01 – 2 ms 10 – 5 ms 11 – 10 ms
D3-D2	DLY3[1:0]	R/W	0	Delay3 time 00 – 1 ms 01 – 2 ms 10 – 5 ms 11 – 10 ms
D1-D0	DLY4[1:0]	R/W	0	Delay4 time 00 – 1 ms 01 – 2 ms 10 – 5 ms 11 – 10 ms

**9.6.31 Sequencer Register 6 (SEQ6)**
**Figure 54. Sequencer Register 6 (SEQ6)  
Address – 0x1Eh (Password Protected)**

DATA BIT	D7	D6	D5	D4	D3	D2	D1	D0
FIELD NAME	DLY5[1:0]		DLY6[1:0]		not used	SEQUP	SEQDWN	INSTDWN
READ/WRITE	R/W	R/W	R/W	R/W	R/W	R/W	R/W	R/W
RESET VALUE	0	0	0	0	0	0	0	0

**Table 30. Sequencer Register 6 (SEQ6) Field Descriptions**

Bit	Field	Type	Reset	Description
D7-D6	DLY5[1:0]	R/W	0	Delay5 time 00 – 1 ms 01 – 2 ms 10 – 5 ms 11 – 10 ms
D5-D4	DLY6[1:0]	R/W	0	Delay6 time 00 – 1 ms 01 – 2 ms 10 – 5 ms 11 – 10 ms
D3	Reserved	R/W	0	
D2	SEQUP	R/W	0	Set this bit to 1 to trigger a power-up sequence. Bit is automatically reset to 0.
D1	SEQDWN	R/W	0	Set this bit to 1 to trigger a power-down sequence. Bit is automatically reset to 0.
D0	INSTDWN	R/W	0	Instant shut-down bit 0 – shut-down follows reverse power-up sequence 1 – all delays are bypassed and all rails are shut-down simultaneously NOTE: Shut-down occurs when PWR_EN pin is pulled low or SEQDWN bit is set. Only those rails controlled by the sequencer will be shut down.

## 10 Application and Implementation

---

### NOTE

Information in the following applications sections is not part of the TI component specification, and TI does not warrant its accuracy or completeness. TI's customers are responsible for determining suitability of components for their purposes. Customers should validate and test their design implementation to confirm system functionality.

---

### 10.1 Application Information

The TPS65217 is designed to pair with various application processors. For detailed information on using TPS65217 with Sitara AM335x processors, see *Powering the AM335x with TPS65217* ([SLVU551](#)).



## 10.2 Typical Application

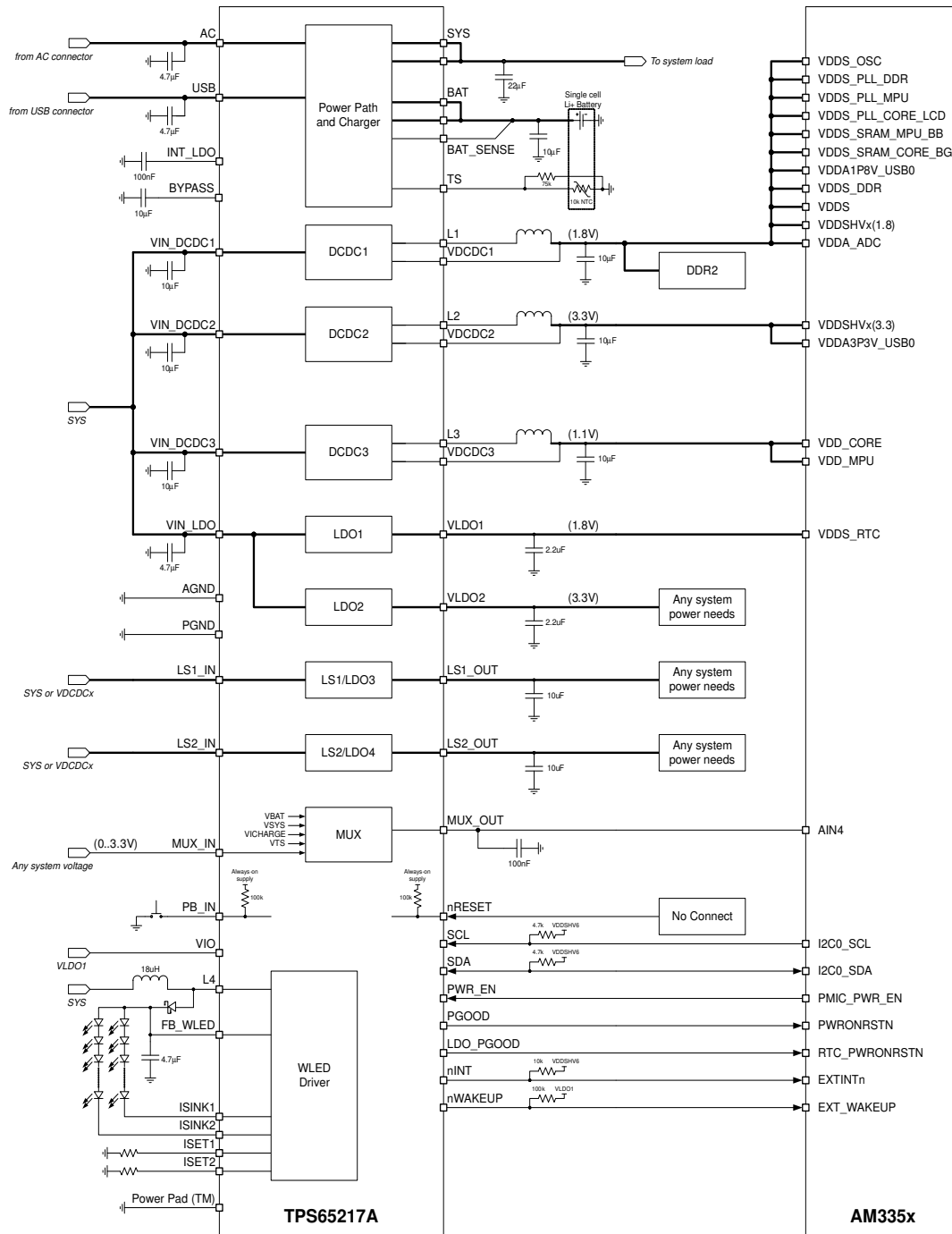

See [SLVU551](#) for connection diagrams for all of the TPS65217 family.

**Figure 55. Connection Diagram for Typical Application**

## Typical Application (continued)

### 10.2.1 Design Requirements

**Table 31. Design Requirements**

	VOLTAGE	SEQUENCE
DCDC1	1.8 V	1
DCDC2	3.3 V	2
DCDC3	1.1 V	3
LDO1	1.8 V	15
LDO2	3.3 V	2
LS1/LDO3	Load switch	1
LS2/LDO4	Load switch	4

### 10.2.2 Detailed Design Procedure

**Table 32. Recommended Inductors for WLED Boost Converter**

PART NUMBER	SUPPLIER	VALUE (μH)	R <sub>DS</sub> (mΩ) MAX	RATED CURRENT (A)	DIMENSIONS (mm x mm x mm)
CDRH74NP-180M	Sumida	18	73	1.31	7.5 x 7.5 x 4.5
P1167.183	Pulse	18	37	1.5	7.5 x 7.5 x 4.5

**Table 33. Recommended Output Capacitors for WLED Boost Converter**

PART NUMBER	SUPPLIER	VOLTAGE RATING (V)	VALUE (μF)	DIMENSIONS	DIELECTRIC
UMK316BJ475ML-T	Taiyo Yuden	50	4.7	1206	X5R

#### 10.2.2.1 Output Filter Design (Inductor and Output Capacitor)

##### 10.2.2.1.1 Inductor Selection for Buck Converters

The step-down converters operate typically with 2.2-μH output inductors. Larger or smaller inductor values can be used to optimize the performance of the device for specific operation conditions. The selected inductor has to be rated for its DC resistance and saturation current. The DC resistance of the inductance will influence directly the efficiency of the converter. Therefore an inductor with lowest DC resistance should be selected for highest efficiency.

The following formula can be used to calculate the maximum inductor current under static load conditions. The saturation current of the inductor should be rated higher than the maximum inductor current because during heavy load transient the inductor current will rise above the calculated value.

$$\Delta I_L = V_{out} \cdot \frac{1 - \frac{V_{out}}{V_{in}}}{L \cdot f} \quad (4)$$

$$I_{L,max} = I_{out,max} + \frac{\Delta I_L}{2}$$

where

- f = Switching frequency (2.25 MHz typical)
  - L = Inductor value
  - ΔI<sub>L</sub> = Peak to peak inductor ripple current
  - I<sub>L,max</sub> = Maximum inductor current
- (5)

The highest inductor current will occur at maximum V<sub>IN</sub>. Open core inductors have a soft saturation characteristic and can usually handle higher inductor currents versus a comparable shielded inductor.

A more conservative approach is to select the inductor current rating just for the maximum switch current of the corresponding converter. It must be considered that the core material from inductor to inductor differs and will have an impact on the efficiency, especially at high-switching frequencies. Also the resistance of the windings will greatly affect the converter efficiency at high load. See [Table 34](#) for recommended inductors.

**Table 34. Recommended Inductors for DCDC1, DCDC2, and DCDC3**

PART NUMBER	SUPPLIER	VALUE (μH)	R <sub>DS</sub> (mΩ) MAX	RATED CURRENT (A)	DIMENSIONS (mm)
LQM2HPN2R2MG0L	Murata	2.2	100	1.3	2 x 2.5 x 0.9
VLCF4018T-2R2N1R4-2	TDK	2.2	60	1.44	3.9 x 4.7 x 1.8

#### 10.2.2.1.2 Output Capacitor Selection

The advanced Fast Response voltage mode control scheme of the two converters allow the use of small ceramic capacitors with a typical value of 10 μF, without having large output voltage under and overshoots during heavy load transients. Ceramic capacitors having low ESR values result in lowest output voltage ripple and are therefore recommended.

If ceramic output capacitors are used, the capacitor RMS ripple current rating must always meet the application requirements. For completeness, the RMS ripple current is calculated as:

$$I_{RMS\text{Cout}} = V_{out} \cdot \frac{1 - \frac{V_{out}}{V_{in}}}{L \cdot f} \cdot \frac{1}{2 \cdot \sqrt{3}} \quad (6)$$

At nominal load current the inductive converters operate in PWM mode and the overall output voltage ripple is the sum of the voltage spike caused by the output capacitor ESR plus the voltage ripple caused by charging and discharging the output capacitor:

$$\Delta V_{out} = V_{out} \cdot \frac{1 - \frac{V_{out}}{V_{in}}}{L \cdot f} \cdot \left( \frac{1}{8 \cdot C_{out} \cdot f} + ESR \right)$$

where

- the highest output voltage ripple occurs at the highest input voltage  $V_{IN}$  (7)

At light load currents the converters operate in power save mode and the output voltage ripple is dependent on the output capacitor value. The output voltage ripple is set by the internal comparator delay and the external capacitor. The typical output voltage ripple is less than 1% of the nominal output voltage.

#### 10.2.2.1.3 Input Capacitor Selection

Because of the nature of the buck converter having a pulsating input current, a low ESR input capacitor is required for best input voltage filtering and minimizing the interference with other circuits caused by high input voltage spikes. The converters need a ceramic input capacitor of 10 μF. The input capacitor can be increased without any limit for better input voltage filtering. See [Table 35](#) for recommended ceramic capacitors.

**Table 35. Recommended Input Capacitors for DCDC1, DCDC2, and DCDC3**

PART NUMBER	SUPPLIER	VALUE (μF)	DIMENSIONS
C2012X5R0J226MT	TDK	22	0805
JMK212BJ226MG	Taiyo Yuden	22	0805
JMK212BJ106M	Taiyo Yuden	10	0805
C2012X5R0J106M	TDK	10	0805

#### 10.2.2.2 Battery-Less/5-V Operation

TPS65217 provides a linear charger for Li+ batteries but the IC can operate without a battery attached. There are three basic use-cases for battery-less operation:

- The system is designed for battery operation, but the battery is not inserted. The system can be powered by connecting an AC adaptor or USB supply.

2. A non-portable system running off a (regulated) 5-V supply, but the PMIC must provide protection against input over-voltage up to 20 V. Electrically, this is the same as the previous case where the IC is powered off an AC adaptor. The battery pins (BAT, BATSENSE, TS) are floating and power is provided through the AC pin. DC-DC converters, WLED driver, and LDOs connect to the over-voltage protected SYS pins. Load switches (or LDO3 and LDO4, depending on configuration) typically connect to one of the lower system rails but may also be connected to the SYS pin.
3. A non-portable system running of a regulated 5-V supply that does not require input-over-voltage protection. In this case, the 5-V power supply is connected through the BAT pins, and the DC-DC converter inputs, WLED driver, LDO1, and LDO2, are connected directly to the 5-V supply. A 10-kΩ resistor is connected from TS to ground to simulate the NTC of the battery. Load switches (or LDO3 and LDO4, depending on configuration) typically connect to one of the lower system rails, but may also be connected to the 5-V input supply directly. The main advantage of connecting the supply to the BAT pins is higher power efficiency because the internal power path is bypassed and power loss across the internal switches is avoided.

Figure 56 shows the connection of the input power supply to the IC for 5-V only operation with and without 20-V input over-voltage protection and Table 36 lists the functional differences between both setups.

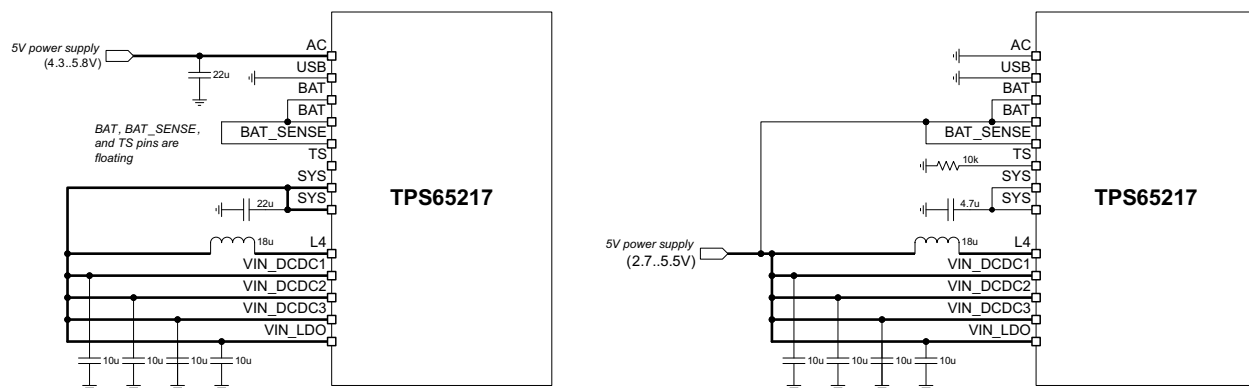

Left: Power-connection for battery-less/5-V only operation. The SYS node and DC-DC converters are protected against input overvoltage up to 20 V.

Right: Power-connection for 5-V only operation. The DC-DC converters are not protected against input overvoltage, but power efficiency is higher because the internal power path switches are bypassed.

**Figure 56. Power-Connection for Battery-Less/5-V Only Operation and Power-Connection for 5-V Only Operation**

**Table 36. Functional Differences Between Battery-Less/5-V Only Operation With and Without 20-V Input Over-Voltage Protection**

	POWER SUPPLIED THROUGH AC PIN (CASE (1) AND (2))	POWER SUPPLIED THROUGH BAT PIN (CASE (3))
Input protection	Max operating input voltage is 5.8 V, but IC is protected against input over-voltage up to 20 V.	Max operating input voltage is 5.5 V.
Power efficiency	DCDC input current passes through AC-SYS power-path switch (approximately 150 mΩ).	Internal power-path is bypassed to minimize IxR losses.
BATTEMP bit	BATTEMP bit (bit 0 in register 0x03h) always reads 1, but has no effect on operation of the part.	BATTEMP bit (bit 0 in register 0x03h) always reads 0.
Output rail status upon initial power connection	LDO1 is automatically powered up when AC pin is connected to 5-V supply and device enters [WAIT PWR_EN] state. IF PWR_EN pin is not asserted within 5s, LDO1 turns OFF.	LDO1 is OFF when BAT is connected to 5-V supply. PB_IN must be pulled low to enter [WAIT PWR_EN] state.
Response to input overvoltage	Device enters OFF mode. NOTE: If a battery is present in the system, TPS65217 automatically switches from AC to BAT supply when AC input exceeds 6.5 V and back to AC when AC input recovers to safe operating voltage range.	N/A.

### 10.2.3 Application Curves

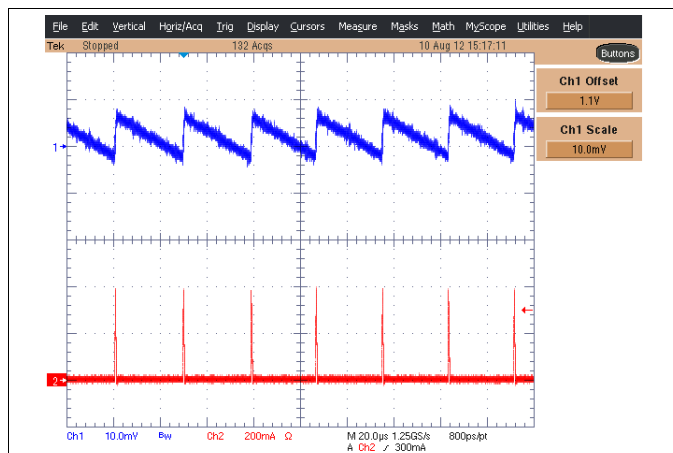

Figure 57. DCDC Inductor Current at 5 mA, 1.1-V Voltage Ripple

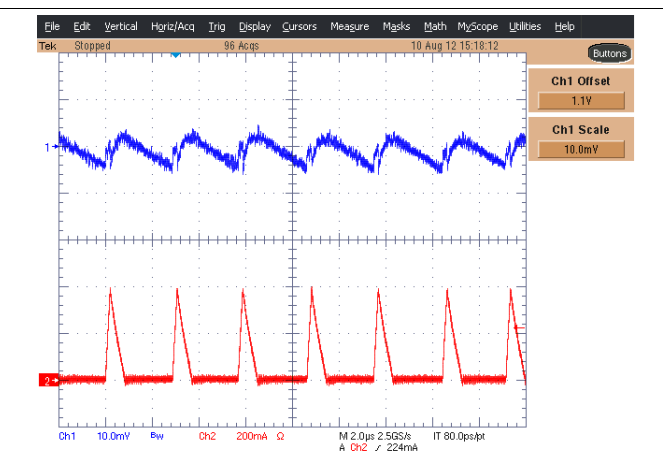

Figure 58. DCDC Inductor Current at 50 mA, 1.1-V Voltage Ripple

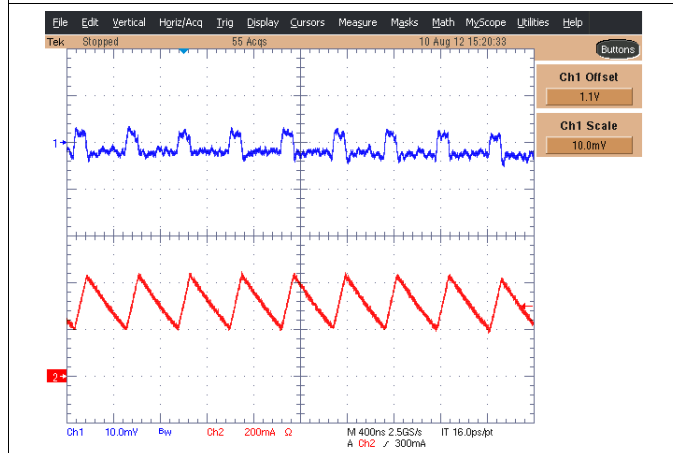

Figure 59. DCDC Inductor Current at 300 mA, 1.1-V Voltage Ripple

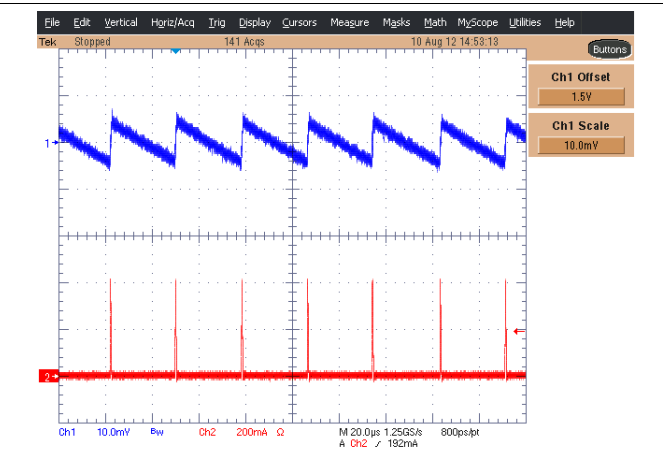

Figure 60. DCDC Inductor Current at 5 mA, 1.5-V Voltage Ripple

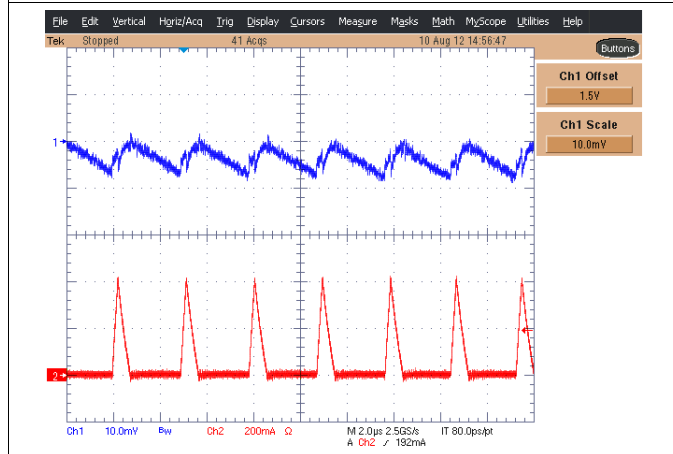

Figure 61. DCDC Inductor Current at 50 mA, 1.5-V Voltage Ripple

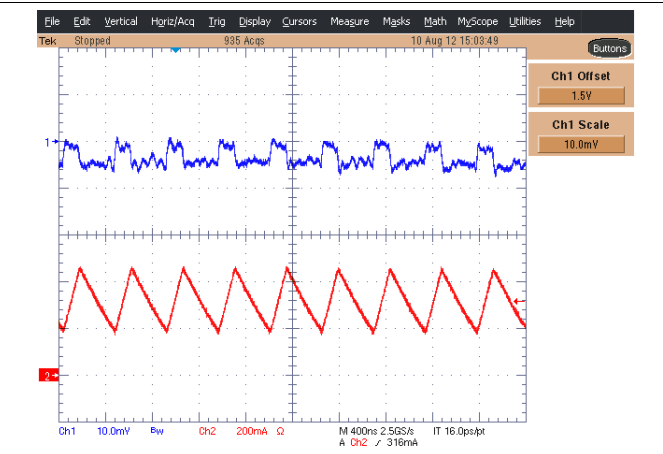
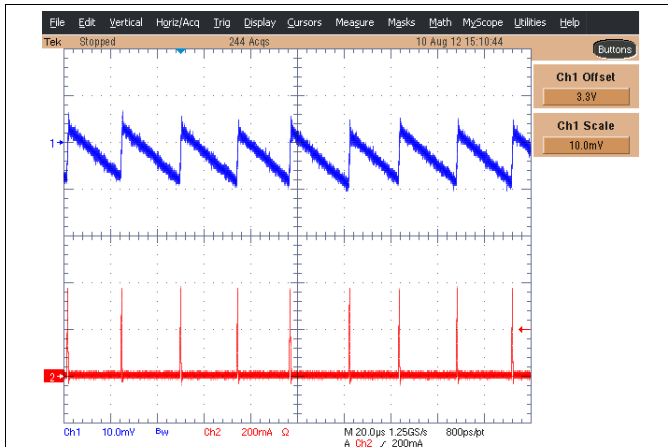
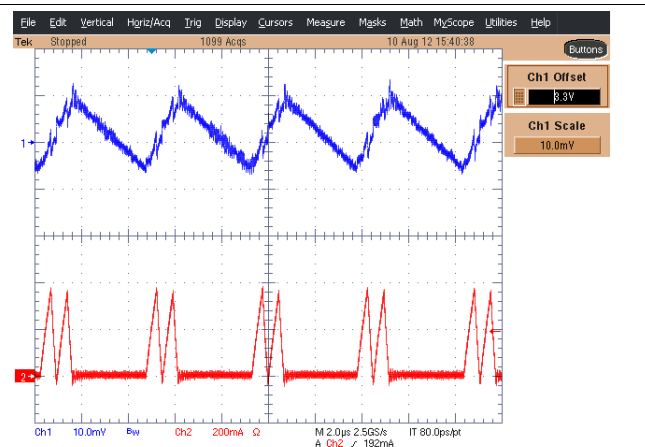

Figure 62. DCDC Inductor Current at 300 mA, 1.5-V Voltage Ripple



**Figure 63. DCDC Inductor Current at 5 mA, 3.3-V Voltage Ripple**



**Figure 64. DCDC Inductor Current at 50 mA, 3.3-V Voltage Ripple**

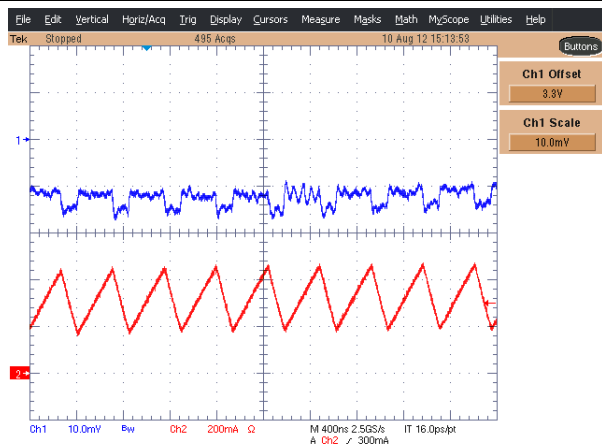

**Figure 65. DCDC Inductor Current at 300 mA, 3.3-V Voltage Ripple**

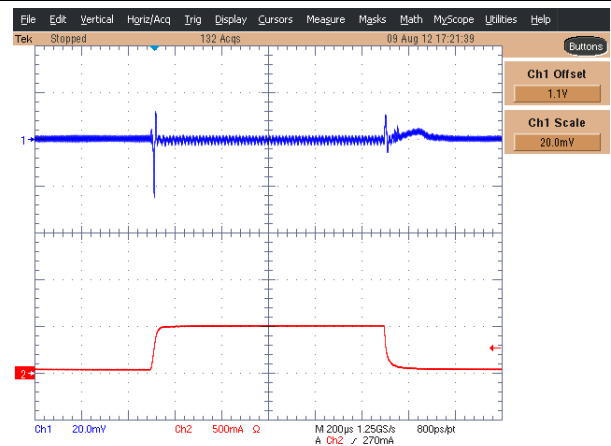

**Figure 66. DCDC Load Transient, 1.1 V Out, 50-500-50**

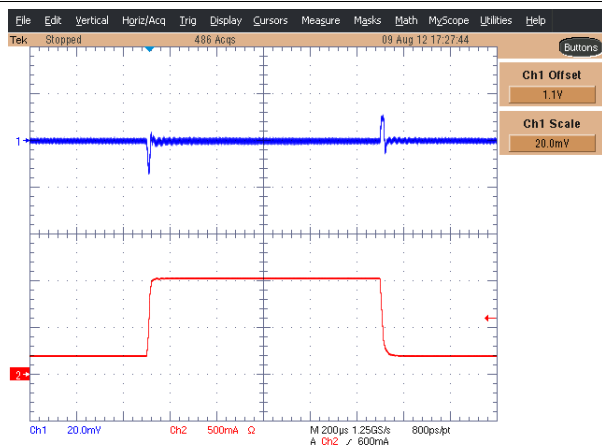

**Figure 67. DCDC Load Transient, 1.1 V Out, 200-1000-200**

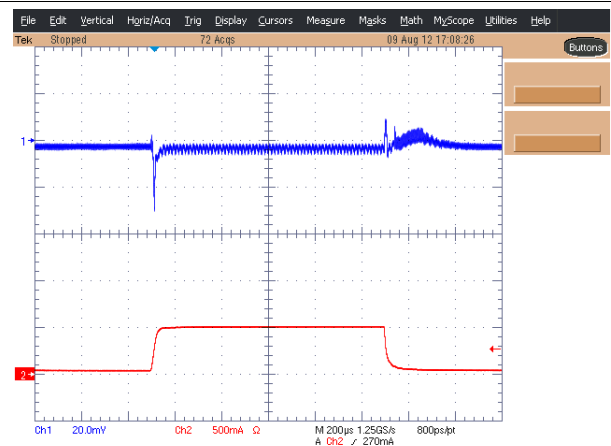

**Figure 68. DCDC Load Transient, 1.5 V Out, 50-500-50**

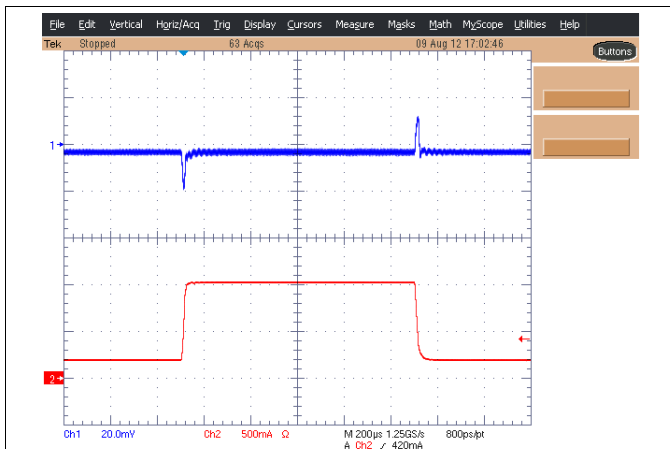

Figure 69. DCDC Load Transient, 1.5 V Out, 200-1000-200



Figure 70. DCDC Load Transient, 3.3 V Out, 50-500-50

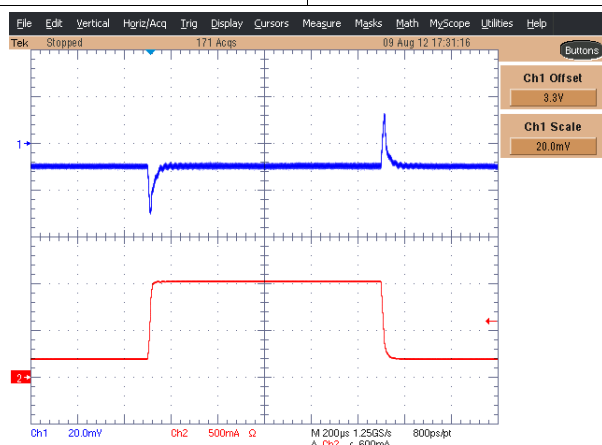

Figure 71. DCDC Load Transient, 3.3 V Out, 200-1000-200

## 11 Power Supply Recommendations

The device is designed to operate with an input voltage supply range between 2.75 V and 5.8 V. This input supply can be from a single-cell Li-ion, Li-Polymer batteries, DC supply, USB supply, or other externally regulated supply. If the input supply is located more than a few inches from the TPS65217, additional bulk capacitance may be required in addition to the ceramic bypass capacitors. An electrolytic capacitor with a value of 4.7  $\mu$ F is a typical choice.

## 12 Layout

### 12.1 Layout Guidelines

- The VIN\_DCDCx and VINLDO pins should be bypassed to ground with a low ESR ceramic bypass capacitor. The typical recommended bypass capacitance is 10  $\mu$ F and 4.7  $\mu$ F with a X5R or X7R dielectric respectively.
- The optimum placement is closest to the VIN\_DCDCx and VINLDO pins of the device. Care should be taken to minimize the loop area formed by the bypass capacitor connection, the VIN\_DCDCx and VINLDO pins, and the PowerPad of the device.
- The PowerPad should be tied to the PCB ground plane with multiple vias.
- The LX trace should be kept on the PCB top layer and free of any vias.
- The VLDOx and VDCDCx pins (feedback pins) traces should be routed away from any potential noise source to avoid coupling.
- DCDCx output capacitance should be placed immediately at the DCDCx pin. Excessive distance between the capacitance and DCDCx pin may cause poor converter performance.

### 12.2 Layout Example

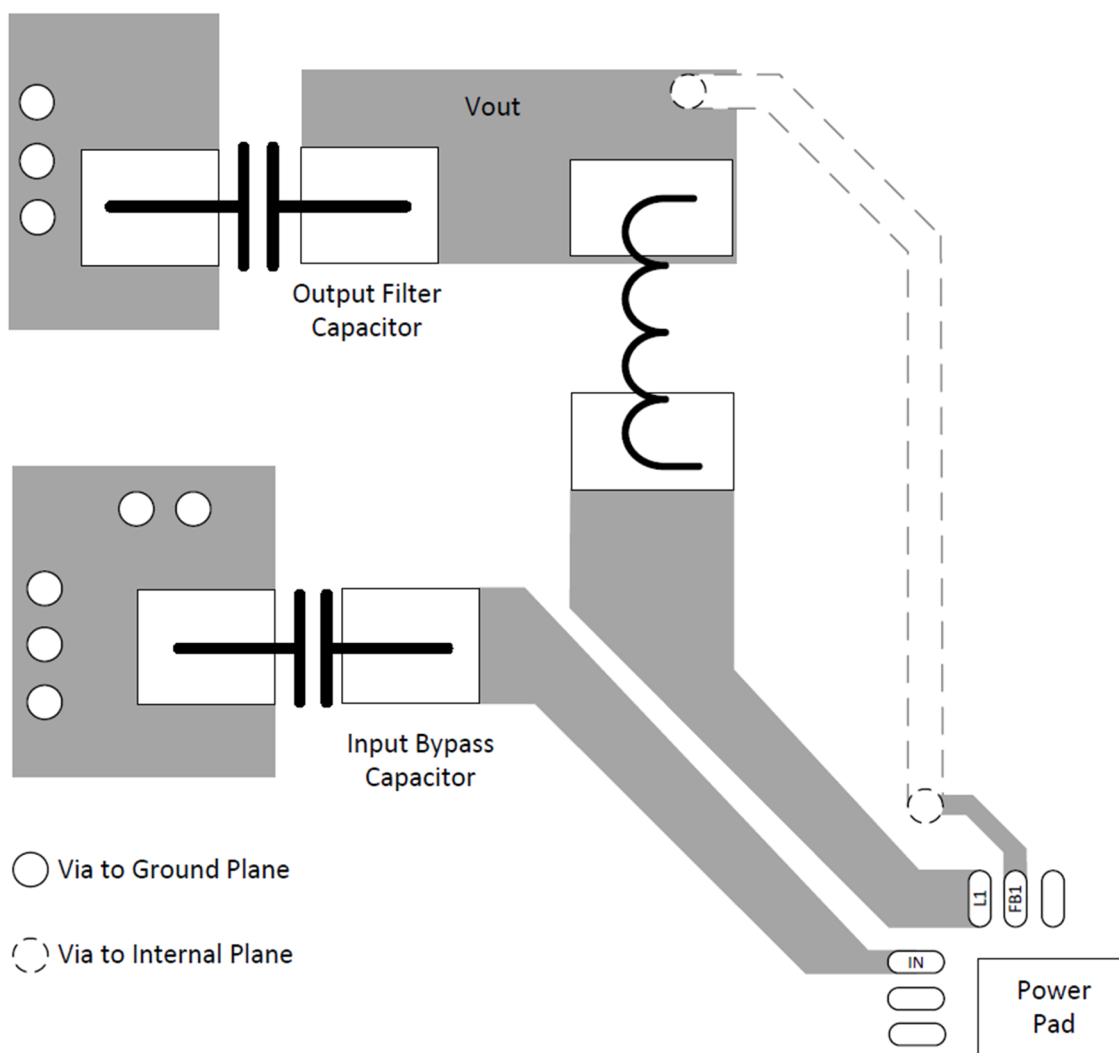

**Figure 72. Layout Example Schematic**



## 13 Device and Documentation Support

### 13.1 Device Support

#### 13.1.1 Third-Party Products Disclaimer

TI'S PUBLICATION OF INFORMATION REGARDING THIRD-PARTY PRODUCTS OR SERVICES DOES NOT CONSTITUTE AN ENDORSEMENT REGARDING THE SUITABILITY OF SUCH PRODUCTS OR SERVICES OR A WARRANTY, REPRESENTATION OR ENDORSEMENT OF SUCH PRODUCTS OR SERVICES, EITHER ALONE OR IN COMBINATION WITH ANY TI PRODUCT OR SERVICE.

### 13.2 Trademarks

Cortex is a trademark of ARM Ltd.

ARM is a registered trademark of ARM Ltd.

I<sup>2</sup>C is a registered trademark of Philips Semiconductors Corporation.

All other trademarks are the property of their respective owners.

### 13.3 Electrostatic Discharge Caution



This integrated circuit can be damaged by ESD. Texas Instruments recommends that all integrated circuits be handled with appropriate precautions. Failure to observe proper handling and installation procedures can cause damage.

ESD damage can range from subtle performance degradation to complete device failure. Precision integrated circuits may be more susceptible to damage because very small parametric changes could cause the device not to meet its published specifications.

### 13.4 Glossary

[SLYZ022](#) — *TI Glossary*.

This glossary lists and explains terms, acronyms, and definitions.

## 14 Mechanical, Packaging, and Orderable Information

The following pages include mechanical, packaging, and orderable information. This information is the most current data available for the designated devices. This data is subject to change without notice and revision of this document. For browser-based versions of this data sheet, refer to the left-hand navigation.

**PACKAGING INFORMATION**

Orderable Device	Status (1)	Package Type	Package Drawing	Pins	Package Qty	Eco Plan (2)	Lead/Ball Finish (6)	MSL Peak Temp (3)	Op Temp (°C)	Device Marking (4/5)	Samples
TPS65217ARSLR	ACTIVE	VQFN	RSL	48	2500	Green (RoHS & no Sb/Br)	CU NIPDAU	Level-3-260C-168 HR	-40 to 105	TPS 65217A	<a href="#">Samples</a>
TPS65217ARSLT	ACTIVE	VQFN	RSL	48	250	Green (RoHS & no Sb/Br)	CU NIPDAU	Level-3-260C-168 HR	-40 to 105	TPS 65217A	<a href="#">Samples</a>
TPS65217BRSLR	ACTIVE	VQFN	RSL	48	2500	Green (RoHS & no Sb/Br)	CU NIPDAU	Level-3-260C-168 HR	-40 to 105	TPS 65217B	<a href="#">Samples</a>
TPS65217BRSLT	ACTIVE	VQFN	RSL	48	250	Green (RoHS & no Sb/Br)	CU NIPDAU	Level-3-260C-168 HR	-40 to 105	TPS 65217B	<a href="#">Samples</a>
TPS65217CRSLR	ACTIVE	VQFN	RSL	48	2500	Green (RoHS & no Sb/Br)	CU NIPDAU	Level-3-260C-168 HR	-40 to 105	TPS 65217C	<a href="#">Samples</a>
TPS65217CRSLT	ACTIVE	VQFN	RSL	48	250	Green (RoHS & no Sb/Br)	CU NIPDAU	Level-3-260C-168 HR	-40 to 105	TPS 65217C	<a href="#">Samples</a>
TPS65217DRSLR	ACTIVE	VQFN	RSL	48	2500	Green (RoHS & no Sb/Br)	CU NIPDAU	Level-3-260C-168 HR	-40 to 105	TPS 65217D	<a href="#">Samples</a>
TPS65217DRSLT	ACTIVE	VQFN	RSL	48	250	Green (RoHS & no Sb/Br)	CU NIPDAU	Level-3-260C-168 HR	-40 to 105	TPS 65217D	<a href="#">Samples</a>

(1) The marketing status values are defined as follows:

**ACTIVE:** Product device recommended for new designs.

**LIFEBUY:** TI has announced that the device will be discontinued, and a lifetime-buy period is in effect.

**NRND:** Not recommended for new designs. Device is in production to support existing customers, but TI does not recommend using this part in a new design.

**PREVIEW:** Device has been announced but is not in production. Samples may or may not be available.

**OBSOLETE:** TI has discontinued the production of the device.

(2) Eco Plan - The planned eco-friendly classification: Pb-Free (RoHS), Pb-Free (RoHS Exempt), or Green (RoHS & no Sb/Br) - please check <http://www.ti.com/productcontent> for the latest availability information and additional product content details.

**TBD:** The Pb-Free/Green conversion plan has not been defined.

**Pb-Free (RoHS):** TI's terms "Lead-Free" or "Pb-Free" mean semiconductor products that are compatible with the current RoHS requirements for all 6 substances, including the requirement that lead not exceed 0.1% by weight in homogeneous materials. Where designed to be soldered at high temperatures, TI Pb-Free products are suitable for use in specified lead-free processes.

**Pb-Free (RoHS Exempt):** This component has a RoHS exemption for either 1) lead-based flip-chip solder bumps used between the die and package, or 2) lead-based die adhesive used between the die and leadframe. The component is otherwise considered Pb-Free (RoHS compatible) as defined above.

**Green (RoHS & no Sb/Br):** TI defines "Green" to mean Pb-Free (RoHS compatible), and free of Bromine (Br) and Antimony (Sb) based flame retardants (Br or Sb do not exceed 0.1% by weight in homogeneous material)

(3) MSL, Peak Temp. - The Moisture Sensitivity Level rating according to the JEDEC industry standard classifications, and peak solder temperature.

(4) There may be additional marking, which relates to the logo, the lot trace code information, or the environmental category on the device.

(5) Multiple Device Markings will be inside parentheses. Only one Device Marking contained in parentheses and separated by a "~" will appear on a device. If a line is indented then it is a continuation of the previous line and the two combined represent the entire Device Marking for that device.

(6) Lead/Ball Finish - Orderable Devices may have multiple material finish options. Finish options are separated by a vertical ruled line. Lead/Ball Finish values may wrap to two lines if the finish value exceeds the maximum column width.

**Important Information and Disclaimer:**The information provided on this page represents TI's knowledge and belief as of the date that it is provided. TI bases its knowledge and belief on information provided by third parties, and makes no representation or warranty as to the accuracy of such information. Efforts are underway to better integrate information from third parties. TI has taken and continues to take reasonable steps to provide representative and accurate information but may not have conducted destructive testing or chemical analysis on incoming materials and chemicals. TI and TI suppliers consider certain information to be proprietary, and thus CAS numbers and other limited information may not be available for release.

In no event shall TI's liability arising out of such information exceed the total purchase price of the TI part(s) at issue in this document sold by TI to Customer on an annual basis.

## TAPE AND REEL INFORMATION



### QUADRANT ASSIGNMENTS FOR PIN 1 ORIENTATION IN TAPE



\*All dimensions are nominal

Device	Package Type	Package Drawing	Pins	SPQ	Reel Diameter (mm)	Reel Width W1 (mm)	A0 (mm)	B0 (mm)	K0 (mm)	P1 (mm)	W (mm)	Pin1 Quadrant
TPS65217ARSLR	VQFN	RSL	48	2500	330.0	16.4	6.3	6.3	1.1	12.0	16.0	Q2
TPS65217ARSLT	VQFN	RSL	48	250	180.0	16.4	6.3	6.3	1.1	12.0	16.0	Q2
TPS65217BRSLR	VQFN	RSL	48	2500	330.0	16.4	6.3	6.3	1.1	12.0	16.0	Q2
TPS65217BRSLT	VQFN	RSL	48	250	180.0	16.4	6.3	6.3	1.1	12.0	16.0	Q2
TPS65217CRSLR	VQFN	RSL	48	2500	330.0	16.4	6.3	6.3	1.1	12.0	16.0	Q2
TPS65217CRSLT	VQFN	RSL	48	250	180.0	16.4	6.3	6.3	1.1	12.0	16.0	Q2
TPS65217DRSLR	VQFN	RSL	48	2500	330.0	16.4	6.3	6.3	1.1	12.0	16.0	Q2
TPS65217DRSLT	VQFN	RSL	48	250	180.0	16.4	6.3	6.3	1.1	12.0	16.0	Q2

**TAPE AND REEL BOX DIMENSIONS**



\*All dimensions are nominal

Device	Package Type	Package Drawing	Pins	SPQ	Length (mm)	Width (mm)	Height (mm)
TPS65217ARSLR	VQFN	RSL	48	2500	367.0	367.0	38.0
TPS65217ARSLT	VQFN	RSL	48	250	210.0	185.0	35.0
TPS65217BRSLR	VQFN	RSL	48	2500	367.0	367.0	38.0
TPS65217BRSLT	VQFN	RSL	48	250	210.0	185.0	35.0
TPS65217CRSLR	VQFN	RSL	48	2500	367.0	367.0	38.0
TPS65217CRSLT	VQFN	RSL	48	250	210.0	185.0	35.0
TPS65217DRSLR	VQFN	RSL	48	2500	367.0	367.0	38.0
TPS65217DRSLT	VQFN	RSL	48	250	210.0	185.0	35.0

# MECHANICAL DATA

RSL (S-PVQFN-N48)

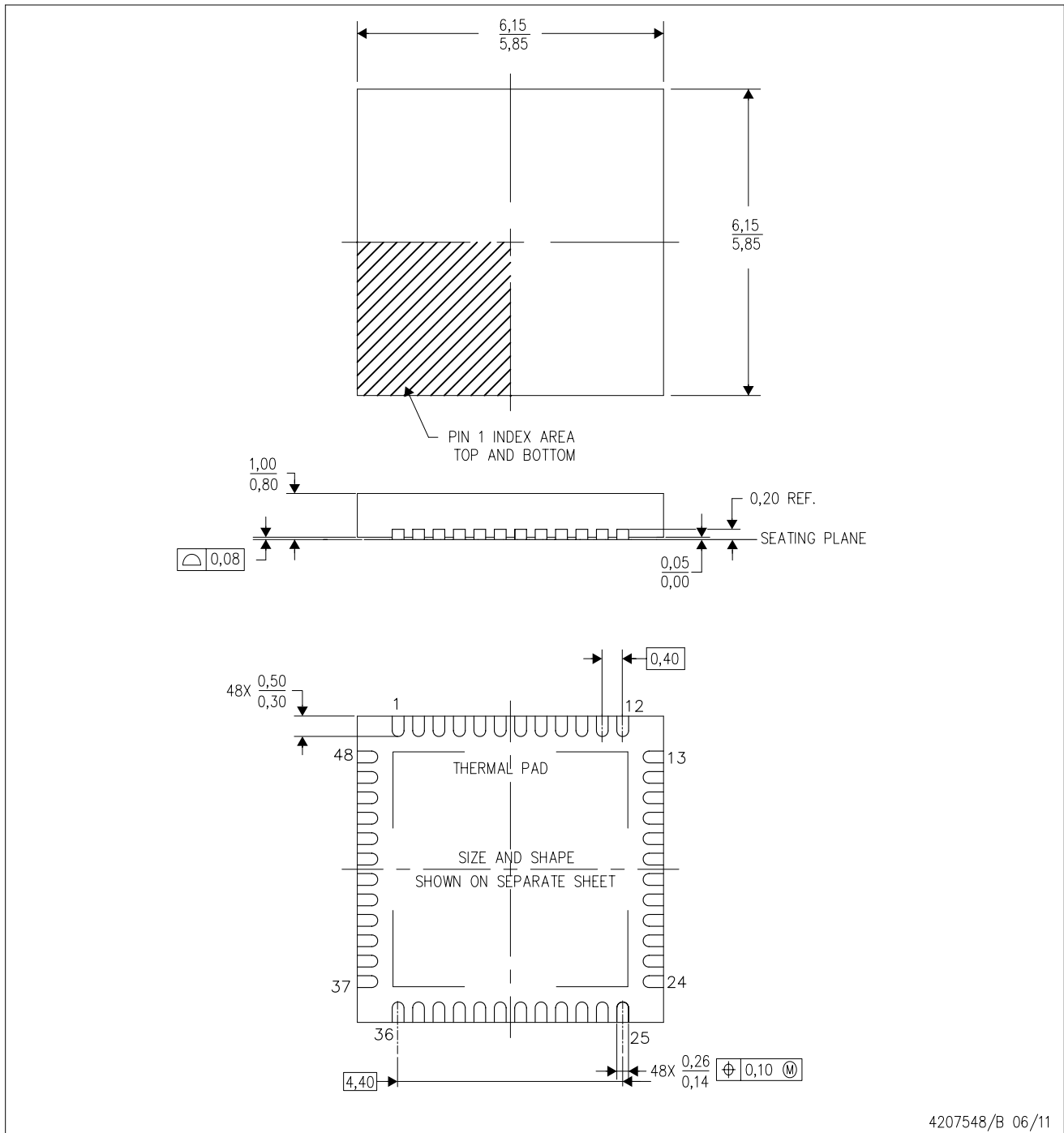
PLASTIC QUAD FLATPACK NO-LEAD



- NOTES:
- All linear dimensions are in millimeters. Dimensioning and tolerancing per ASME Y14.5M-1994.
  - This drawing is subject to change without notice.
  - Quad Flatpack, No-leads (QFN) package configuration.
  - The package thermal pad must be soldered to the board for thermal and mechanical performance.
  - See the additional figure in the Product Data Sheet for details regarding the exposed thermal pad features and dimensions.

# THERMAL PAD MECHANICAL DATA

RSL (S-PVQFN-N48)

PLASTIC QUAD FLATPACK NO-LEAD

## THERMAL INFORMATION

This package incorporates an exposed thermal pad that is designed to be attached directly to an external heatsink. The thermal pad must be soldered directly to the printed circuit board (PCB). After soldering, the PCB can be used as a heatsink. In addition, through the use of thermal vias, the thermal pad can be attached directly to the appropriate copper plane shown in the electrical schematic for the device, or alternatively, can be attached to a special heatsink structure designed into the PCB. This design optimizes the heat transfer from the integrated circuit (IC).

For information on the Quad Flatpack No-Lead (QFN) package and its advantages, refer to Application Report, QFN/SON PCB Attachment, Texas Instruments Literature No. SLUA271. This document is available at [www.ti.com](http://www.ti.com).

The exposed thermal pad dimensions for this package are shown in the following illustration.

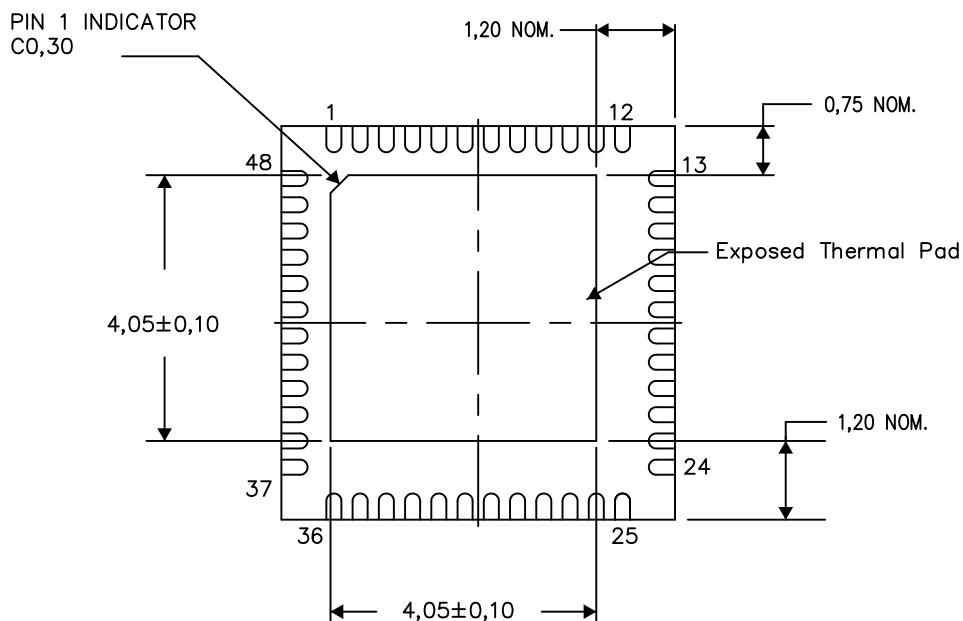

4207841-4/P 03/13

NOTE: All linear dimensions are in millimeters

RSL (S-PVQFN-N48)

PLASTIC QUAD FLATPACK NO-LEAD

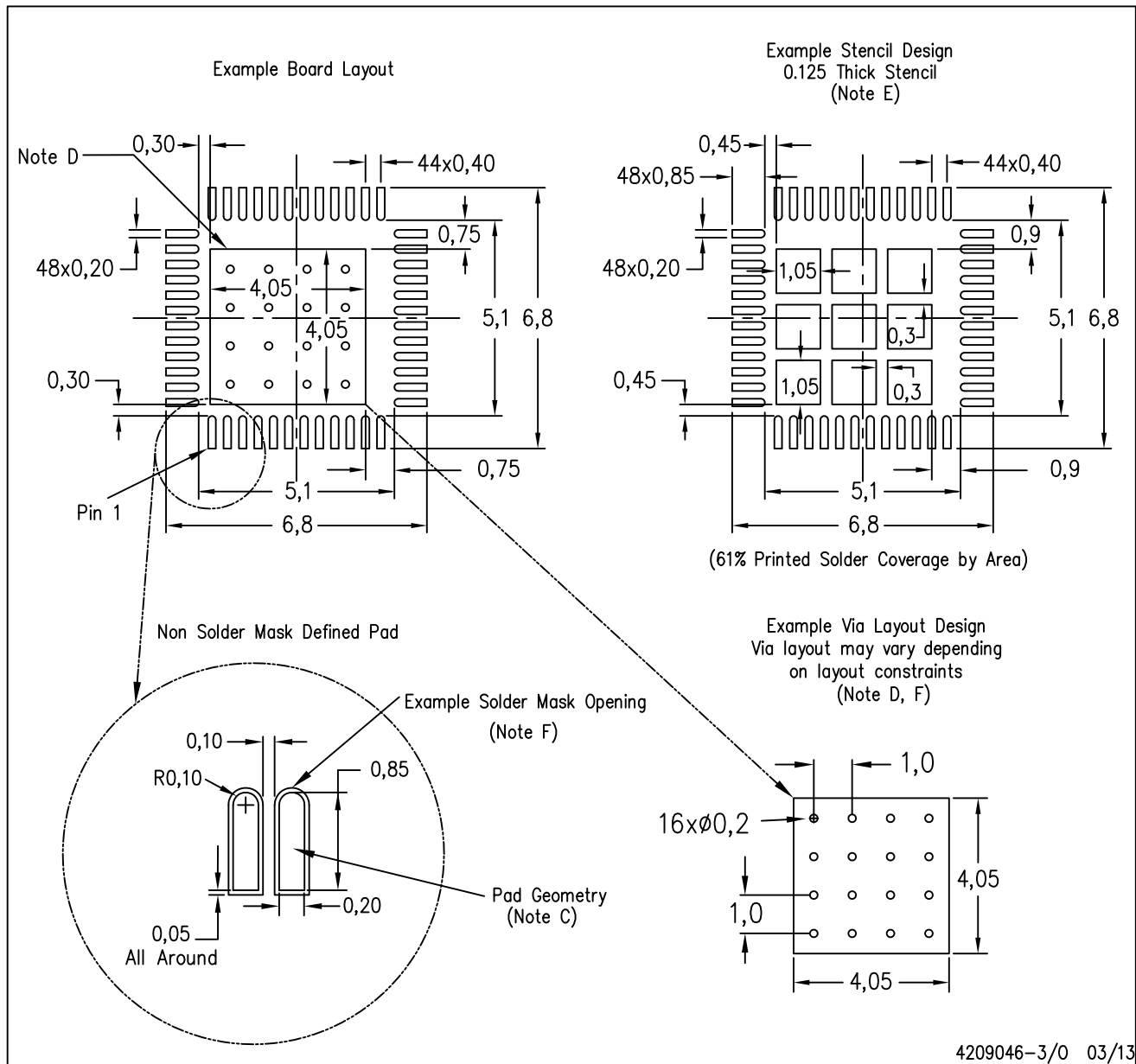

- NOTES:
- All linear dimensions are in millimeters.
  - This drawing is subject to change without notice.
  - Publication IPC-7351 is recommended for alternate designs.
  - This package is designed to be soldered to a thermal pad on the board. Refer to Application Note, QFN/SON PCB Attachment, Texas Instruments Literature No. SLUA271, and also the Product Data Sheets for specific thermal information, via requirements, and recommended board layout. These documents are available at [www.ti.com](http://www.ti.com) <<http://www.ti.com>>.
  - Laser cutting apertures with trapezoidal walls and also rounding corners will offer better paste release. Customers should contact their board assembly site for stencil design recommendations. Refer to IPC 7525 for stencil design considerations.
  - Customers should contact their board fabrication site for recommended solder mask tolerances and via tenting recommendations for vias placed in the thermal pad.



## IMPORTANT NOTICE

Texas Instruments Incorporated and its subsidiaries (TI) reserve the right to make corrections, enhancements, improvements and other changes to its semiconductor products and services per JESD46, latest issue, and to discontinue any product or service per JESD48, latest issue. Buyers should obtain the latest relevant information before placing orders and should verify that such information is current and complete. All semiconductor products (also referred to herein as "components") are sold subject to TI's terms and conditions of sale supplied at the time of order acknowledgment.

TI warrants performance of its components to the specifications applicable at the time of sale, in accordance with the warranty in TI's terms and conditions of sale of semiconductor products. Testing and other quality control techniques are used to the extent TI deems necessary to support this warranty. Except where mandated by applicable law, testing of all parameters of each component is not necessarily performed.

TI assumes no liability for applications assistance or the design of Buyers' products. Buyers are responsible for their products and applications using TI components. To minimize the risks associated with Buyers' products and applications, Buyers should provide adequate design and operating safeguards.

TI does not warrant or represent that any license, either express or implied, is granted under any patent right, copyright, mask work right, or other intellectual property right relating to any combination, machine, or process in which TI components or services are used. Information published by TI regarding third-party products or services does not constitute a license to use such products or services or a warranty or endorsement thereof. Use of such information may require a license from a third party under the patents or other intellectual property of the third party, or a license from TI under the patents or other intellectual property of TI.

Reproduction of significant portions of TI information in TI data books or data sheets is permissible only if reproduction is without alteration and is accompanied by all associated warranties, conditions, limitations, and notices. TI is not responsible or liable for such altered documentation. Information of third parties may be subject to additional restrictions.

Resale of TI components or services with statements different from or beyond the parameters stated by TI for that component or service voids all express and any implied warranties for the associated TI component or service and is an unfair and deceptive business practice. TI is not responsible or liable for any such statements.

Buyer acknowledges and agrees that it is solely responsible for compliance with all legal, regulatory and safety-related requirements concerning its products, and any use of TI components in its applications, notwithstanding any applications-related information or support that may be provided by TI. Buyer represents and agrees that it has all the necessary expertise to create and implement safeguards which anticipate dangerous consequences of failures, monitor failures and their consequences, lessen the likelihood of failures that might cause harm and take appropriate remedial actions. Buyer will fully indemnify TI and its representatives against any damages arising out of the use of any TI components in safety-critical applications.

In some cases, TI components may be promoted specifically to facilitate safety-related applications. With such components, TI's goal is to help enable customers to design and create their own end-product solutions that meet applicable functional safety standards and requirements. Nonetheless, such components are subject to these terms.

No TI components are authorized for use in FDA Class III (or similar life-critical medical equipment) unless authorized officers of the parties have executed a special agreement specifically governing such use.

Only those TI components which TI has specifically designated as military grade or "enhanced plastic" are designed and intended for use in military/aerospace applications or environments. Buyer acknowledges and agrees that any military or aerospace use of TI components which have **not** been so designated is solely at the Buyer's risk, and that Buyer is solely responsible for compliance with all legal and regulatory requirements in connection with such use.

TI has specifically designated certain components as meeting ISO/TS16949 requirements, mainly for automotive use. In any case of use of non-designated products, TI will not be responsible for any failure to meet ISO/TS16949.

### Products

Audio	<a href="http://www.ti.com/audio">www.ti.com/audio</a>
Amplifiers	<a href="http://amplifier.ti.com">amplifier.ti.com</a>
Data Converters	<a href="http://dataconverter.ti.com">dataconverter.ti.com</a>
DLP® Products	<a href="http://www.dlp.com">www.dlp.com</a>
DSP	<a href="http://dsp.ti.com">dsp.ti.com</a>
Clocks and Timers	<a href="http://www.ti.com/clocks">www.ti.com/clocks</a>
Interface	<a href="http://interface.ti.com">interface.ti.com</a>
Logic	<a href="http://logic.ti.com">logic.ti.com</a>
Power Mgmt	<a href="http://power.ti.com">power.ti.com</a>
Microcontrollers	<a href="http://microcontroller.ti.com">microcontroller.ti.com</a>
RFID	<a href="http://www.ti-rfid.com">www.ti-rfid.com</a>
OMAP Applications Processors	<a href="http://www.ti.com/omap">www.ti.com/omap</a>
Wireless Connectivity	<a href="http://www.ti.com/wirelessconnectivity">www.ti.com/wirelessconnectivity</a>

### Applications

Automotive and Transportation	<a href="http://www.ti.com/automotive">www.ti.com/automotive</a>
Communications and Telecom	<a href="http://www.ti.com/communications">www.ti.com/communications</a>
Computers and Peripherals	<a href="http://www.ti.com/computers">www.ti.com/computers</a>
Consumer Electronics	<a href="http://www.ti.com/consumer-apps">www.ti.com/consumer-apps</a>
Energy and Lighting	<a href="http://www.ti.com/energy">www.ti.com/energy</a>
Industrial	<a href="http://www.ti.com/industrial">www.ti.com/industrial</a>
Medical	<a href="http://www.ti.com/medical">www.ti.com/medical</a>
Security	<a href="http://www.ti.com/security">www.ti.com/security</a>
Space, Avionics and Defense	<a href="http://www.ti.com/space-avionics-defense">www.ti.com/space-avionics-defense</a>
Video and Imaging	<a href="http://www.ti.com/video">www.ti.com/video</a>

### TI E2E Community

[e2e.ti.com](http://e2e.ti.com)

# Mouser Electronics

Authorized Distributor

Click to View Pricing, Inventory, Delivery & Lifecycle Information:

## Texas Instruments:

[TPS65217ARSLR](#) [TPS65217BRSLR](#) [TPS65217ARSLT](#) [TPS65217BRSLT](#) [TPS65217CRSLR](#) [TPS65217CRSLT](#)  
[TPS65217DRSLR](#) [TPS65217DRSLT](#)