

RoHS

SPECIFICATION

SMA MALE CRIMP CONNECTOR  
 RG174, NICKEL PLATED ( TGN )  
 SMA ♂, CRIMP TYPE ,RG174,鐵弗龍絕緣, 本體: 鍍鎳, PIN : 鍍金

ITEM NO: TL4000-174-BTNG (Ni)  
 TL4000-316-BTNG (Ni)  
 TL4000-174-BTGG (GOLDEN)  
 TL4000-316-BTGG (GOLDEN)

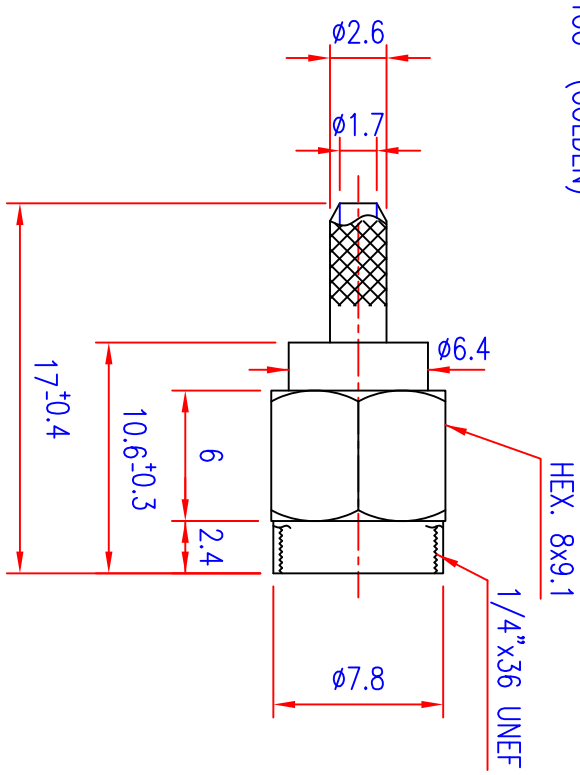
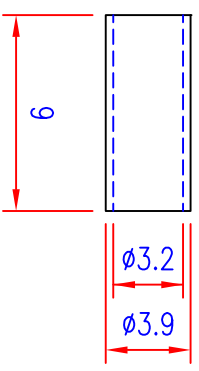
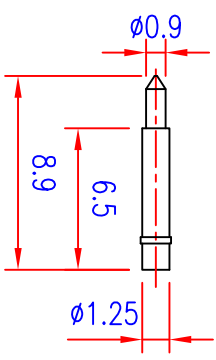

NOTES:FINISH(PLATING THICKNESS IN MICRO-INCHES)

- 1.BRASS PER QQ-B-626
- 2.NICKEL PL 70 MIN THICK OVER COPPER STRIKE
- 3.GOLD PL 3 MIN OVER NICKEL PL 70 MIN THICK OVER COPPER STRIKE
- 4.TEFLON MIL-P-19468
- 5.BERYLLIUM COPPER PER QQ-C-530
- 6.BRASS PER QQ-B-613

UNLESS OTHERWISE SPECIFIED  
 GENERAL TOLERANCES  
 0.5~6 = ±0.2  
 >6~30 = ±0.4  
 >30~120 = ±0.6

SMA MALE CRIMP CONNECTOR

5	CONTACT PIN	NOTE 1	NOTE 1	NOTE 3	
4	SHELL	NOTE 1	NOTE 1	NOTE 2	
3	C RING	NOTE 5		NONE	
2	INSULATOR	NOTE 4		WHITE	
1	BODY	NOTE 1		NOTE 2	
NO.	DESCRIPTION	QTY	MATERIAL	SPECIFICATION	FINISH
DRAW BY	周鳳君	021508	1 : 3	PROJ	ITEM NO. TL4000-174-BTNG
DEGN BY					REMARK
APPD BY			MM		

同利企業有限公司

TELE LONG ENTERPRISE CO.,LTD

DATE	DRAWNG BY	REVISED	△
------	-----------	---------	---

DWG NO.	TL4000-174-BTNG -TNS61-C
---------	-----------------------------

SPECIFICATION

SMA MALE CONNECTOR  
 CRIMP TYPE , RG58, TEFLON INSULATION  
 NICKEL PLATED , PIN: GOLD PLATED  
 SMA 公, CRIMP TYPE , RG58, 鍍鎳鍏抽, 本體鍍鎳, PIN:鍍金  
 符合ROHS指令

ITEM NO: TL4000-174-BTNG (NI)  
 TL4000-58-BTGG (GOLDEN)

ROHS

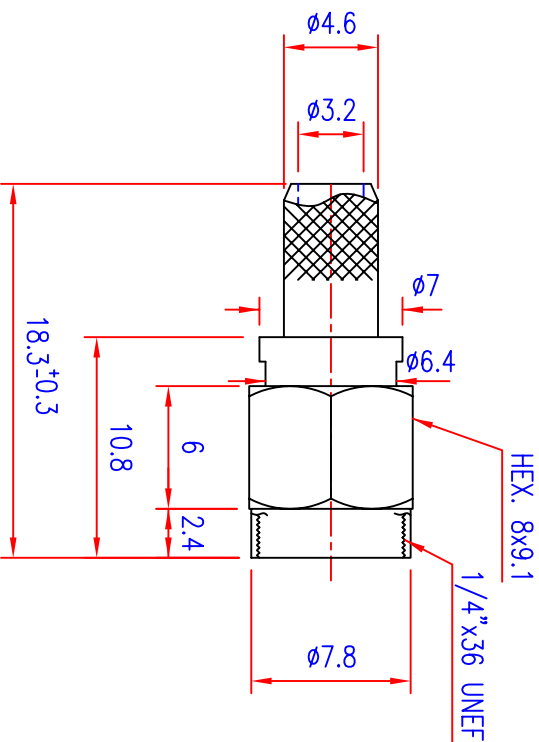
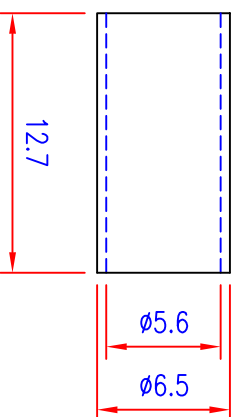
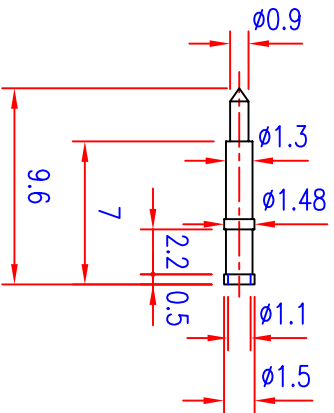

NOTES:FINISH(PLATING THICKNESS IN MICRO-INCHES)

- 1.BRASS PER QQ-B-626
- 2.NICKEL PL 70 MIN THICK OVER COPPER STRIKE
- 3.GOLD PL 3 MIN OVER NICKEL PL 70 MIN THICK OVER COPPER STRIKE
- 4.TEFLON MIL-P-19468
- 5.BERYLLIUM COPPER PER QQ-C-530
- 6.BRASS PER QQ-B-613

**UNLESS OTHERWISE SPECIFIED  
 GENERAL TOLERANCES**  
 0.5~6 = ±0.2  
 >6~30 = ±0.4  
 >30~120 = ±0.6

SMA MALE CRIMP TYPE

5	CONTACT PIN	NOTE 1		NOTE 1		NOTE 3	
4	SHELL	NOTE 1		NOTE 1		NOTE 2	
3	C RING	NOTE 5		NOTE 5		NONE	
2	INSULATOR	NOTE 4		NOTE 4		WHITE	
1	BODY	NOTE 1		NOTE 1		NOTE 2	
NO.	DESCRIPTION	QTY	MATERIAL	SPECIFICATION	FINISH	REMARK	
DRAW BY	風輝碧	021508	SCALE	1 : 3	PROJ	ITEM NO.	TL4000-58-BTNG
DEGN BY			UNIT	MM		TITLE	SMA CONNECTOR
APPD BY						DWG NO.	TL4000-58-BTNG -TNS61-C

同利企業有限公司

TELE LONG ENTERPRISE CO.,LTD  
 E-mail:royyang@seed.net.tw

DATE DRAWG BY REVISED