



AUO Confidential
For PROMATE Internal Use Only
2018/205 10:01:24

(V) Preliminary Specification
() Final Specification

Module	22.9" Color TFT-LCD
Model Name	G229HAN01.0

Customer	Date
_____	_____
Checked & Approved by	
_____	_____
Note: This Specification is subject to change without notice.	

Approved by	Date
<u>Crystal Hsieh</u>	<u>2018/08/27</u>
Prepared by	
<u>Athena Wu</u>	<u>2018/08/27</u>
General Display Business Unit/ AU Optronics corporation	

AUO Confidential
For PROMATE Internal Use Only
2018/205 10:01:24

Contents

1.0 Handling Precautions	4
2.0 General Description	5
2.1 Display Characteristics.....	5
2.2 Optical Characteristics	6
3.0 Functional Block Diagram	9
4.0 Absolute Maximum Ratings	10
4.1 TFT LCD Module.....	10
4.2 Absolute Ratings of Environment	10
5.0 Electrical characteristics	11
5.1 TFT LCD Module.....	11
5.1.1 Power Specification.....	11
5.1.2 Signal Electrical Characteristics	12
5.2 Backlight Unit	13
6.0 Signal Characteristic	14
6.1 Pixel Format Image	14
6.2 The input data format	15
6.3 Signal Description	16
6.4 Timing Characteristics	18
6.5 Timing diagram.....	19
6.6 Power ON/OFF Sequence	20
7.0 Connector & Pin Assignment	21
7.1 TFT LCD Module.....	21
7.2 LED Backlight Unit: LED Driver Connector	21
7.3 LED Driver Connector Pin Assignment	22
8.0 Reliability Test	23
9.0 Shipping Label & Packaging	24
9.1 Shipping Label	24
9.2 Packaging	25
9.3 Shipping Package of Palletizing Sequence.....	26
10.0 Mechanical Characteristics	27
11 Safety	28
11.1 Sharp Edge Requirements	28
11.2 Materials.....	28
11.2.1 Toxicity.....	28
11.2.2 Flammability.....	28
11.3 Capacitors	28
11.4 National Test Lab Requirement	28



Record of Revision

Version & Date	Page	Old description	New Description
0.0 / 2018/08/27			Preliminary Specification

AUO Confidential
For PROMATE Internal Use Only
2018/205 10:01:24

1.0 Handling Precautions

- 1) Since front polarizer is easily damaged, pay attention not to scratch it.
- 2) Be sure to turn off power supply when inserting or disconnecting from input connector.
- 3) Wipe off water drop immediately. Long contact with water may cause discoloration or spots.
- 4) When the panel surface is soiled, wipe it with absorbent cotton or other soft cloth.
- 5) Since the panel is made of glass, it may break or crack if dropped or bumped on hard surface.
- 6) Since CMOS LSI is used in this module, take care of static electricity and insure human earth when handling.
- 7) Do not open or modify the Module Assembly.
- 8) Do not press the reflector sheet at the back of the module to any directions.
- 9) In case if a Module has to be put back into the packing container slot after it was taken out from the container, do not press the center of LED lightbar edge. Instead, press at the far ends of the LED light bar edge softly. Otherwise the TFT Module may be damaged.
- 10) At the insertion or removal of the Signal Interface Connector, be sure not to rotate nor tilt the Interface Connector of the TFT Module.
- 11) After installation of the TFT Module into an enclosure, do not twist nor bend the TFT Module even momentarily. While designing the enclosure, it should be taken into consideration that no bending/twisting forces are applied to the TFT Module from outside. Otherwise the TFT Module may be damaged.
- 12) Small amount of materials having no flammability grade is used in the LCD module. The LCD module should be supplied by power complied with requirements of Limited Power Source (IEC60950-1 or UL60950-1), or be applied exemption.

2.0 General Description

This specification applies to the 22.9 inch-wide Color AHVA (IPS-like) TFT-LCD Module G229HAN01.0. The display supports the FHD [1920(H) x 165(V)] screen format and 16.7M colors (True 8 bit). All input signals are LVDS interface compatible.

2.1 Display Characteristics

The following items are characteristics summary on the table under 25°C condition:

ITEMS	Unit	SPECIFICATIONS
Screen Diagonal	[mm]	581.01(22.9")
Active Area	[mm]	578.88 (H) x 49.7475 (V)
Pixels H x V		1920x165
Pixel Pitch	[um]	301.5 × 301.5
Pixel Arrangement		R.G.B. Vertical Stripe
Display Mode		AHVA mode, Normally black
White Luminance (Center)	[cd/m ²]	500 cd/m ² (Typ.)
Contrast Ratio		1000 (Typ.)
Optical Response Time	[msec]	25ms
Nominal Input Voltage VDD	[Volt]	5V (Typ)
Power Consumption (VDD line + LED line)	[Watt]	7.53W
Weight	[Grams]	460 (Typ)
Physical Size	[mm]	587.08 (H) x 62.05 (V) x10.21 (D) Typ
Electrical Interface		Single LVDS
Support Color		16.7M colors, True 8 bit
Surface Treatment		Anti-Glare, 3H
RoHS Compliance		RoHS Compliance
Temperature Range		
Operating	[°C]	0~ 50
Storage (Shipping)	[°C]	-20~ 60

2.2 Optical Characteristics

The optical characteristics are measured under stable conditions at 25 °C:

Item	Unit	Conditions	Min.	Typ.	Max.	Note
Viewing Angle	[degree]	Horizontal (Right) CR >10		89	-	2
		(Left)		89	-	
		Vertical (Up) CR > 10		89	-	
		(Down)		89	-	
Contrast ratio		Normal Direction	800	1000	-	3
Response Time	[msec]	Raising Time (T _{rR})		13		4
		Falling Time (T _{rF})		12		
		Raising + Falling		25		
Color / Chromaticity Coordinates (CIE)		Red x	TBD	TBD	TBD	5
		Red y	TBD	TBD	TBD	
		Green x	TBD	TBD	TBD	
		Green y	TBD	TBD	TBD	
		Blue x	TBD	TBD	TBD	
		Blue y	TBD	TBD	TBD	
Color Coordinates (CIE) White		White x	TBD	TBD	TBD	
		White y	TBD	TBD	TBD	
Central Luminance	[cd/m ²]		400	500		6
Luminance Uniformity	[%]		70	75		7
Color Gamut	%			72		

Note 1: Measurement method

The LCD module should be stabilized at given temperature for 30 minutes to avoid abrupt temperature change during measuring (at surface 35°C). In order to stabilize the luminance, the measurement should be executed after lighting Backlight for 30 minutes in a stable, windless and dark room.

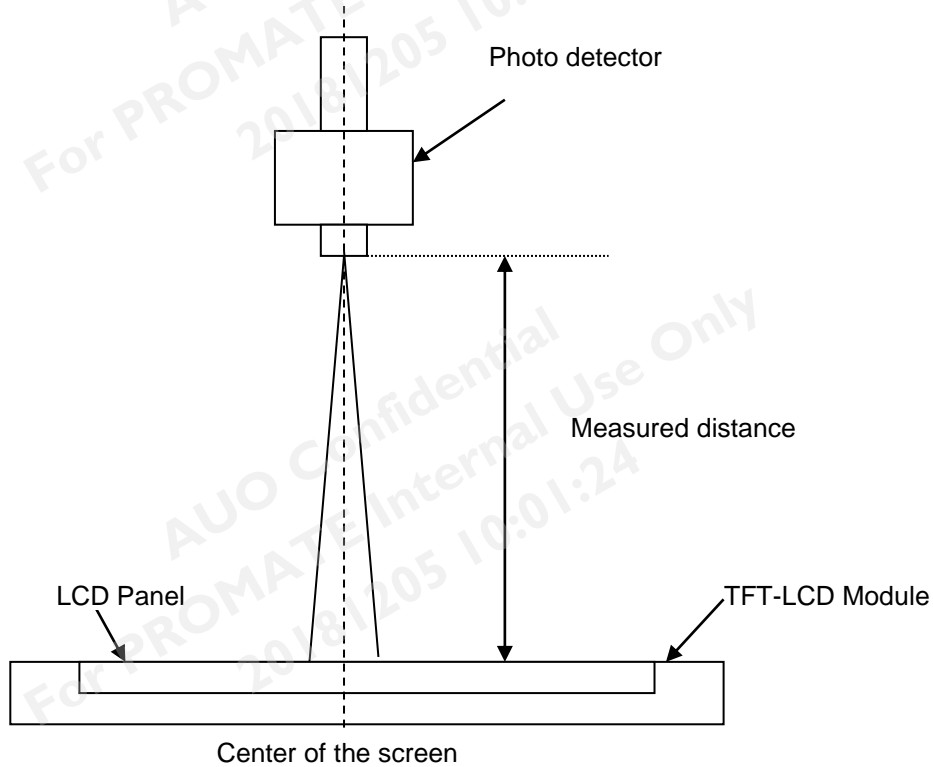

Note 2: Definition of viewing angle measured by ELDIM (EZContrast 88)

Viewing angle is the measurement of contrast ratio ≥ 10 , at the screen center, over a 180° horizontal and 180° vertical range (off-normal viewing angles). The 180° viewing angle range is broken down as follows; 90° (θ) horizontal left and right and 90° (Φ) vertical, high (up) and low (down). The measurement direction is typically perpendicular to the display surface with the screen rotated about its center to develop the desired measurement viewing angle.

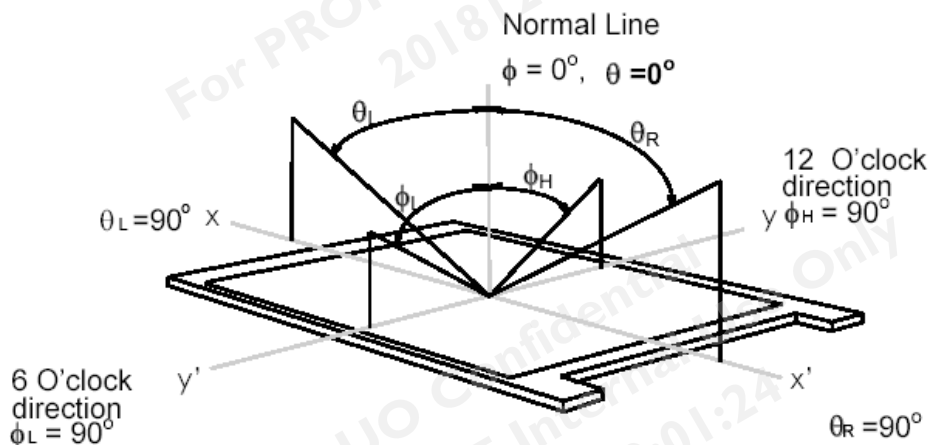

Note 3: Contrast ratio is measured by TOPCON SR-3

Note 4: Definition of Response time measured by Westar TRD-100A

The output signals of photo detector are measured when the input signals are changed from “Full Black” to “Full White” (rising time, Tr_R), and from “Full White” to “Full Black” (falling time, Tr_F), respectively. The response time is interval between the 10% and 90% (1 frame at 60 Hz) of amplitudes. $Tr_R + Tr_F = 5$ msec (typ.).

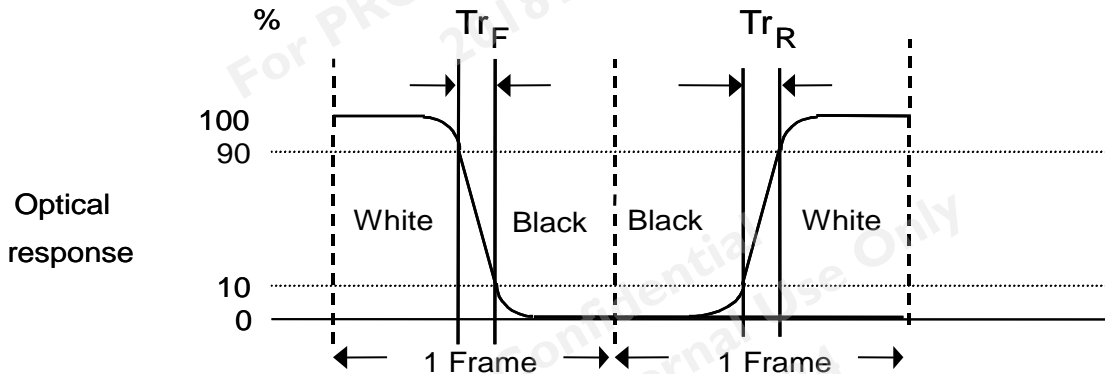

Note 5: Color chromaticity and coordinates (CIE) is measured by TOPCON SR-3

Note 6: Central luminance is measured by TOPCON SR-3

Note 7: Luminance uniformity of these 5 points is defined as below and measured by TOPCON SR-3

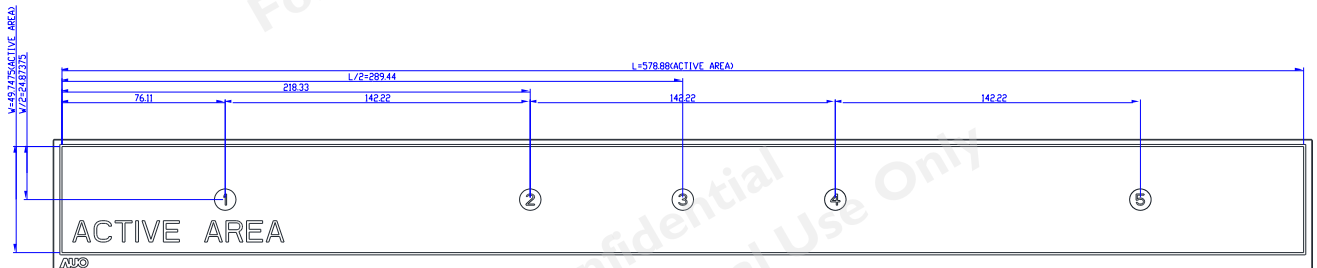

$$\text{Uniformity} = \frac{\text{Minimum Luminance in 9 points (1-5)}}{\text{Maximum Luminance in 9 Points (1-5)}}$$

3.0 Functional Block Diagram

The following diagram shows the functional block of the 22.9 inch Color TFT-LCD Module:

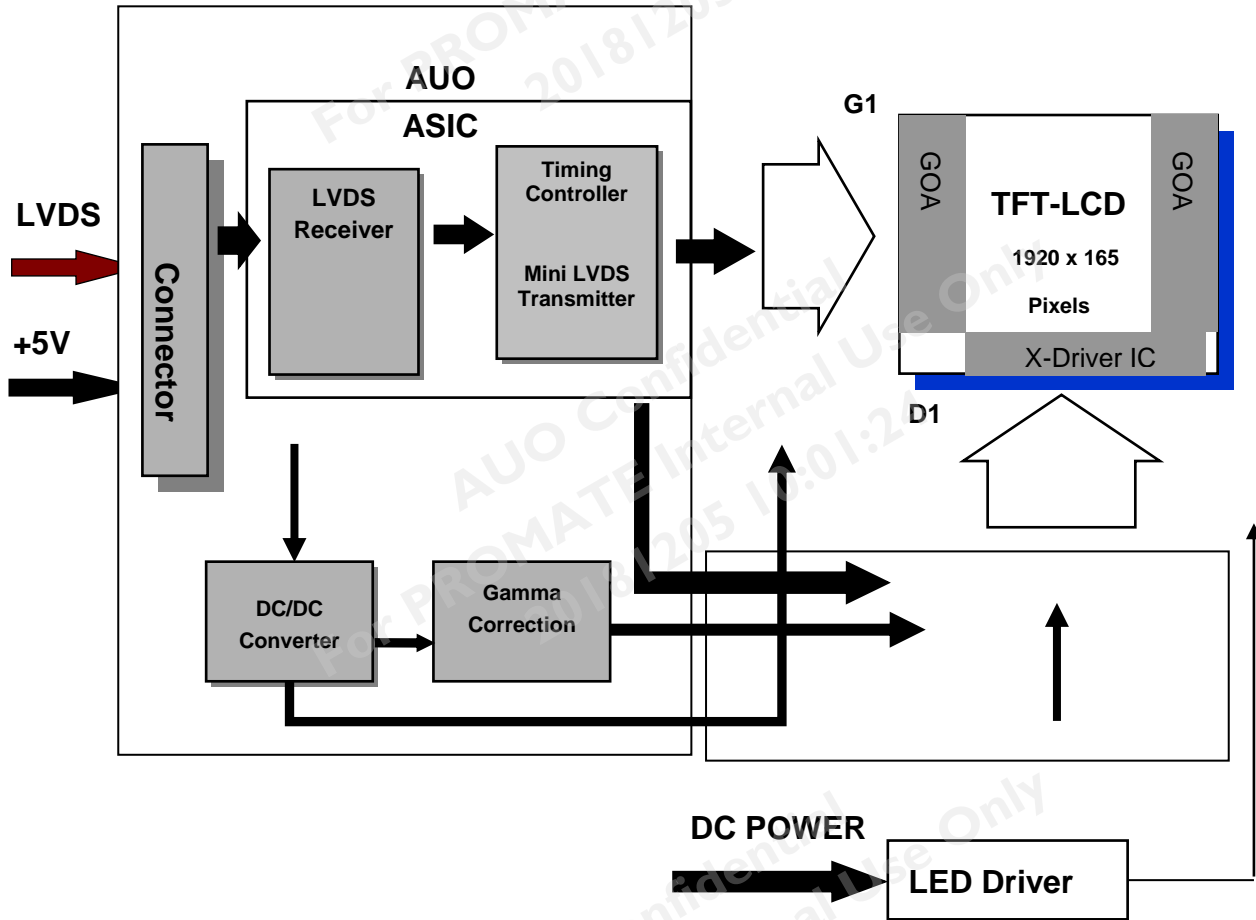

I/F PCB Interface:

MSBKT2407P30HB

Mating Type:

FI-X30C2EL or compatible

4.0 Absolute Maximum Ratings

Absolute maximum ratings of the module are as following:

4.1 TFT LCD Module

Item	Symbol	Min	Max	Unit	Conditions
Logic/LCD Drive Voltage	VDD	-0.3	+5.5	[Volt]	Note 1,2

4.2 Absolute Ratings of Environment

Item	Symbol	Min.	Max.	Unit	Conditions
Operating Temperature	TOP	0	50	[°C]	Note 3 & 4
Operation Humidity	HOP	5	80	[%RH]	
Storage Temperature	TST	-20	60	[°C]	
Storage Humidity	HST	5	80	[%RH]	

Note 1: With in Ta (25 °C)

Note 2: Permanent damage to the device may occur if exceeding maximum values

Note 3: For quality performance, please refer to AUO IIS(Incoming Inspection Standard).

Note 4: Operation Temperature +60°C is defined as panel surface temperature.

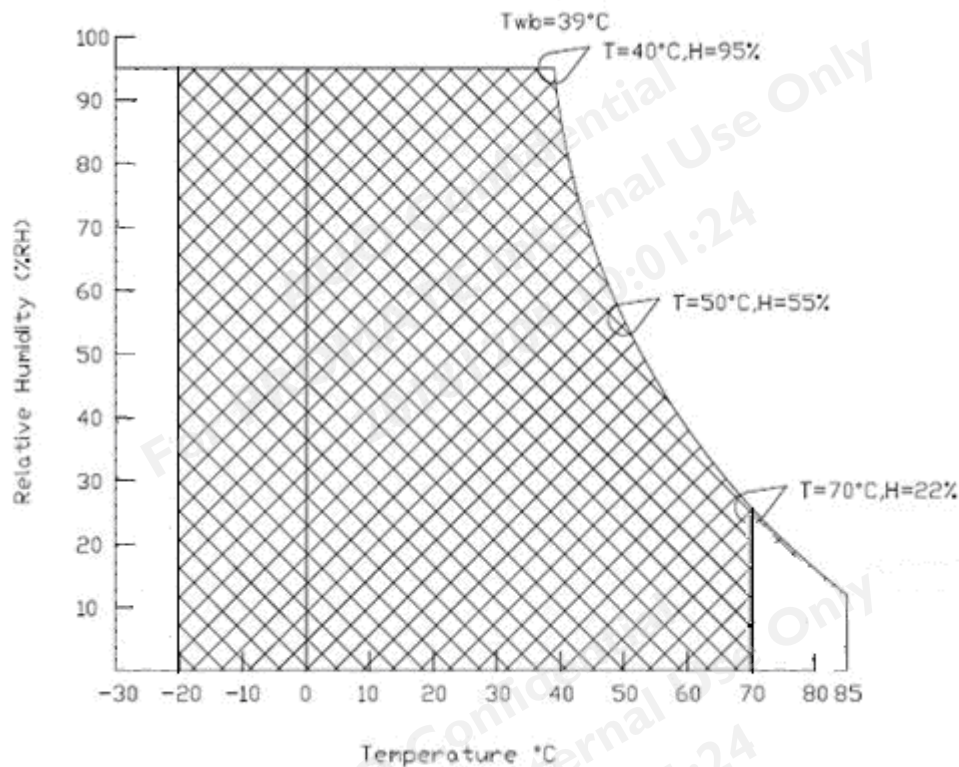

5.0 Electrical characteristics

5.1 TFT LCD Module

5.1.1 Power Specification

Input power specifications are as follows:

Symbol	Parameter	Min	Typ	Max	Unit	Conditions
VDD	Logic/LCD Drive Voltage	4.5	5.0	5.5	[Volt]	+/-10%
IDD	Input Current	-	0.37	0.44	[A]	VDD= 5.0V, All White Pattern At 60Hz,
PDD	VDD Power	-	1.85	2.2	[Watt]	VDD= 5.0V, All White Pattern At 60Hz
IRush	Inrush Current	-	-	3	[A]	Note 1
VDDrp	Allowable Logic/LCD Drive Ripple Voltage	-	-	300	[mV] p-p	VDD= 5.0V, All White Pattern At 60Hz

Note 1: Measurement conditions:

The duration of rising time of power input is 470us.

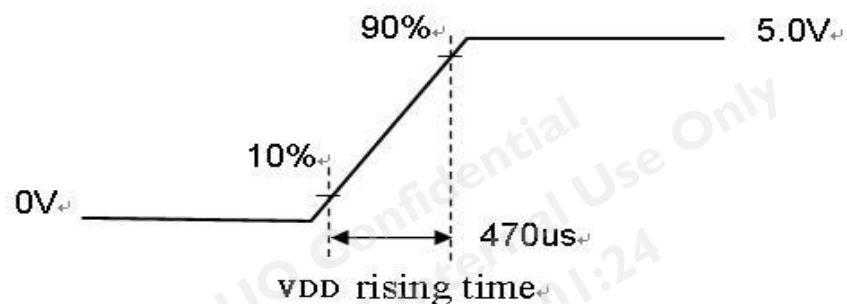
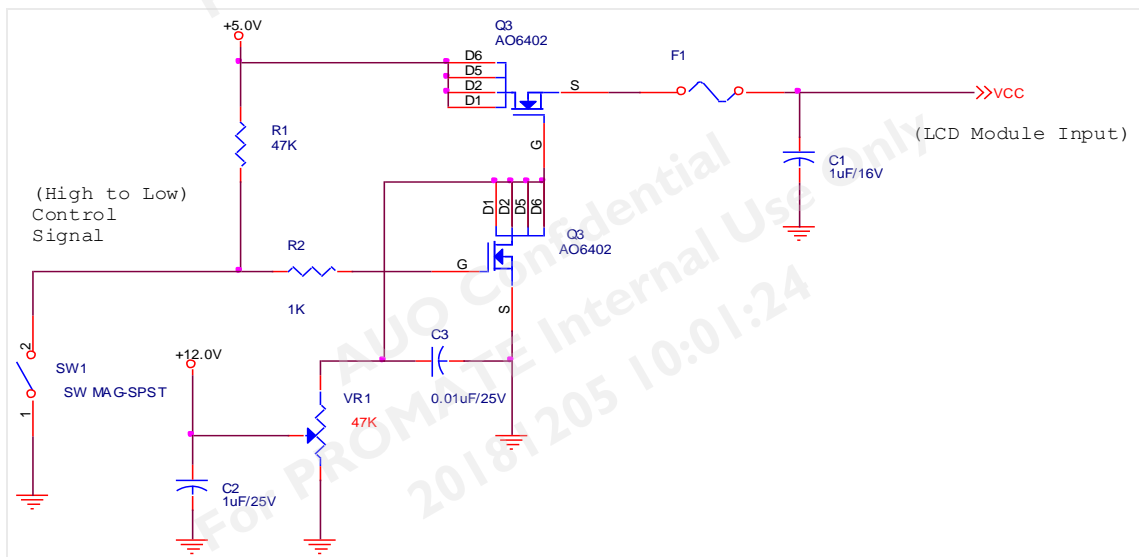

5.1.2 Signal Electrical Characteristics

Input signals shall be low or Hi-Z state when VDD is off. Please refer to specifications of SN75LVDS82DGG (Texas Instruments) in detail.

Characteristics of each signal are as follows:

Symbol	Parameter	Min	Typ	Max	Units	Condition
VTH	Differential Input High Threshold	-		+100	-	VICM = 1.2V Note 1
VTL	Differential Input Low Threshold	-100		-	-100	VICM = 1.2V Note 1
VID	Input Differential Voltage	100	-	600	100	Note 1
VICM	Differential Input Common Mode Voltage	+1.0	+1.2	+1.5	+1.0	VTH-VTL = 200MV (max) Note 1

Note 1: LVDS Signal Waveform

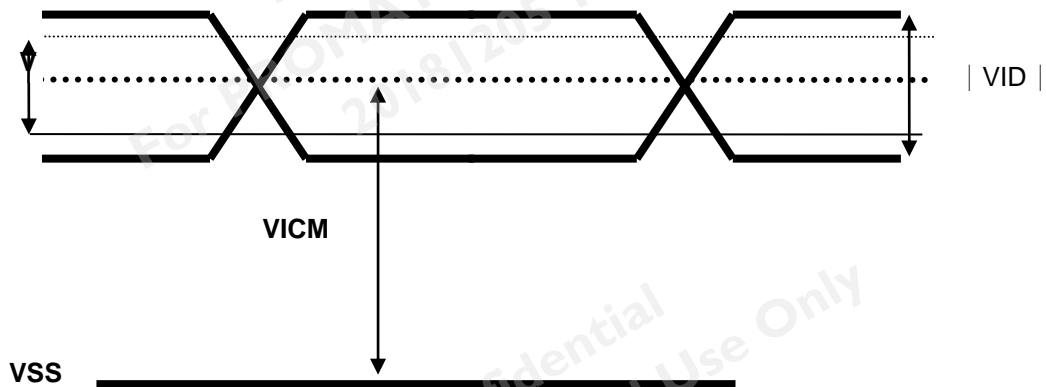

5.2 Backlight Unit

Following characteristics are measured under a stable condition at 25 °C (Room Temperature):

Symbol	Parameter	Min.	Typ.	Max.	Unit	Remark
VCC	Input Voltage	10.8	12	13.2	[Volt]	
Ivcc	Input Current		0.47	0.56	[A]	100% PWM Duty
Pvcc	Power Consumption		5.7	6.72	[Watt]	100% PWM Duty
Irush LED	Inrush Current	-		3	[A]	at rising time=470us
VLED on/off	On Control Voltage	3	5	5.5	Volt	
	Off Control Voltage			0.8	Volt	
F _{PWM}	Dimming Frequency	200	-	20k	[Hz]	
	Swing Voltage	3	3.3	5	V	
	High Voltage	3	3.3	5	Volt	
	Low Voltage			0.8	Volt	
	Dimming Duty Cycle	5	-	100	%	
I _F	LED Forward Current		55		mA	Ta = 25 °C
V _F	LED Forward Voltage	-	3.1	3.4	Volt	I _F 18=mA, Ta = 25°C
P _{LED}	LED Power Consumption	-		12.5	Watt	I _F 18=mA, Ta = 25°C
Operation Lifetime		50,000			Hrs	I _F 18=mA, Ta= 25°C

Note 1: Ta means ambient temperature of TFT-LCD module.

Note 2: VCC, Ivcc, Pvcc, Irush LED are defined for LED B/L.(100% duty of PWM dimming)

Note 3: I_F, V_F, P_{LED} are defined for single LED.

Note 4: If G229HAN01.0 module is driven by high current or at high ambient temperature & humidity condition. The operating life will be reduced.

Note 5: Operation life means brightness goes down to 50% initial brightness. Minimum operating life time is estimated data.

Note 6: Each LED light bar consists of 48 pcs LED package (8 strings x 6 parallel x 2 pcs)

6.2 The input data format

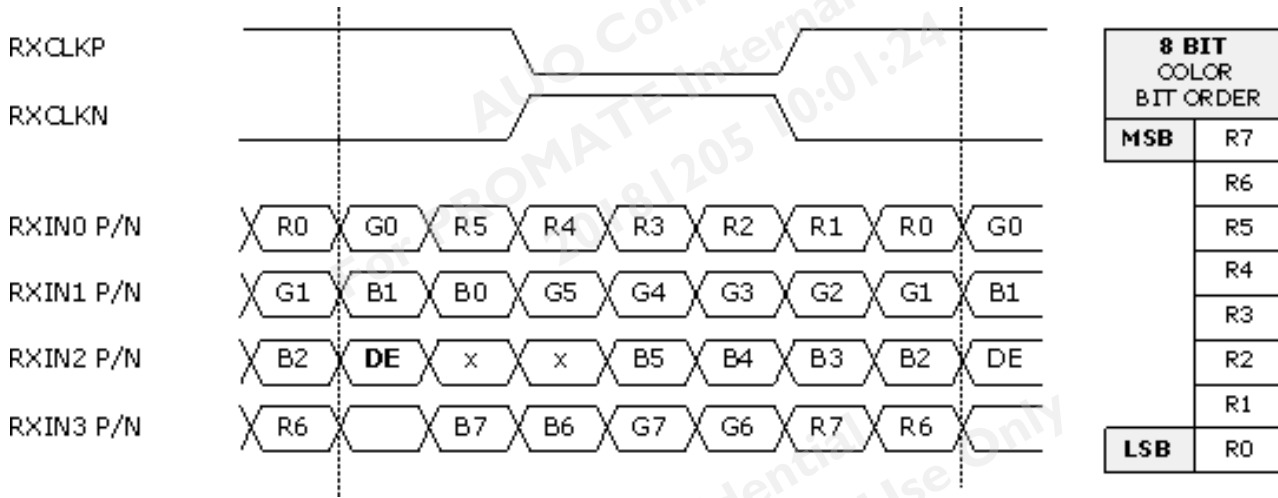

Note1: Normally DE mode only.

Note2: Please follow VESA.

Note3: 8-bits signal input.

6.3 Signal Description

The module using a pair of LVDS receiver **SN75LVDS82 / SN75LVDS83**

(Texas Instruments) or compatible. LVDS is a differential signal technology for LCD interface and high speed data transfer device. Transmitter shall be SN75LVDS83(negative edge sampling) or compatible. The first LVDS port(RxOxxx) transmits odd pixels while the second LVDS port(RxExxx) transmits even pixels.

PIN #	SIGNAL NAME	I/O	DESCRIPTION
1	NC	--	No contact (For AUO internal use)
2	NC	--	No contact (For AUO internal use)
3	NC	--	No contact (For AUO internal use)
4	GND	G	Power Ground
5	RXIN0N	I	Negative LVDS differential data input (0)
6	RXIN0P	I	Positive LVDS differential data input (0)
7	GND	G	Power Ground
8	RXIN1N	I	Negative LVDS differential data input (1)
9	RXIN1P	I	Positive LVDS differential data input (1)
10	GND	G	Power Ground
11	RXIN2N	I	Negative LVDS differential data input (2)
12	RXIN2P	I	Positive LVDS differential data input (2)
13	GND	G	Power Ground
14	RXINCLKN	I	Negative LVDS differential clock input (clock)
15	RXINCLKP	I	Positive LVDS differential data input (clock)
16	GND	G	Power Ground
17	RXIN3N	I	Negative LVDS differential data input (3)
18	RXIN3P	I	Positive LVDS differential data input (3)
19	GND	G	Power Ground
20	NC	--	No contact (For AUO internal use)
21	NC	--	No contact (For AUO internal use)
22	NC	--	No contact (For AUO internal use)
23	GND	G	Power Ground
24	GND	G	Power Ground
25	GND	G	Power Ground
26	VDD	P	+5V power supply
27	VDD	P	+5V power supply
28	VDD	P	+5V power supply
29	VDD	P	+5V power supply
30	VDD	P	+5V power supply

Note1: Start from left side

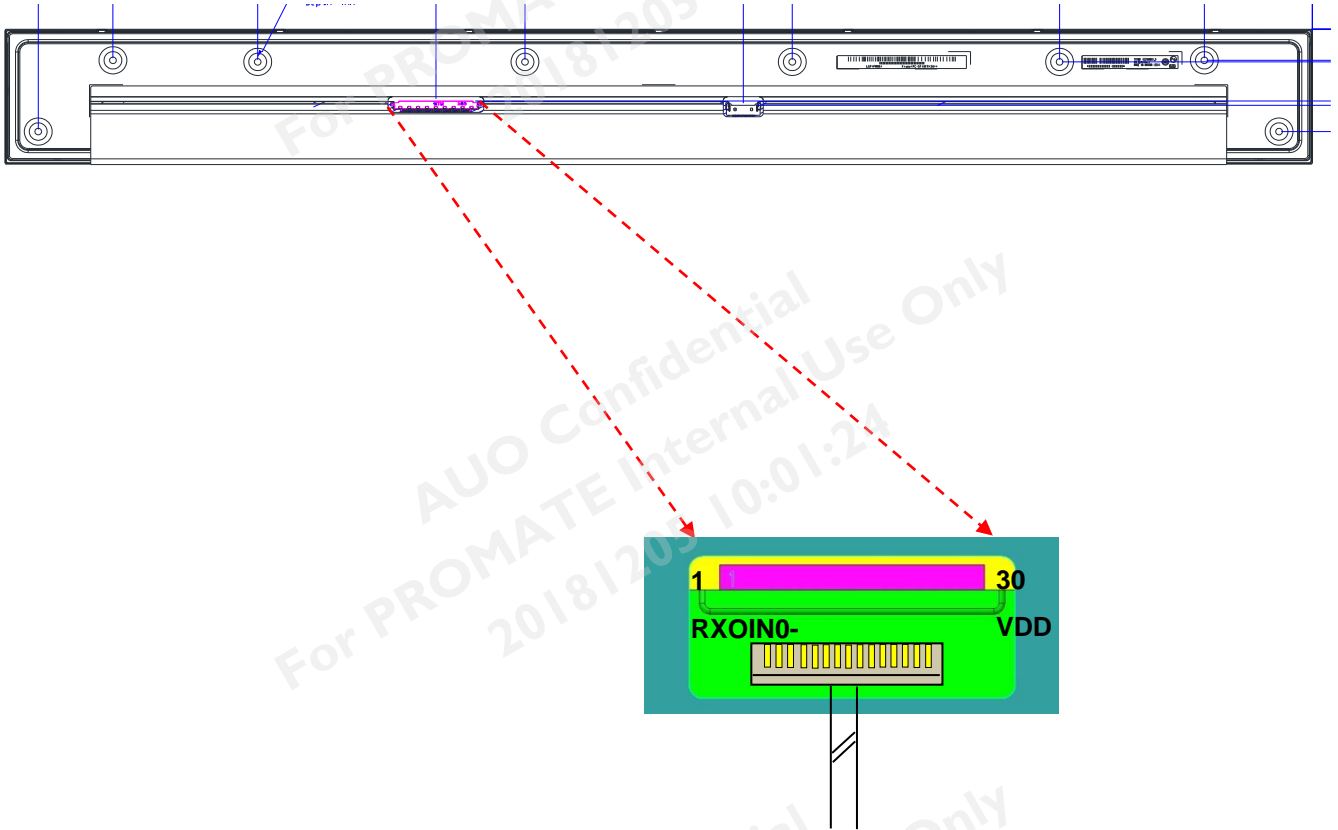

Note2: Input signals of clock shall be the same timing.

Note3: Please follow TV VESA Pin Assignment.

6.4 Timing Characteristics

Parameter	Symbol	Min.	Typ.	Max.	Unit	
Frame Rate	-	-	60	-	Hz	
Clock frequency	$1/T_{\text{Clock}}$	-	40	-	MHz	
Vertical Section	Period	T_V	-	195	-	T_{Line}
	Active	T_{VD}	165			
	Blanking	T_{VB}	-	30	-	
Horizontal Section	Period	T_H	-	3420	-	T_{Clock}
	Active	T_{HD}	1920			
	Blanking	T_{HB}	-	1500	-	

Note 1: Only DE mode operation.

6.5 Timing diagram

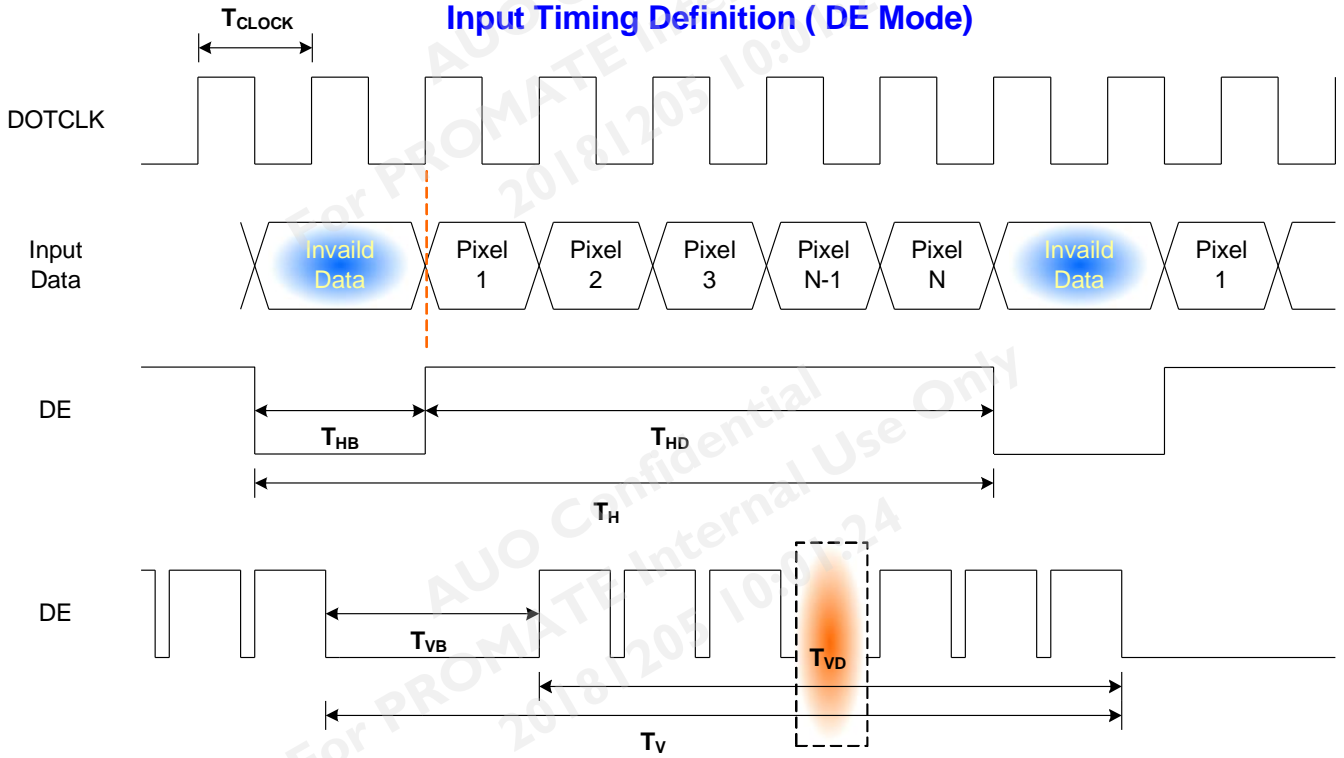

6.6 Power ON/OFF Sequence

VDD power and LED on/off sequence are as follows. Interface signals are also shown in the chart. Signals from any system shall be Hi-Z state or low level when VDD is off.

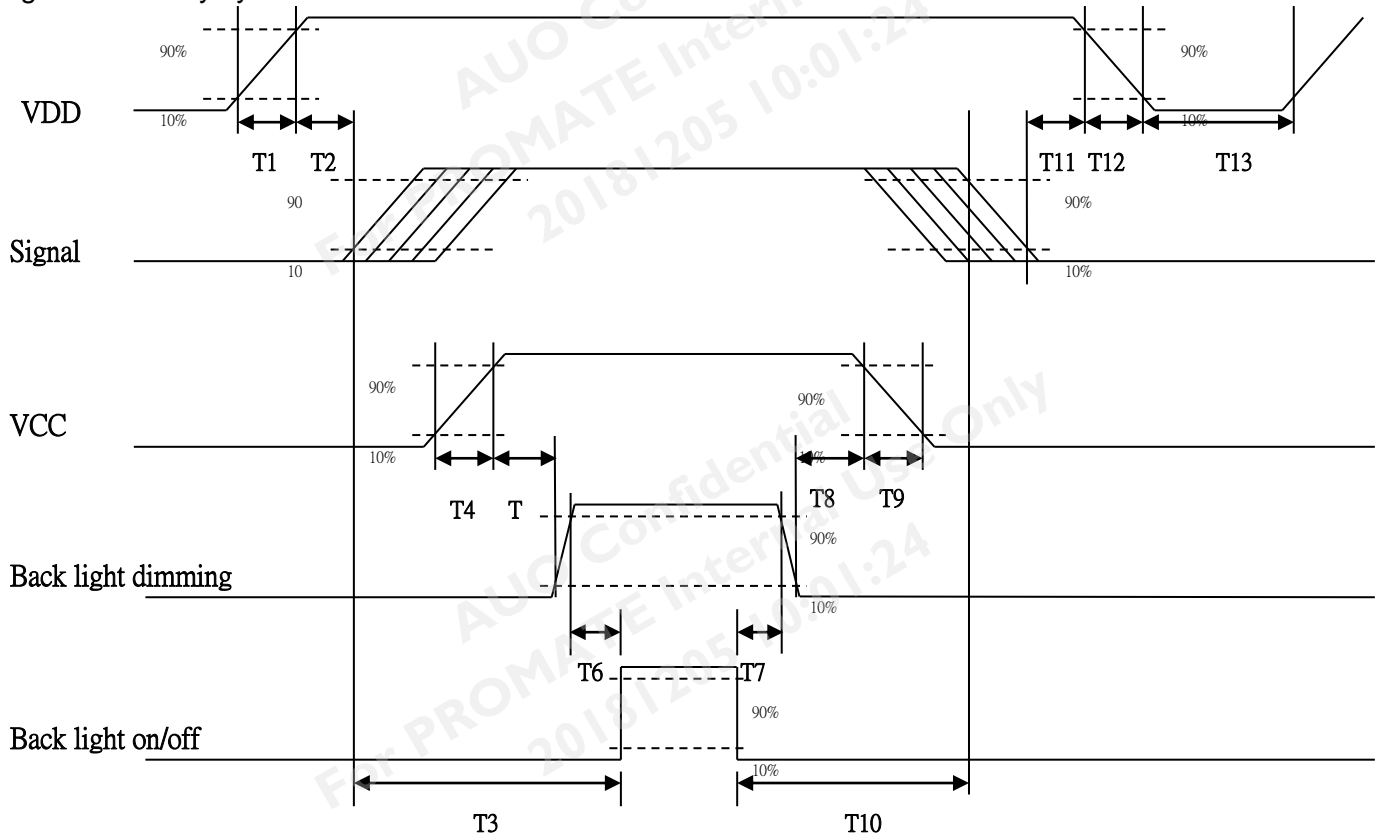

Power ON/OFF sequence timing

Parameter	Value			Units
	Min.	Typ.	Max.	
T1	0.5	-	10	[ms]
T2	30	40	50	[ms]
T3	200	-	-	[ms]
T4	0.5	-	10	[ms]
T5	10	-	-	[ms]
T6	10	-	-	[ms]
T7	0	-	-	[ms]
T8	10	-	-	[ms]
T9	-	-	10	[ms]
T10	110	-	-	[ms]
T11	0.5	16	50	[ms]
T12	-	-	100	[ms]
T13	1000	-	-	[ms]

7.0 Connector & Pin Assignment

Physical interface is described as for the connector on module. These connectors are capable of accommodating the following signals and will be following components.

7.1 TFT LCD Module

Connector Name / Designation	Interface Connector / Interface card
Manufacturer	SIN SHEN TERMINAL & MACHINE INC.
Type Part Number	MSBKT2407P30HB
Mating Housing Part Number	FI-X30C2EL or compatible

7.1.1 Pin Assignment

Pin#	Signal Name	Pin#	Signal Name
1	NC	2	NC
3	NC	4	GND
5	RXIN0N	6	RXIN0P
7	GND	8	RXIN1N
9	RXIN1P	10	GND
11	RXIN2N	12	RXIN2P
13	GND	14	RXINCLKN
15	RXINCLKP	16	GND
17	RXIN3N	18	RXIN3P
19	GND	20	NC
21	NC	22	NC
23	GND	24	GND
25	GND	26	VDD
27	VDD	28	VDD
29	VDD	30	VDD

7.2 LED Backlight Unit: LED Driver Connector

Connector Name / Designation	LED Connector
Manufacturer	ENTERY INDUSTRIAY CO.
Connector Model Number	3808K-F08N-12R
Mating Connector Model Number	MOLEX 51146-0800 or compatible



7.3 LED Driver Connector Pin Assignment

Pin#	Symbol	Signal Name
1	GND	GND
2	GND	GND
3	GND	GND
4	Enable	5V-On / 0V-Off
5	Dimming	PWM Dimming
6	VCC	12V
7	VCC	12V
8	VCC	12V

8.0 Reliability Test

Environment test conditions are listed as following table.

Items	Required Condition	Note
Temperature Humidity Bias (THB)	Ta= 50°C, 80%RH, 300hours	
High Temperature Operation (HTO)	Ta= 50°C, 300hours	3
Low Temperature Operation (LTO)	Ta= 0°C, 300hours	
High Temperature Storage (HTS)	Ta= 60°C, 300hours	
Low Temperature Storage (LTS)	Ta= -20°C, 300hours	
Vibration Test (Non-operation)	Acceleration: 1.5 G Wave: Random Frequency: 10 - 200 Hz Sweep: 30 Minutes each Axis (X, Y, Z)	
Shock Test (Non-operation)	Acceleration: 50 G Wave: Half-sine Active Time: 20 ms Direction: ±X, ±Y, ±Z (one time for each Axis)	
Drop Test	Height: 60 cm, package test	
Thermal Shock Test (TST)	-20°C /30min, 60°C /30min, 100 cycles	1
On/Off Test	On/10sec, Off/10sec, 30,000 cycles	
ESD (Electro Static Discharge)	Contact Discharge: ± 8KV, 150pF(330Ω) 1sec, 8 points, 25 times/ point.	2
	Air Discharge: ± 15KV, 150pF(330Ω) 1sec 8 points, 25 times/ point.	
Altitude Test	Operation:10,000 ft Non-Operation:30,000 ft	

Note 1: The TFT-LCD module will not sustain damage after being subjected to 100 cycles of rapid temperature change. A cycle of rapid temperature change consists of varying the temperature from -20°C to 60°C, and back again. Power is not applied during the test. After temperature cycling, the unit is placed in normal room ambient for at least 4 hours before power on.

Note 2: According to EN61000-4-2 , ESD class B: Some performance degradation allowed. No data lost. Self-recoverable. No hardware failures.

Note 3: No function occurs Mura shall be ignored after high temperature reliability test.

9.0 Shipping Label & Packaging

9.1 Shipping Label

The label is on the panel as shown below:

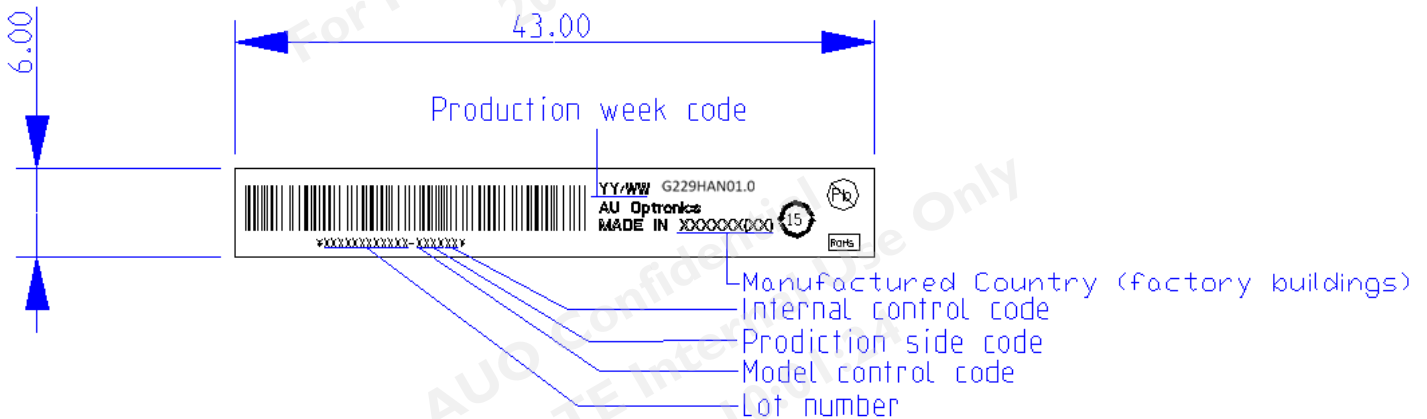

Unit: mm

Note 1: For Pb Free products, AUO will add  for identification.

Note 2: For RoHS compatible products, AUO will add  for identification.

Note 3: For China RoHS compatible products, AUO will add  for identification.

Note 4: The Green Mark will be presented only when the green documents have been ready by AUO Internal Green Team.

9.2 Packaging



1. Put out PP Board Tray placed on PP Board



2. Put 1pcs Panel into Tray CF upwards in Tray

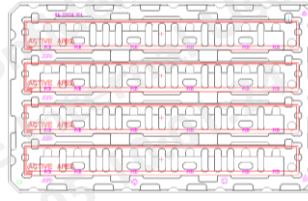

3. 1pcs Tray contained 4pcs Panel

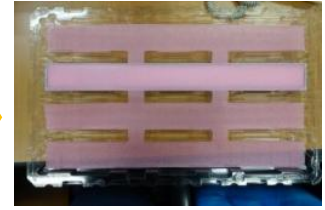

4. Finally put 1pcs spacer on first Panel.

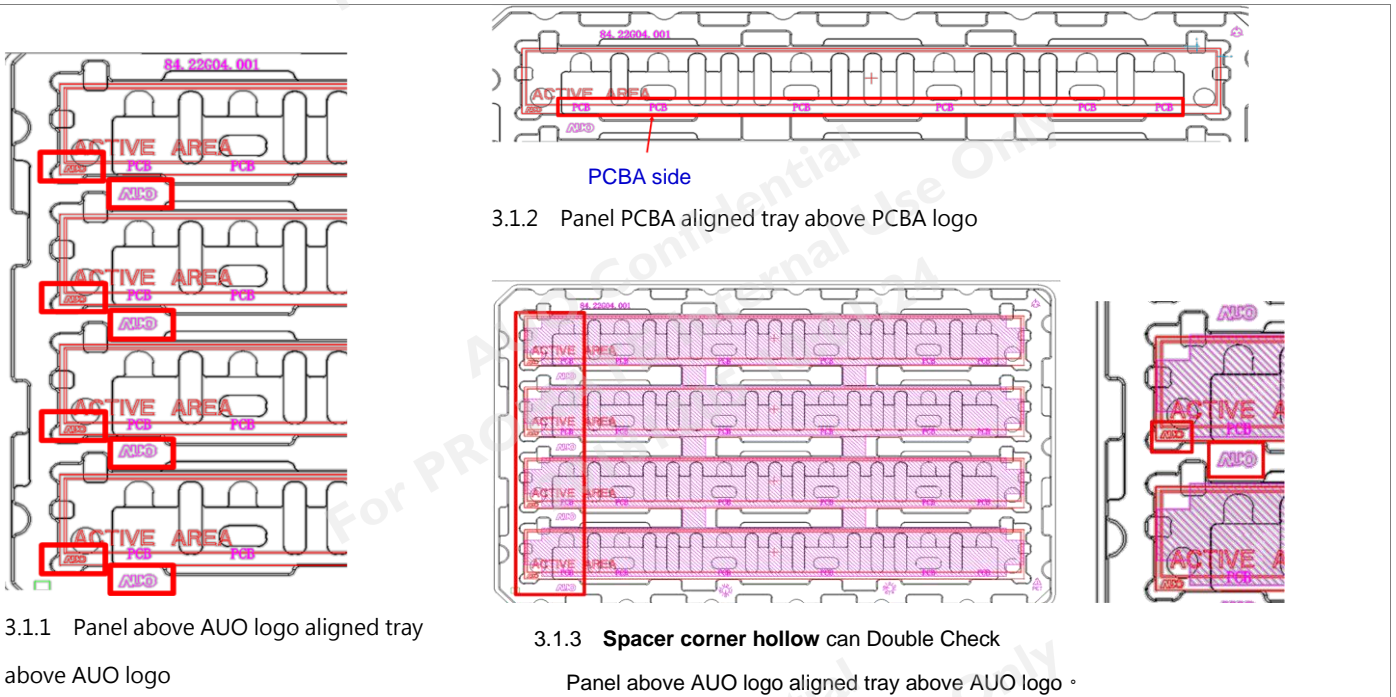

8. Stack 8layers PET tray as the method mention above (7tray+1dummy tray)



9. Insert the package from the sideways of the Antistatic Bag. Pack the bag, and then tape with scotch tape.



10. Placing EPE into carton



11. Placing trays into



12. Cover with EPE cushion



13. Sealing the carton with packing tape

Max capacity : 28 TFT-LCD module per carton

Max weight: 22.5 kg per carton

Outside dimension of carton: 730mm(L)* 480mm(W)*280mm(H)

Pallet size : 980 mm *740 mm * 132mm

Box stacked

Module by air: (1 *2) *4 layers, one pallet put 8 boxes, total 224 pcs module

Module by sea: One pallet (1 *2) *4 layers + One pallet (1 *2) *2ayers, total 336 pcs module

Module by sea_ HQ :(1 *2) *4 layers + One pallet (1 *2) *3 layers Total 392 pcs module

9.3 Shipping Package of Palletizing Sequence

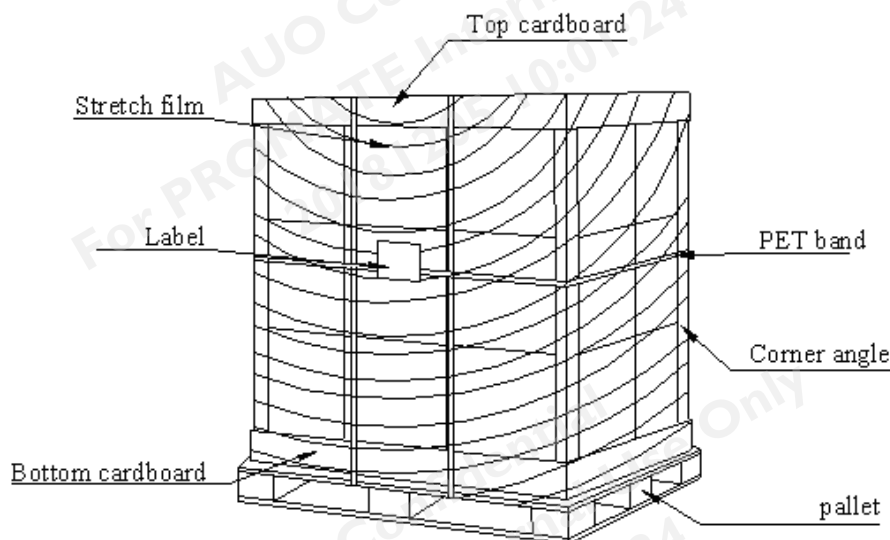

11 Safety

11.1 Sharp Edge Requirements

There will be no sharp edges or comers on the display assembly that could cause injury.

11.2 Materials

11.2.1 Toxicity

There will be no carcinogenic materials used anywhere in the display module. If toxic materials are used, they will be reviewed and approved by the responsible AUO toxicologist.

11.2.2 Flammability

All components including electrical components that do not meet the flammability grade UL94-V1 in the module will complete the flammability rating exception approval process.

The printed circuit board will be made from material rated 94-V1 or better. The actual UL flammability rating will be printed on the printed circuit board.

11.3 Capacitors

If any polarized capacitors are used in the display assembly, provisions will be made to keep them from being inserted backwards.

11.4 National Test Lab Requirement

The display module will satisfy all requirements for compliance to:

UL 60950-1, Second Edition

U.S.A. Information Technology Equipment